

CPC30413 - Cert III & CPC41013 Cert IV in Demolition

Student Reference Guide



This Reference Guide belongs to: _____

Author: Paul Douglas

Works Cited

Australian Bureau of Statistics. 4602.0.55.006 Waste Account, Australia, 2010-11. 1 May 2014. 13 July 2016

<<http://www.abs.gov.au/ausstats/abs@.nsf/Lookup/4602.0.55.006Main+Features32010-11>>.

Brisbane City Council. Dedicated to a better Brisbane. 01 Jan 2014. 14 July 2016

<<https://pdonline.brisbane.qld.gov.au/masterplan/default.aspx>>.

Commonwealth of Australia. "Department of the Environment." 8 July 2014. Business and industry portal. 14 July 2016 <<https://www.business.qld.gov.au/industry/csg-Ing-industry/water-environmental-management-csg/environmental-management-guidelines>>.

—. Work Health and Safety Regulation 2011. Vol. 240. Canberra: Commonwealth of Australia, 2011.

Philip Crowther (Qld University of Technology). "https://www.qut.edu.au/." 18-19 May 2000. Queensland University of Technology. 13 July 2016

<<http://eprints.qut.edu.au/2883/1/Crowther-TG39-2000.PDF>>.

Queensland Government. Asbestos - Clearance Inspections. 16 Feb 2016. 18 July 2016

<<http://www.deir.qld.gov.au/asbestos/removal/clearance-inspections.htm>>.

Safe Work Australia. Managing Risk of Plant in the Workplace Code of Practice. Canberra: Commonwealth of Australia, 2009.

—. Safe Work Australia. 01 January 2014. 13 July 2016

<<http://www.safeworkaustralia.gov.au/sites/SWA>>.

Work Safe. Work Safe Victoria. 1 September 2014. 15 July 2016

<<http://www.worksafe.vic.gov.au/plant-hazard-checklist>>.

Workplace health and safety Electrical Safety Office Worker's Compensation Regulator.

Asbestos and demolition notifications. 2 December 2015. 15 July 2016

<<https://www.worksafe.qld.gov.au/injury-prevention-safety/asbestos/asbestos-demolition-notifications#demolition>>.

Worksafe ACT. Incident investigation. 25 Jan 2016. 18 July 2016

<<http://www.worksafe.act.gov.au/page/view/1475>>.

Australian Standards

Note about Documents used in this Manual:

The forms provided within this document are samples only,

- Some of the forms may not be referenced in your training materials
- All forms are provided in the interest of achieving Best Practice in your business.
- Do not generally contain all of the requirements to achieve compliance
- Must have your Company details on them.
- Provided for training purposes only.

The latest version of documents used are available on our website. Once your training is complete you will need to subscribe to our web-site to maintain continuous access to the forms.

The following are available in our subscription service :

- **Procedures**
- **Safe Operating procedures**
- **Safe work Method Statement templates**
- **Risk Assessments**
- **Forms (fillable)**
- **Training videos**

(Refer to Appendix for a complete list)

If you wish to obtain these forms or an Integrated Management System for use in your business,

please contact the author <https://achievebestpractice.com.au/>

Preface

This Reference Guide and Workbook has been developed by Paul Douglas, to support the delivery of Certificate III & IV Demolition qualifications.

The information presented within this document is intended to provide educational reference information for students intending to become Supervisors in the construction industry within Australia. The copyright owner accepts no responsibility for the completeness or accuracy of any of the information contained in or accessed through this document. Although every effort is made to ensure the currency of information, users should research the latest information and make their own judgments about matters relating to their own businesses and/or seek independent advice.

Subject to the acknowledgements, this work is copyright. Apart from any use as permitted under the Copyright Act 1968, no part may be reproduced by any process without prior written permission from Paul Douglas. No part of this work may be reproduced or transmitted in any form or by any means, electronic or mechanical, including photocopying, scanning, recording or any information storage and retrieval system, by individuals or organizations that have not purchased the work, nor by making copies for hire or resale to third parties.

This learning process differs from the normal training systems. The usual method of delivery requires delivery of materials in a set format which often repeats information and segregates the information in a way that may be confusing.

For those with industry experience who are wishing to formalise their industry skills to be formally recognised, this document provides a summary of not only the information contained in the various units of competency but also provides a reference guide in a step by step process from beginning to end of the job.

The process used is called "Clustering", this has often been undertaken with assessment but not training delivery.

In the Appendices there are not only sample forms but also some task specific training information, guidelines on establishing Best Practice in a business and other useful reference materials

Exclusions

This guide may not include all documentation such as

Integrated Management Systems (IMS)

Policy & Procedures Manual (P&P)

Safe Operating Procedures (SOP)

Safe Work Method Statements(SWMS)

These are available from the Author by subscription www.AchieveBestPractice.com.au

Printing out this book

Please do not print the book, consider the environment!

More importantly the hyperlinks do not work in a printed version!

Contents

Works Cited	2
Note about Documents used in this Manual:.....	3
Preface.....	4
Exclusions	4
Printing out this book.....	4
Introduction.....	18
Demolition licencing.....	18
<i>Training required for Licencing</i>	18
Safety.....	18
<i>Video - Work safe for the moments that matter</i>	18
<i>Video - Safety culture and climate in transport webinar</i>	18
<i>Video - Introduction to ergonomics in the workplace</i>	18
Environment.....	18
Legislative Framework	19
<i>Other Legislation also applies</i>	20
Chapter 1 - Assess site and scope of work	21
Describe the construction process for a project.....	21
Client Project Needs.....	22
Ownership.....	22
Assess site and scope of work.....	23
Create contractual documentation and QA processes.....	23
<i>Plans & Specifications</i>	23
<i>Requirements of site plan determined</i>	23
<i>Site inspection is conducted</i>	23
<i>Development application</i>	24
<i>Building permit application</i>	24
<i>Plumbing permit</i>	24
<i>Notification to Safety Authority</i>	24
<i>Insurance</i>	24
<i>Connect the town water</i>	25
<i>Connect electricity</i>	25
<i>Work Schedule (GANTT chart or MS Project)</i>	25
<i>Gantt chart - Wikipedia</i>	25
<i>Contracts for Residential work</i>	25
<i>Requesting information</i>	25
Estimating the cost of the project.....	25
<i>Quick estimates</i>	25
<i>Supplier quotes</i>	25
<i>Bill of Quantities</i>	25
<i>Quotation</i>	26
<i>What might not be included in a quote to build a project?</i>	27
Chapter 2 - Planning and preparing for work.....	28
Prepare a Project Management Plan (PMP)	28
<i>Video - Understanding Hazards and Risks</i>	28
Schedule activities.....	28
Prepare safe work method statements for individual activities.....	29
Arrange resources for activities.....	29
Conduct site induction and team briefing for the project.....	29
<i>Video - Involving workers to develop solutions for hazardous manual tasks</i>	29
Determining the training needs of workers.....	30
Assess potential impacts of tasks.....	30
Identify measures to minimise impacts of work on the environment.....	30
Identify measures to minimise impacts of work on the public.....	30

Brief team and supervise implementation of impact minimisation strategies.	31
<i>Video - Reducing the risk of manual tasks injuries in the workplace</i>	31
Supervise preparation for work.	31
<i>Video - A Back Injury Can Change Your Life</i>	31
<i>Video - Lifting in the Workplace</i>	31
Establish a folder for each project	31
<i>Documentation set-up checklist</i>	31
<i>Ensure documentation for each new project is established</i>	31
<i>Drawings issued</i>	31
<i>Request for information</i>	32
<i>Site diary</i>	32
<i>Condition / Dilapidation reports</i>	32
Create supplier contracts or purchase orders	32
<i>Subcontract Agreement</i>	32
<i>Contract of supply</i>	32
<i>Purchase orders</i>	32
Chapter 3 -Identify and Assess Risk.....	34
Taking care of safety	34
Hazard Identification.....	35
<i>Video - Introduction to ergonomics in the workplace</i>	35
<i>Video - Slips, Trips, and Falls</i>	35
<i>Video - Remote and isolated work</i>	35
<i>WH&S Management Plan (WHSMP)</i>	35
<i>Traffic management</i>	35
<i>Video - Worksite Dangers for Traffic Control Persons</i>	35
Apply Safe Work Practices	37
<i>Identify High-Risk tasks</i>	37
<i>Young workers</i>	37
<i>Video - Young and New Worker Programs</i>	37
<i>Work at heights</i>	37
<i>Refer to Training materials - Appendix 2 Work at heights</i>	37
<i>Use of Plant</i>	37
<i>Use of Hazardous chemicals</i>	37
<i>Refer to chapter "Identify Hazardous materials"</i>	37
<i>Excavation</i>	37
<i>Work over water</i>	37
<i>Refer to Training materials - Appendix 2 Hazard Identification</i>	37
<i>Work near live electrical</i>	37
<i>Confined space entry</i>	38
<i>Inductions / Toolbox talks</i>	39
<i>SWMS</i>	39
Safe operating procedures.....	40
<i>Equipment inspections</i>	41
<i>Site hazard inspections</i>	41
<i>Daily pre-start checklist</i>	41
Drugs and Alcohol	41
<i>Video - A Deadly Silence: Substance Abuse and Accidents</i>	41
Chapter 4 – Identify Hazardous Materials.....	42
Hazardous chemicals.....	42
<i>Video - Hazchem - Hazardous Substances</i>	42
<i>Video - Hazchem - SDS</i>	42
<i>Video - Chemical security for employees</i>	42
<i>Video - Shipping Container Explodes, Injuring Worker</i>	42
<i>Video - Chemical security for small business owners and managers</i>	42

<i>Hazardous chemicals Register</i>	42
<i>Video - Pesticide Storage</i>	42
Silica	42
<i>Video - Silica Exposure</i>	42
Asbestos removal clearance certificate	42
<i>Video - Asbestos Hazards in Renovations, Restorations, and Demolition</i>	43
Chapter 5 – Protect the Environment	44
Environment Management Plan	44
Identify measures to minimise impacts of work on the environment.....	44
Environmental considerations meeting (Harmonisation).....	44
Environmental permit	45
Manage recyclables & waste	45
Chapter 6 – Emergency Management.....	46
Emergency Management Plan	46
<i>Video - Expect the Unexpected: Emergency Preparedness</i>	46
Incident investigation.....	47
Meeting – Incident investigation (research).....	49
Return to work	49
Chapter 7 – Site Operations	50
Plant operations	50
<i>Video - Compactor Rollover Injures Operator</i>	50
Small plant is operated according to manufacturer specifications	50
<i>Video - Angle Grinders</i>	50
<i>Video - Circular Saw Guarding</i>	50
<i>Video - Circular Saw Kickback</i>	50
<i>Video - Safe Handling of Nail Guns</i>	50
<i>Video - Nail Gun Safety</i>	50
<i>Video - Guarding for Woodworking</i>	50
Communication is maintained with team members.....	50
Work site conditions and progress are monitored in consultation with team.....	50
Video – Supervisors - conduct a meeting.....	50
SWMS to be reviewed.....	50
Materials and building component parts are safely handled	51
Materials and components identified for salvaging are dealt with	51
Site is protected and secured to prevent unauthorised access.....	51
Monitor and manage tasks and procedures	51
Permits to Work	51
Hot Work.....	51
Work safely at heights.....	51
VOC Selection and use of equipment and PPE.....	51
Variation advice.....	51
End of day checklist.....	51
Housekeeping.....	52
<i>Removal of debris</i>	52
<i>Dusting</i>	52
<i>Removal of dirt</i>	52
<i>Chemicals</i>	53
<i>Tools</i>	54
<i>Yard</i>	54
Chapter 8- Finalising the project	55
Finalise activities	55
<i>Plan handover of property.</i>	55
<i>Monitor quality and timeliness of job completion.</i>	55
<i>Conduct handover site inspection with stakeholders.</i>	56

<i>Supervise site clean-up</i>	56
<i>Finalise work and complete handover documentation</i>	56
<i>Handover checklist (Practical Completion)</i>	56
<i>Meeting – Closing the project</i>	57
<i>Meeting – Evaluation</i>	57
Appendix 1. – Establishing your business.....	59
Where can I get help?	59
Research.....	59
Business Plan.....	60
Policy & Procedures Manual.....	60
Compliance.....	60
<i>Integrated management systems</i>	60
Resourcing of the Management Systems	61
<i>Company manuals and documents</i>	61
<i>Bullying and Harassment</i>	61
<i>Quality Assurance</i>	61
<i>Quality Assurance tutorials</i>	61
Implementation of system	62
<i>Establish a folder for each project</i>	63
<i>Contractor Management</i>	64
Resources for Builders.....	64
Audit.....	65
<i>Audit Preparation</i>	65
Meeting – Site safety audit	65
<i>Video - The Safety Inspection Process</i>	65
Work improvement notice.....	66
Meeting – Review the non-conformance from the audit	66
<i>Protecting yourself from Safe Work Liability</i>	66
<i>What do I need in a Safety Management System?</i>	67
<i>Training :- Times, “They are a changin”</i>	67
Appendix 2. - Learner materials	69
Read and Interpret Plans and Job Specifications	69
Basic Calculations.....	69
<i>Area</i>	69
<i>Volume</i>	69
<i>Grade</i>	69
Plans, Drawings and Sketches	71
Types of Plans.....	71
Key Functions of Drawings	72
Common conventions may include:.....	72
Aspect in Drawings.....	73
Features of Plans and Elevations	73
Key Features of Plans	73
<i>Symbols and Abbreviations</i>	73
<i>Notes</i>	74
<i>Legend</i>	74
<i>Scale</i>	74
<i>Title Panel</i>	74
Checking Plans for Amendments	74
<i>Amendments to plans and specifications can include changes to:</i>	75
<i>Other related factors.</i>	75
<i>Amendment Registers / Drawing Register</i>	75
<i>Identify Key Features of the Site</i>	75
<i>Datum</i>	75

<i>Type of Product or Service</i>	76
<i>Quantities</i>	76
<i>Characteristics of the Site</i>	76
<i>Logistics in conjunction with the site features</i>	76
<i>Services and Utilities</i>	77
<i>Orientation of the Plan with the Site</i>	77
<i>Materials and quality of work</i>	77
Identify Standards of Work, Finishes and Tolerances.....	78
<i>Standards of Work</i>	78
<i>Australian Standards</i>	78
<i>Finishes</i>	78
<i>Tolerances</i>	79
<i>Material attributes detailed in the job specifications will include:</i>	79
Hazard Identification	80
Identify sources of information.....	80
Obtain information to determine workplace risks and risk controls	80
<i>Collect information</i>	80
<i>Record your findings</i>	81
Contribute to compliance and workplace requirements	81
<i>Harm the hazard can cause</i>	82
Identify duty holders and their range of duties	83
<i>Worker duties</i>	83
Contribute to workplace hazard identification	84
Apply knowledge.....	85
<i>Under the WHS Act:</i>	85
<i>Apply techniques, tools and processes</i>	86
<i>The benefits of assessing and managing risks</i>	86
Tools and equipment	91
<i>Selecting risk assessment techniques, tools and processes</i>	91
<i>Document method and outcomes of risk assessment</i>	92
<i>Small plant and equipment are identified and checked for serviceability</i>	93
Hired Plant & equipment	93
<i>Methods of operation of small plant and equipment are identified</i>	93
<i>WHS Requirements for the selected small plant and equipment are identified</i>	94
<i>Confirmation is obtained that existing services have been disconnected.</i>	94
<i>Work site inspection is conducted, and hazards associated are assessed</i>	94
<i>Safe work method is amended</i>	94
<i>Work area is prepared</i>	95
<i>Small plant and equipment are selected.</i>	96
<i>Pre-Operational Checks are completed</i>	96
<i>Small plant and equipment are used for their intended purpose</i>	96
<i>Small plant and equipment are cleaned, checked, maintained</i>	96
Permits to Work	97
Permit Control Systems.....	97
Permit Requirements	97
Monitor Variables	97
Confirm the Need for a Work Permit.....	98
Types of Work Permit.....	98
Identify the Correct Permit	98
Check Permit Documentation	98
Permit Details.....	99
Validity Period	99
Validate the Permit	99
Authorising the Permit.....	99

Consultation with Permit Workers.....	100
Carry Out Regular Inspections.....	100
Review the Permit.....	101
Check Job Status and Closing the Permit	101
Hot Work	102
Plan & prepare	102
<i>Hot Work Hazards Include:</i>	102
<i>Hot Work Permits</i>	102
<i>Form sample – Permit to work</i>	102
<i>Hot Work Restrictions</i>	102
Select tools.....	102
<i>Personal Protective Equipment</i>	102
Complete cutting, grinding hot work.....	103
<i>Video - Hot work and welding near explosive substances</i>	103
<i>Disconnection of services</i>	103
<i>Form sample – Permit to work</i>	103
<i>Potential explosions</i>	103
Clean-up	103
Work safely at heights.....	104
Identify work area requirements.....	104
Access work area.....	104
<i>Fall protection equipment where required is correctly fitted, adjusted and anchored</i>	104
<i>Fall Protection</i>	104
<i>Fall Protection a light hearted approach</i>	104
<i>Fall Protection Can Save Your Life</i>	104
<i>Ladder Safety 1 Introduction</i>	104
<i>Ladder Safety 2 Choosing the Right Ladder</i>	104
<i>Ladder Safety 3 Job Constructed Ladders</i>	104
<i>Ladder Safety 4 Ladder Setup</i>	104
<i>Ladder Safety 5 Safe Use</i>	104
<i>Falls from Ladders</i>	104
<i>Ladder Safety: Stepladders</i>	104
<i>Ladder Safety: Extension Ladders</i>	104
<i>Ladder Safety: Ladders on Scaffolds</i>	104
<i>Form sample – Permit to work</i>	104
<i>Arrangements are made to appropriately install required equipment taking account of all potential hazards</i>	104
<i>Video - Falls through Openings</i>	104
<i>Video - Worker Falls Down Vent Shaft</i>	104
<i>Video - Instructions to assemble mobile scaffold</i>	104
<i>Video - Scaffolding for beginners by Kennards Hire</i>	104
<i>Appropriate methods are used to access work area for self, tools and equipment, and materials.</i>	104
<i>Video - Using elevating work platforms safely</i>	105
<i>Video - Safely loading and unloading elevating work platforms</i>	105
<i>Video - Standing on the Edge</i>	105
<i>Tools and materials are placed to eliminate or at least minimise the risk of items being knocked down.</i>	105
Conduct work tasks.....	106
<i>Work is conducted following workplace approved procedures</i>	106
<i>Fall protection equipment is kept in place and adjusted appropriately to cater for movement during work.</i>	106
<i>Video - Scaffold Safety</i>	106
<i>Scaffold components and fall barriers are kept in place during work.</i>	106

<i>Egress from work area is completed following work site supervisor approved methods for self, tools, materials and environmental requirements.</i>	107
Work In Confined Spaces.....	108
Definitions	108
<i>Form sample – Permit to work</i>	110
Design, Manufacture, Supply And Modification	110
Plan and prepare for working in confined space	110
<i>Access, interpret and apply procedures for confined space entry and the environmental management plan and ensure the work activity is compliant</i>	110
<i>Obtain, confirm, clarify and apply work instructions and agreed procedure</i>	110
<i>Obtain, confirm, clarify and apply safety requirements</i>	110
<i>Obtain and confirm authorisation (entry permit) meets regulatory requirements</i>	111
<i>Confirm the emergency response procedure is with the stand-by person and understood</i>	111
<i>Identify, obtain and implement signage and barrier requirements</i>	112
<i>Select tools and equipment for the tasks, check for serviceability and rectify or report any faults</i>	112
<i>Identify, confirm and apply the environmental protection requirements</i>	113
<i>Position rescue equipment by the entry permit</i>	113
Performing work in confined space	113
<i>Gain access to confined space</i>	113
<i>Correctly apply tagging and lock-out procedures</i>	113
<i>Video - Lockout: A Guide to Safe Work Practices</i>	113
<i>Video - Electrical Safety: Underground Contact</i>	113
<i>Enter the confined space correctly</i>	113
<i>Maintain ongoing communication with the stand-by person</i>	113
<i>Comply with entry permit requirements</i>	113
<i>Monitor and adhere to allocated entry time</i>	113
Exit confined space.....	113
<i>Exit confined space correctly</i>	113
<i>Recover tools, equipment and materials</i>	114
<i>Conduct inspection of the confined space</i>	114
<i>Secure access to the confined space</i>	114
<i>Remove tagging and lock-out</i>	114
<i>Accurately complete confined space entry permit</i>	114
Clean up.....	114
General Plant operations.....	115
Plan and prepare	115
<i>Competent Operators</i>	115
<i>Registrable Plant</i>	115
<i>High Risk Work</i>	115
<i>Design Standards</i>	115
<i>Control Devices</i>	115
<i>Noise Levels</i>	115
<i>Video - The Hearing Video</i>	115
<i>Terminology</i>	115
<i>What is fatigue?</i>	116
<i>Effects of fatigue</i>	116
<i>Potential Hazards And Control Measures</i>	117
<i>Follow Traffic Management Plans</i>	117
Conduct machine preoperational checks.....	118
<i>Guarding/Failsafe Devices</i>	118
<i>Operator Protection Bars (ROPS/ FOPS)</i>	118
<i>Safety bars, props and pins</i>	118
<i>Operator responsibilities</i>	118
<i>Video - Mobile Crane Failures: Why Maintenance and Inspections Are Critical</i>	118

Fire-fighting procedures.....	119
<i>Fire suppression systems</i>	119
<i>Fire suppression system operation</i>	120
<i>Out of service tags</i>	120
<i>Personal danger tags</i>	120
<i>Warning plates and labels</i>	121
<i>Burn prevention</i>	121
Operate machine.....	121
<i>For operational instructions refer to separate machine guidelines</i>	121
<i>Video - Mobile Equipment</i>	121
<i>Check Ground Conditions</i>	121
<i>Working Near Overhead Powerlines Including Service Lines</i>	121
<i>Video - A Guide to Power Line Safety</i>	121
<i>Using A Safety Observer</i>	121
<i>Engineering Principles - Centre of Gravity (CG)</i>	122
<i>Exclusion Zones</i>	122
<i>Video – Plant - barricades and exclusion zones</i>	122
<i>Blind spots</i>	122
<i>Vision impairments:</i>	123
<i>Access on and off the machine</i>	123
<i>Horn signals</i>	123
<i>Guarding</i>	124
<i>Passengers</i>	124
<i>Restricted area</i>	124
<i>Cause of Trench Collapse</i>	124
<i>Video - Excavations: a Guide to Safe Work Practices</i>	124
<i>Back Filling Trenches</i>	124
<i>Video - Excavation Death Trap</i>	125
<i>Smooth Controls And People Safety</i>	125
<i>Excavating And Levelling The Site</i>	125
<i>Video - Underground Utilities</i>	125
<i>Video - Electrical Safety: Underground Contact</i>	126
<i>Cut And Fill</i>	126
<i>Video - Plant - Underground Utilities</i>	126
<i>Video – Plant - Utilities</i>	126
<i>Back blading</i>	126
<i>Precautions For Working On Inclines</i>	127
<i>Driving Up And Down Slopes</i>	127
<i>Lift, carry and place materials</i>	128
<i>Video - Plant - safely-lift-with-equipment</i>	128
<i>Night-time operating rules and tips</i>	128
<i>Techniques For Travelling With A Full Bucket</i>	128
<i>Public Roads</i>	128
<i>On Rough Terrain</i>	128
<i>Stockpiling</i>	128
<i>Techniques For Loading Trucks</i>	129
<i>Video - Working in and around mobile plant</i>	130
<i>Video - Safely securing loads of trucks</i>	130
<i>Video - Fly Rock from Blasting It was raining rocks!</i>	130
Select, remove and fit attachments.....	131
<i>Video - Plant - attachments</i>	132
<i>Different Attachments And Their Uses</i>	132
<i>Fitting And Removal Of Attachments</i>	132
<i>Relocate the machine</i>	132

<i>Video - Loading and unloading mobile plant</i>	132
<i>Video - Managing your drivers' safety at delivery points</i>	133
<i>Video - A Guide to Power Line Safety – Contact with a power line</i>	133
<i>Carry out machine operator maintenance</i>	133
<i>Clean up</i>	133
Operate Skid steer loader Guidelines.....	134
<i>Safe Operation of Plant</i>	134
<i>Skid steer Loader Characteristics</i>	134
<i>Controls For Skid Steer Loaders</i>	135
<i>Turning Controls</i>	135
<i>Bucket Controls</i>	136
<i>Foot Controls</i>	136
<i>Hand Controls</i>	137
<i>Loader Arm/Shovel Control Lever</i>	137
<i>Driver Protection Bar</i>	138
<i>Operator Techniques</i>	138
<i>To fill bucket from a stockpile:</i>	138
<i>To Dig Into Hard Ground</i>	138
<i>Levelling and Back Filling With Bucket</i>	138
<i>Excavating With the Front Bucket</i>	138
<i>Smooth Operation Of The Bucket</i>	139
Operate Excavator Guidelines.....	141
<i>Safe Operation of Plant</i>	141
<i>Video - Electrical exclusion zones</i>	141
<i>Track frame or undercarriage</i>	141
Superstructure.....	142
Boom, stick and bucket.....	143
Daily Procedures.....	143
Machine boarding and dismounting.....	143
Excavator Components.....	143
Electronic Monitoring System (EMS).....	143
Warning categories.....	143
<i>Level 1 – Operator awareness</i>	143
<i>Level 2 – Operator response</i>	144
<i>Level 3 – Immediate shutdown</i>	144
Key start switch.....	144
Ground level engine shutdown switch.....	144
Emergency stop button.....	144
Power mode switch.....	145
Engine throttle switch.....	145
Working switch.....	145
Swing lock pin.....	146
Hydraulic lock lever.....	146
Steering controls.....	146
Left travel lever / pedal operation.....	146
Right travel lever / pedal operation.....	147
Spot left turn.....	147
Spot right turn.....	147
Pivot left turn.....	147
Pivot right turn.....	147
Operating Techniques.....	148
Digging technique.....	148
<i>Loading techniques</i>	149
Straight loading.....	149

Tail loading	149
<i>Corner loading</i>	150
Top loading.....	150
Loading on a level surface.....	150
Tramming	150
Manoeuvring the excavator between the bench and pit floor.....	150
<i>Tramming off the bench</i>	151
<i>Tramming on to the bench</i>	151
Drop cuts	151
Cutting batters	151
Maximising productivity.....	152
Slew brake	152
Operate EWP Guidelines	153
<i>Video - Plant - Safely loading and unloading EWP</i>	153
<i>Safe Operation of Plant</i>	153
What Is An Elevating Work Platform?.....	153
Hand And Audible Signals	154
Position Elevated Work Platform For Work Application.....	155
<i>Eliminate The Risk Of Tools, Equipment And Materials Falling</i>	156
Fall Protection Requirements	156
Operate Elevated Work Platform.....	156
<i>Operating a scissor lift:</i>	157
<i>Operating a trailer mounted EWP:</i>	157
<i>Operating a vertical type EWP:</i>	157
<i>Operating a knuckle / boom EWP:</i>	157
Emergency Descent Devices (EDD)	158
Lower Elevated Work Platform And Shut Down	158
<i>Powerlines</i>	159
<i>Post-Operational Checks</i>	159
Mobile plant on suspended slabs.....	159
Instructions and advice from structural engineer regarding demolition techniques on suspended floors and load bearing capacities are followed.	159
Placement of mobile plant and allowable weight of demolition debris loads on suspended floors are confirmed according to advice of structural engineer.....	159
Mechanical equipment and plant are positioned in operating locations and appropriate exclusion zone and traffic control are arranged.....	159
Placement of mobile plant and allowable weight of demolition debris loads on suspended floors are monitored and controlled throughout the demolition process.	159
Mobile plant is moved safely between work locations, observing relevant codes and traffic management requirements.....	160
Mobile plant is operated on suspended floors to demolish building elements or remove demolition debris using suitable attachments according to approved demolition plan, structural engineering advice, and current safe work method.	160
Communication is maintained with team members, during the demolition process.	160
Regular programmed operator maintenance tasks are conducted according to manufacturer specifications and workplace requirements and log sheets are completed.	160
Operate Demolition crushing plant.....	161
Operating technique is selected and modified to meet changing work conditions according to workplace and environmental requirements and manufacturer recommendations.	161
Uncrushed materials are directed into hopper, and feed of uncrushed materials is maintained according to manufacturer instructions.	161
Operations are monitored, conducted and controlled within the equipment limitations and while communicating with relevant personnel, to maintain crushing and screening efficiency and effectiveness.	161

Crushing plant is stopped, cleared of blocked materials and restarted as required, according to manufacturer instructions and site safety plan.	162
Crushing plant settings are maintained according to manufacturer instructions.	162
Operate mobile plant on suspended floors.	162
Placement of mobile plant and allowable weight of demolition debris loads on suspended floors are monitored and controlled throughout the demolition process.	162
Mobile plant is operated on suspended floors to demolish building elements or remove demolition debris using suitable attachments according to approved demolition plan, structural engineering advice, and current safe work method.	162
Power line distances.	163
SA / TAS / NT / ACT (AS2550.1)	163
VIC	163
NSW	163
QLD	163
WA	164
<i>A Guide to Power Line Safety</i>	164
Manage recyclables & waste	165
Organise materials and equipment for loading.	165
Materials shall be segregated	165
Recyclable materials to be loaded	165
Waste materials to be loaded are identified and checked	165
Load and move materials.	165
Unload and store materials.	166
Explosive Powered Tools (EPT)	167
Plan & prepare	167
<i>Hazards</i>	167
<i>Personal Protective Equipment</i>	168
<i>Tool Types</i>	168
<i>Tool Components</i>	168
Set-out fasteners.	168
<i>Cartridges</i>	170
<i>Gas Canister</i>	171
Use EPT.	171
<i>Fastening Steel</i>	171
<i>Fastening Concrete and Masonry</i>	171
<i>Misfires</i>	172
Secure & store EPT	172
Maintain EPT	173
Storage	173
Clean up.	174
Lead Exposure	175
<i>Controlling Lead Exposure</i>	175
Cut and bend materials using oxy-LPG equipment.	176
<i>Plan and Prepare</i>	176
<i>Applications</i>	176
<i>Work instructions and operational details are obtained</i>	176
<i>Safety (OHS) requirements are followed</i>	176
<i>Protective Clothing</i>	176
<i>Hazards</i>	176
<i>Signage and barricade requirements are identified and implemented</i>	177
<i>Plant, tools and equipment are selected</i>	177
<i>Materials quantity requirements are calculated</i>	177
<i>Materials appropriate to the work application</i>	177
<i>Environmental requirements are identified</i>	177

Set up and Test Equipment	177
<i>Correct fire extinguisher is selected</i>	178
<i>Regulators are attached to oxy and acetylene bottles</i>	178
Mechanical Oxy Cutting Equipment.....	178
<i>Lines are purged to manufacturer recommendations prior to lighting up.</i>	179
<i>Equipment is tested for leaks</i>	179
<i>Correct pressures and cutting tips are selected</i>	179
Cutting Torches	179
<i>Cutting Nozzle</i>	179
Cut Material	180
<i>Material is accurately marked and secured or clamped ready for cutting.</i>	180
<i>Torch is lit correctly and safely according to manufacturer specifications.</i>	180
Cutting Flames and Adjustment.....	180
<i>Correct cutting position is adopted during cutting to set-out mark.</i>	181
Heat and Bend Material.....	181
<i>Material is accurately marked and securely clamped ready for cutting.</i>	181
<i>Torch is lit correctly and safely according to manufacturer specifications.</i>	182
<i>Trouble Shooting</i>	183
<i>Heat is applied and weakening effects of the heating process are minimised</i>	183
<i>Flame Cutting Theory and Practice</i>	184
Shut Down	184
<i>Torch is switched off according to manufacturer specifications.</i>	185
<i>Gas supply is shut off according to manufacturer specifications.</i>	185
Clean-up	185
Demolition.....	186
Demolition Licencing.....	186
Demolish Small Buildings.....	187
Requirements of site demolition plan determined.....	187
Site inspection is conducted	187
Confirmation is obtained that relevant services have been disconnected.....	187
Requirements for safe work at heights.....	188
Site is protected and secured to prevent unauthorised access.....	188
Building components are dismantled or demolished	188
Small plant is operated according to manufacturer specifications	188
Communication is maintained with team members.....	188
Work site conditions and progress are monitored in consultation with team.....	188
SWMS to be reviewed	189
Removed components are relocated to storage or disposal area.....	189
Materials and building component parts are safely handled	189
Materials and components identified for salvaging are dealt with	189
Work area is cleared, and materials disposed of	189
Plant, tools and equipment are cleaned, checked, maintained and stored	189
Asbestos Removal.....	190
Asbestos Types	190
<i>Chrysotile</i>	190
<i>Amosite</i>	190
<i>Crocidolite</i>	190
Uses And Applications.....	190
Health Hazards	190
<i>Asbestosis</i>	190
<i>Mesothelioma</i>	190
Personal Protective Equipment	191
<i>Face Mask</i>	191
<i>Protective Clothing</i>	192

Removal of Asbestos	192
<i>Signs And Barriers</i>	192
<i>Equipment For Asbestos Removal</i>	192
<i>Setting up the removal area</i>	193
<i>Removal Techniques</i>	193
<i>Removal of Asbestos Cement Products</i>	194
<i>Cleaning Up of Asbestos Cement Debris</i>	194
<i>Air Monitoring</i>	195
Cleaning And Dismantling Of Asbestos Removal Area.....	195
<i>Visual Inspections and Air Sampling</i>	195
<i>Inspections for Completeness of Removal</i>	196
<i>Dismantling Of Removal Area</i>	196
<i>Clearance To Reoccupy</i>	196
<i>Transport And Disposal Of Asbestos Waste</i>	196
Appendix - Documents available	197
Procedures	197
Safe Operating procedures	199
Forms.....	200
Risk Assessment	200
Training videos	201

Introduction

As an industrialised nation Australia has achieved high levels of consumption and correspondingly high levels of waste disposal. The construction industry is a major contributor to these levels of waste creation and consequently a major potential market for reused and recycled materials.

There is some research in Australia into recycling technologies, issues of embodied energy, and design for construction. This research is not however well integrated with the construction industry in general.

Demolition licencing

The owner may contact the licencing authorities in various state to verify the licence held by the Contractor.

Training required for Licencing

Varies from State to State

Safety

Being complacent towards hazards is a leading factor in most construction site accidents. Well over 100 Australians are killed each year as a result of work-related accidents and incidents.

Video - [Work safe for the moments that matter](#)

Safety is a consideration in everyday life. Yet whilst great emphasis is placed on safety as a title, it is important that we remember 'common sense' plays a part in the greater scheme of things.

Video - [Dumb ways to die](#)

Safety culture at the workplace is governed by a mass of regulations and rules. The risk that the rules present is that we can fall into the trap of 'it's someone else's responsibility, because it is not our immediate responsibility' and by doing that we forget to apply common sense. Safety in the workplace is always our responsibility that is what working in a team relies on.

Video - [Safety culture and climate in transport webinar](#)

The rules are there to inform you, and let you know what will happen if you don't follow them, but they will not make the final decision for you. Only you can do that by risk assessing and using 'common sense'. If an activity places you into a position where all of those inner alarm bells are ringing it is probably for good reason. If the cost outweighs the benefits, then listen to 'common sense'.

Video - [Safety leadership challenge - BMD](#)

Health and Safety needs to be taken seriously. The effects of accidents or deaths have a ripple effect - from the effects on the individual Worker, to the Worker's family, to the Worker's co-workers and production, to the organisation, to the community and to Australia. Costs can be indirect (e.g. personal costs, healthcare costs, legal costs, psychological costs, loss of earnings, pain and suffering) and may include the loss of life or permanent disability.

Video - [In it for the long haul](#)

Safety begins at the top. Employers have a duty of care (that is a legal obligation) to ensure that they provide safe systems of work and a healthy work environment for their workers.

Video - [Introduction to ergonomics in the workplace](#)

Environment

Australia has one of the highest rates of solid waste disposal in the world; to say it is on the increase is one of the all-time-great euphemisms. In 2000, nearly one tonne of solid waste is sent to landfill per person each year; approximately 14 million tonnes. Of this the amount, construction and demolition waste has been measured and estimated at from 16% to 40% (Philip Crowther (Qld University of Technology)). During 2010-11, the Australian economy generated 53.0 million tonnes of waste, including imports. This was a slight decrease on 2009-10 (53.8 million tonnes). Of the total waste generated 30.8 million tonnes (58%) was recovered with 22.2 million tonnes (42%) disposed to landfill.

The Construction industry and the Household sector each generated over 14 million tonnes of waste, representing over half (54%) of the total waste generated. The bulk of waste generated by the Construction industry was masonry. Masonry materials, accounted for 16.3 million tonnes (31%) of total waste generated in 2010-11, down from 19.8 million tonnes, or 37% of the total waste generated in 2009-10.

The Construction industry produced 10.9 million tonnes (67%) of all masonry waste in 2010-11, a 2.8 million tonnes (or 21%) decrease from 2009-10

Most waste is managed by the Waste Management Services Industry. This includes those businesses whose main activity is waste management as defined by the Australian and New Zealand Industry Classification (ANZSIC) 2006 (ANZSIC Division D, subdivision 29) and waste management activities of local government. Waste that is managed/treated by non-waste management businesses and exports of waste are also covered.

There are broadly three 'destinations' for Australia's waste:

1. Disposal to landfill (Waste that is buried in landfill or incinerated or any other permanent form of removing waste that is not recovered or reused in any way).
2. Recovered for the domestic economy (The process of extracting materials or energy from a waste stream through recycling or recovering energy from waste.).
3. Exports (part of total recovery).

Of the total waste generated in 2010-11, 30.8 million tonnes was recovered, which included 27.1 million tonnes domestic recovery and 3.7 million tonnes that was exported. Total waste sent to landfill was 22.2 million tonnes.

The largest reductions in waste materials sent to landfill were masonry (8.9 million tonnes in 2009-10 to 4.9 million tonnes in 2010-11), and paper and cardboard (2.5 million tonnes to 1.7 million tonnes). Plastic waste sent to landfill increased from 1.2 million tonnes in 2009-10 to 1.9 million tonnes in 2010-11.

The Waste Management industry accounted for 62% of the total tonnage for landfill and recovery. Businesses outside the Waste Management industry were responsible for 55% of the total waste recovered (Australian Bureau of Statistics).

Legislative Framework

In Australia, Work Health and Safety legislation is state and territory enacted, based on federal legislation. Details vary only slightly between the states and territories. Types of Acts and regulations in the health and safety area include:

Acts: legislation enacted by parliament which set the principles and philosophy

Regulations: which prescribe the requirements for complying with the Act.
Codes of Practice: provide practical guidelines for complying with the regulations
Australian Standards: prescribe specific standards (e.g. design standards)
The law in Queensland is set out in the *Work Health and Safety Act 2011*.

The Act aims to prevent a person's death, injury or illness being caused by a workplace or workplace activities, by eliminating or minimising exposure to risk.

Helpful links:

[Safework Australia](#)

[Safework NSW](#)

[Safework QLD](#)

[Safework Vic](#)

[Safework NT](#)

[Safework SA](#)

[Safework ACT](#)

[Safework Tasmania](#)

Other Legislation also applies

- Environmental
- Transport
- Employment and fair work
- Sale of Goods
- Various building licensing authorities
- Local Government in relation to building permits
- And more

Chapter 1 - Assess site and scope of work

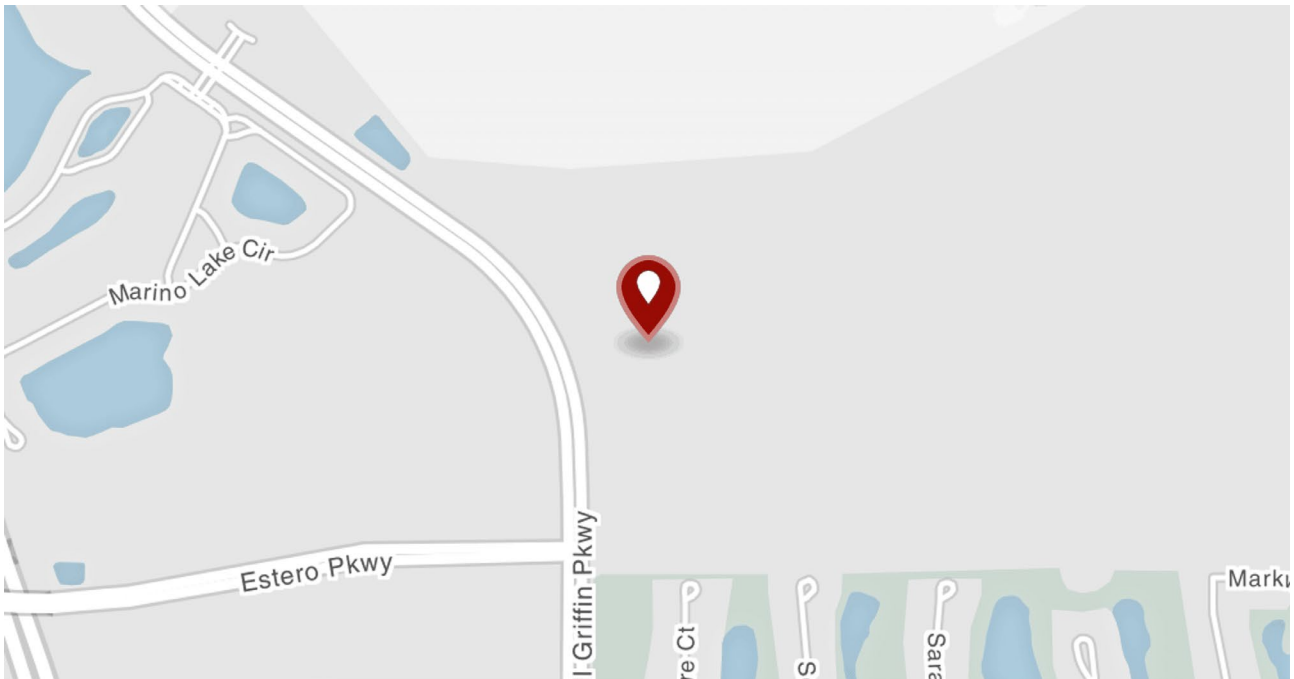

[For training materials Refer to appendix 2.](#)

Describe the construction process for a project

<p>What are the main structural components</p> <p>Structural building components. Structural building components are specialized structural building products designed, engineered and manufactured under controlled conditions for a specific application. They are incorporated into the overall building structural system by a building designer.</p> <p>Structural building components - Wikipedia</p>
<p>What Demolition is required</p> <p>Demolition work means work to demolish or dismantle a structure, or part of a structure that is load-bearing or otherwise related to the physical integrity of the structure, but does not include the dismantling of formwork, falsework, or other structures designed or used to provide support, access or containment during construction work; or the removal of power, light or telecommunication poles. Definition as per Work Health and Safety Regulation 2011 (the Regulation), Schedule 19 – Dictionary.</p>
<p>What Consultants are required</p> <p>Designer, Structural Engineer, Mechanical Engineer (air conditioning), Hydraulic Engineer (Water supply), Geotechnical Engineer (soils), Safety, Environmental, Electrical Engineer, Building Certifier,</p>
<p>Footing systems and how they will be constructed by “Understand Construction”</p> <p>http://www.understandconstruction.com/building-foundations.html</p>
<p>Wall systems and how you will construct them</p> <p>http://www.understandconstruction.com/walls.html</p>
<p>Roof systems and how you will construct them</p> <p>http://www.understandconstruction.com/roofing-systems.html</p>
<p>What cladding is nominated and how it will be installed</p> <p>http://www.understandconstruction.com/facade--curtain-wall-systems.html</p>

Waterproofing
http://www.understandconstruction.com/waterproofing-systems.html
Types of Construction
http://www.understandconstruction.com/building-foundations.html
Elements of Construction
http://www.understandconstruction.com/elements-of-construction.html
Building Materials
http://www.understandconstruction.com/building-materials.html

Client Project Needs

Before any work commences the scope of works and client requirements must be negotiated and discussed. The most effective and efficient way to do this is by holding an opening meeting with the client. This meeting sets the pace for the project, introduces all the key stakeholders and facilitates the building of key relationships required to perform the work to occur now and potentially, into the future. The project manager for the contractor establishes lines or methods of communication between his team, other contractors and the client, discusses milestone timeframes, project overview and special or specific considerations that need to be addressed (such as a heritage listed site or land of significant historical value etc).

An opening meeting needs to address critical aspects of the project. During the meeting, the following particulars need to be identified, investigated, and negotiated where necessary and actioned.

- Scope of work
- Client special requirements
- Confirm ownership
- Asbestos register
- Dumping of waste
- Ownership of demolition salvage or surplus materials
- Dilapidation survey
- Timeframe
- Plans / drawings

Not only must these particulars be discussed, they must be recorded in the project documentation and the outcomes of what the client requires, what is required by legislation and what the contractor can deliver.

Ownership

Once the opening meeting has end the contractor needs to determine that those claiming ownership are who they claim to be. This is done by performing a search to confirm the ownership of the property / site. The obvious point to take from this process is that if you are tendering for the contract, or it is work for a governing body such as a council, or bank in possession, most of the vetting has already been done to confirm that the client is the bonafide owner of the site / property. For other projects however, you need to make sure for your own security. The best way to do this is to go through:

- a Real estate lawyer ([Law societies](#))
- [local government records](#)
- private companies that specialise in [property information](#)

- Bank records / deeds,
- State government ([Departments of Commerce](#))
- [Title registers](#)

You must confirm the ownership of a property before you commence any works on it! Once you have confirmation that the client is indeed the owner and or is legally representing the owner, you can begin the project in earnest.

Assess site and scope of work.

- Project Plan is reviewed, and site inspected to evaluate size and complexity of demolition tasks.
- Concurrent work of other construction teams is assessed, and communication channels established or confirmed.
- Site access and egress and traffic management plan are assessed, and additional provisions or changes negotiated as required.
- Provisions for site storage and amenities are assessed and additional provisions or changes arranged as required.
- General site work health and safety (WHS) and environmental requirements are confirmed and applied to planning.
- Regulatory compliance requirements are confirmed and applied to planning.
- HAZMAT audits are arranged prior to work start date and findings are applied to planning.

Video - [Demo – Site investigation](#)

Video - [Demo - Ruinous-building](#)

Video - [Demo - Power-lines](#)

Create contractual documentation and QA processes

Plans & Specifications

Defining plans and specifications. Plans and specifications are defined by the Building Act 2004. They include: the drawings, specification and other documents (see below) from which the building is to be constructed, altered, demolished or removed. the proposed procedures for inspection during construction. May 16, 2018. [Refer to training materials Appendix 2](#)

The main purpose of **construction drawings** (also called **plans**, blueprints, or working **drawings**) is to show what is to be built, while the specifications focus on the materials, installation techniques, and quality standards.

Specification for construction. Specifications describe the materials and workmanship required for a development. They do not include cost, quantity or drawn information, and so need to be read alongside other information such as quantities, schedules and drawings. Aug 21, 2018

Requirements of site plan determined

The supervisor shall consult with Site Owner and other stakeholders to determine the scope of works, hazards on-site and how our works will affect other workers and members of the public who may be exposed to hazard and risk by our activities. The consultation outcomes shall provide a basis to write SWMS, WH&S Management Plans

Site inspection is conducted

For your inspections and monitoring activities to be effective you will need a thorough knowledge of worksite procedures. These will include all relevant workplace operating procedures, work instructions and temporary instructions.

All of these requirements are in place to ensure your worksite complies with the designated regulations and legislation.

It is important to make sure that the codes and standards you refer to are the most current versions as approved by state and federal government.

Purpose of Inspection

A work site inspection is required to identify the hazards associated with individual demolition hot work tasks and to identify how those tasks can be managed.

Development application.

Planning and Development applications should be lodged and added to your documents brief. Once again, each city / regional council has its own portal for development applications. Brisbane Planning and Development Online provide you with access to property, planning and development information.

Sample : [Brisbane City Council](#)

Building permit application.

Samples of development application, and building permits are found [here](#)

A **building permit** is an official approval issued by the local governmental agency that allows you or your contractor to proceed with a **construction** or remodelling project on your property. It is intended to ensure that the project plans to comply with local standards for land use, zoning, and **construction**. Feb 17, 2018

Usually approval is sought from the Local Council or Private Building Certifier.

Plumbing permit.

As the property owner, it is your responsibility – in conjunction with the designer – to ensure that a certificate of likely compliance and/or plumbing permit is in place before any plumbing work begins. If you don't think you need a permit, you should check with your building surveyor, designer and the registered plumber undertaking the project before you start work. You should also discuss with your building surveyor or designer if you need approvals. Note: there are substantial penalties for undertaking building and plumbing work without a permit. (TasWater)

Notification to Safety Authority

An on-line application in most States for appointment of a PCBU must be completed and lodged with the Portable Long Service Levy Board when submitting plans and prior to commencement of any work on site, where value of work equal to or exceeding \$250,000.00 (this value is different in each state) and where the prescribed activity of demolition work or asbestos removal work is undertaken. Access to the notification process can be gained from the State Regulators websites below.

The workplace number should be recorded on site for reference and a copy of the notification kept on file along with all other Workplace Health and Safety paperwork for the project.

List of contacts

[Queensland](#)

[NSW](#)

[Victoria](#)

[South Australia](#)

[Tasmania](#)

[Northern Territory](#)

[ACT](#)

Insurance.

Contractors' **all risks (CAR) insurance** is a non-standard **insurance** policy that provides **coverage** for property damage and third-party injury or damage claims, the two primary types

of **risks** on **construction** projects. ... Third parties, including subcontractors, may also become injured while working at the **construction** site. (Insurance Council)

Connect the town water.

Connection of water supply for use during construction can be achieved by applying for a temporary connection with the local Council

Connect electricity.

As there are now multiple supply options for electricity, you are now required to work with the electrical contractor to apply through your retailer. You may choose to use a temporary electrical supplier who specialises in supply site builders' poles and other temporary services such as toilets.

Work Schedule (GANTT chart or MS Project).

A work schedule or **Gantt chart** is a type of bar **chart** that illustrates a project schedule. This **chart** lists the tasks to be performed on the vertical axis, and time intervals on the horizontal axis. The width of the horizontal bars in the graph show the duration of each activity.

[Gantt chart - Wikipedia](#)

Contracts for Residential work.

Contracts are available from

[YOUR HOME](#), a Federal Government Consumer advisory service.

[HIA](#)

[Master Builders](#)

[Law Depot](#)

[ABIC](#)

[Victorian Government](#)

Requesting information

AT this stage of the process you should conduct another meeting with the client to affirm that all the scope and conditions for the project have been confirmed. The outcomes of this meeting must be recorded in the meeting minutes and attached to the project file. You may not need to request any new or missing information before moving forward however, if you do you want that information prior to launching the project itself. [Form sample - RFI](#)

Estimating the cost of the project

Identify the changes if any to contracts or your schedules that may be required by the final DA approval. The Development Approval may require you to add special conditions, these will all be treated as Variations.

Quick estimates

You should consider that many potential clients have no idea of the cost of their potential project. It may be prudent to do a quick estimate of cost rather than spend many hours doing an exact quote.

Consider using these apps that can be purchased on the App store

- [Quick chippy pro](#)
- [Quilder](#)

Supplier quotes

Obtain quotes from suppliers & subcontractors, to do so you will need to supply them with a copy of the Plans and specifications, and you may be asked for a bill of quantities

Bill of Quantities.

A Bill of Quantities is a detailed statement of work, prices, dimensions, and other details, for the erection of a building by contract. The list must include all your costs including your business overheads and your time not only for building but also for administration.

Form sample – [Bill of Quantities](#)

Quotation

What is usually included in a quote to build a project?

Form Sample - [Quote](#)

Master Builders Queensland's manager of building services, Tony Mitchell, says with no uniform laws across Australia controlling what is and isn't included in a standard building quote, it's up to the consumer to work with builders to define what's what.

- There's no uniform laws controlling what is and isn't included in a standard building quote.
- "Each and every builder across Australia will have their own template of what is included and what isn't, so during the quoting process, consumers need to be very specific about the scope of work they want done and then understand what is included and what isn't in the quote when it comes back," he says.
- "You need to consciously read and understand what you've been quoted for...and never assume,"
- For example, some volume builders take care of site costs, like engineering work, soil tests, unexpected tree removal or rock excavation, as well as council and regulatory requirements, but not all independent builders will.
- "Unless you can see it written down, you're not getting it, so check," he says.

Mitchell says things like driveways, landscaping and fencing are all generally treated as "extras" but can be included in an "all-in-one" quote if requested.



Picture: Getty Images

The actual inclusions in a property – things like appliances and light fittings – are listed in the specifications.

- "Make sure the specifications, as listed, are what you want."
- Pay careful attention to "prime cost" items, which are where a provisional amount is set aside for something, but not yet purchased, Mitchell says.
- "Ensure the allowances you have for things, it may be \$1000 for a cooktop, are actually sufficient for what you want," he says. If there's a difference, the consumer pays.
- Also, be aware that connections, like stormwater, gas, power and internet, are generally the responsibility of the owner, not the builder – and can be costly.
- While using a "turnkey" provider is different to engaging an independent builder, volume builders generally quote in a similar way, making it possible to compare.

Hotondo Homes' national sales manager Fred Abu-Elias says most builders will start with the base price, the inclusions and any added upgrades. "There are a number of components we include in our quotes; however, this can vary depending on the type of home you are building. The price will include the base price of the home itself and the standard inclusions; the type of flooring in the home, fixtures such as tapware and appliances and paintwork," he says.

"A quote will also include any upgrades the client has specified during their initial appointments. Some builders also include driveway or landscaping allowances."

What might not be included in a quote to build a project?

He says items buyers choose to upgrade throughout the process, like benchtops, fittings, appliances and structural changes, are not be included in the initial quote.



Picture: Getty Images

"Groundwork is also not included on split level homes, as it is hard to judge what work is required without visiting the block," Abu-Elias says. "Front and back landscaping is almost always an extra, as every client will have a different idea of what the perfect front or back yard is."

Burbank Homes' managing director Jarrod Sanfilippo agreed driveways, landscaping and fencing are treated as extra. "Other things to consider are town planning requirements, planning permits and occupational health and safety requirements when building within an established area, like traffic management," he says. "Some builders may have different clauses around their fixed site costs and so on, but they generally each share the same approach when it comes to quoting. Any good builder would be more than happy to meet with prospective buyers and discuss their options, which can be easier than them trying to figure it all out for themselves," Sanfilippo says.

Chapter 2 - Planning and preparing for work



Prepare a Project Management Plan (PMP)

This document will contain all planning for the project and will usually allude to or include the following plans or information

- Scope of works
- Plans & specifications
- WH&S Management Plan
- Environmental Management Plan
- Emergency Management Plan
- Quality Management Plan
- Work schedule (GANTT)
- Bill of Quantities
- Site establishment Plan
- Resources
- Methodology

Form sample - [PMP](#)

Video - [Understanding Hazards and Risks](#)

Schedule activities.

Project plan is analysed, and individual tasks prioritised according to WHS, site and resource requirements.

Concurrent tasks are planned and sequenced to maximise efficient use of resources. Resource hours required for individual demolition tasks are estimated with allowances for contingencies.

Timelines for different project stages are calculated, compared to demolition plan, and adjustments are made as required.

Project schedule is prepared, reviewed by relevant personnel, amended as required and processed according to workplace requirements.

Prepare safe work method statements for individual activities.

Hazards and risks associated with each demolition task are assessed by site inspection, discussion with relevant WHS and site personnel, and consideration of sequencing of tasks.

Risk management strategies are analysed according to the hierarchy of controls in consultation with relevant WHS and site personnel.

Safe work method statement (SWMS) is prepared for each task with instructions for review immediately before work starts to re-assess work site conditions resulting from previous tasks.

Video - [Safe work procedures & PPE](#)

Video - [Supervisors - site safety inspection sheet](#)

Video - [Supervisors - site safety inspection sheet](#)

Arrange resources for activities.

Resource requirements for tasks are confirmed, and requirements for concurrent tasks calculated according to project schedule.

Arrangements are made for delivery of required plant, tools and equipment according to project schedule.

Specialised skill requirements for different project stages are determined and skills of available team members assessed to identify skill shortages.

Recruitment of additional team members with required skills is conducted and completed within required timeframe for prompt start to work.

Team members are allocated to tasks and human resource requirements for all project stages are checked and confirmed as complete.

Conduct site induction and team briefing for the project.

Site tour and general site induction regarding safety and environmental requirements are arranged or conducted according to project and workplace requirements.

Details of task allocations and scheduling are explained and discussed, and team understanding of work requirements is confirmed.

Concurrent work of other construction teams, and interactions and communication channels, are explained and understanding of team members is confirmed.

Provisions for dealing with risks, hazards and contingencies are explained, and understanding of team members is confirmed.

Team members are encouraged to ask questions for clarification at all stages of the work and to provide suggestions for improvements in processes.

Video - [Involving workers to develop solutions for hazardous manual tasks](#)

Determining the training needs of workers

The provision for providing training is a requirement under the Work Health and Safety Regulations 2011.

The person must ensure that information, training and instruction provided to a worker is suitable and adequate having regard to:

- *the nature of the work carried out by the worker; and*
- *the nature of the risks associated with the work at the time the information, training or instruction is provided; and*
- *The control measures implemented.*

The person must ensure, so far as is reasonably practicable, that the information, training and instruction provided under this section is provided in a way that is readily understandable by any person to whom it is provided.

The best way to determine what those training needs are is to conduct Training needs analysis (TNA). You can see an example of a [TNA here](#).

A TNA matches a qualification against a task or profession and details the 'skills set' required for that task or profession. Then, once the tasks are mapped against the people, the supervisor or person conducting the TNA, can recruit workers or train their current workers in the skills 'gap areas' for those tasks.

Assess potential impacts of tasks.

Environmental and public health and safety compliance requirements for the site and geographic locality are determined.

Safe work method statements ([SWMS](#)) for individual tasks are reviewed and potential impacts on environment are determined.

Safe work method statements for individual tasks are reviewed and potential impacts on public health and safety are determined.

Identify measures to minimise impacts of work on the environment.

[Refer to Chapter - Protect the Environment](#)

Identify measures to minimise impacts of work on the public.

Site containment, exclusion and signage strategies are reviewed and amended to maximise awareness of, and minimise impacts on, the public.

Pedestrian and traffic management plan for site and site perimeter is reviewed and amended to minimise risks to the public.

Fall prevention strategies for both personnel and materials are reviewed and amended to minimise risks to site personnel and the public.

Noise, air pollution and vibration management strategies are reviewed and amended to minimise impact on the public.

Brief team and supervise implementation of impact minimisation strategies.

Strategies for minimising impact of work on the environment and on public health and safety are explained to teams.

Amended safe work method statements are distributed and questions invited and responded to, as required.

Implementation of strategies to minimise impact of work on the environment and on public health and safety is monitored and directed.

Video - [Reducing the risk of manual tasks injuries in the workplace](#)

Supervise preparation for work.

- *Permit applications* for different tasks are processed and confirmed as compliant prior to starting work.
- Work instructions for individual *demolition tasks* are communicated to team members and questions invited and addressed.
- Team member understanding of work health and safety (WHS) and environmental requirements is confirmed.
- Team members' selection of plant, tools and equipment is confirmed as consistent with job requirements.
- Reported plant, tool and equipment faults are processed according to workplace and WHS requirements and replacements are sourced as required.
- Team members' manual handling and placement of plant, tools and equipment at the site are monitored and directed to ensure safety and efficiency.

Video - [Supervision in Construction](#)

Video - [A Back Injury Can Change Your Life](#)

Video - [Lifting in the Workplace](#)

Establish a folder for each project

Create an individual folder for each project and file all documentation. This provides the information required to create site specific documents for a project. The minimum requirements are “bolded topics”

Documentation set-up checklist

As with all management, you will utilise various documents and forms to plan, track and evaluate the progress or stages of a project. The document set-up checklist lists each evidential document required for the successful execution of a demolition project. As you complete each part of the process in the project verify by completing the checklist against the appropriate step. There should be an annotation for each process in your project.

Ensure documentation for each new project is established

- Tender documents
- Use “Project set-up document” to ensure appropriate documents are on-site
- Plans & specifications entered in Drawings issued
- A copy of appropriate forms is available to site

Drawings issued

All drawings issued for a project shall be recorded. Notify contractors of new issues.

File a copy of new documents and “Archive” old copies. Obtain an acknowledgement from each contractor. Form sample- [Document / drawing register](#)

Request for information

Record all information requests and be reminded of the actions required. Ensure all responses are filed in this folder. **Form sample** -[RFI](#)

Site diary

Record day to day activities on site daily and have information available live to Head office. This will provide documentation of site activities such as Weather, Worker numbers, Visits to site, Materials delivered and so on. **Form sample-** [Site Diary](#)

Condition / Dilapidation reports

A dilapidation report is a report on the condition of a property at a given point in time. It records any existing damage, and the state of any particular aspects of the property that are likely to be affected by construction work, excavation or demolition.

These reports are normally carried out on nearby properties both before work begins, and after it's finished. Comparing the two reports offers a clear picture of any damage that might have occurred as a result of building, excavation or demolition work.

Dilapidation reports are normally carried out by experienced building consultants, or prescribed consultants for Heritage sites, who have a good understanding of the aspects of a house or property that are likely to be affected by nearby works, and who know exactly what to look for. You can source a provider / contractor simply by using google search

Dilapidation reports typically include things like notes, measurements, photographs and diagrams which give an accurate picture of the state of the buildings being inspected and are normally signed by both the owner of the property being inspected, and the party having construction work done.

Create supplier contracts or purchase orders

Subcontract Agreement

Agreement, purchase order, or any such legal instrument issued under a prime **contract** (by the prime contractor to a third party the **subcontractor**), calling for the performance of a defined piece of work or production and/or delivery of specified goods or services.

Contract of supply

Complete a Contract for supply of goods and or services (or purchase orders), include all information from the plans or specification by referring to page numbers or specification number. It is usual to establish contracts of supply with Building material suppliers or they may increase the price during construction, and you may not be able to claim the increases from your client.

Purchase orders

You will need to be able to create purchase orders for materials for a site.

If you are using a Mac, double click on the Word icon in your dock. If you are using a PC, click on the Windows icon in the lower left-hand corner of your desktop. Click on the Windows tile. You will see a screen that shows you all of the pre-made templates Word has available. In the search bar, type “Purchase Order.”

Review the different purchase order templates and select one with a layout you like. Look for one with enough room for all of the lines you want to include on your purchase order. Double click on the icon of the template you want to use. This will open the document. Word has created the template using a table. You can use the table formatting options to customize the template to meet your needs.

You can also create purchase orders through your organisation's accounting [software](#).

Form sample- [Purchase order](#)

Chapter 3 - Identify and Assess Risk

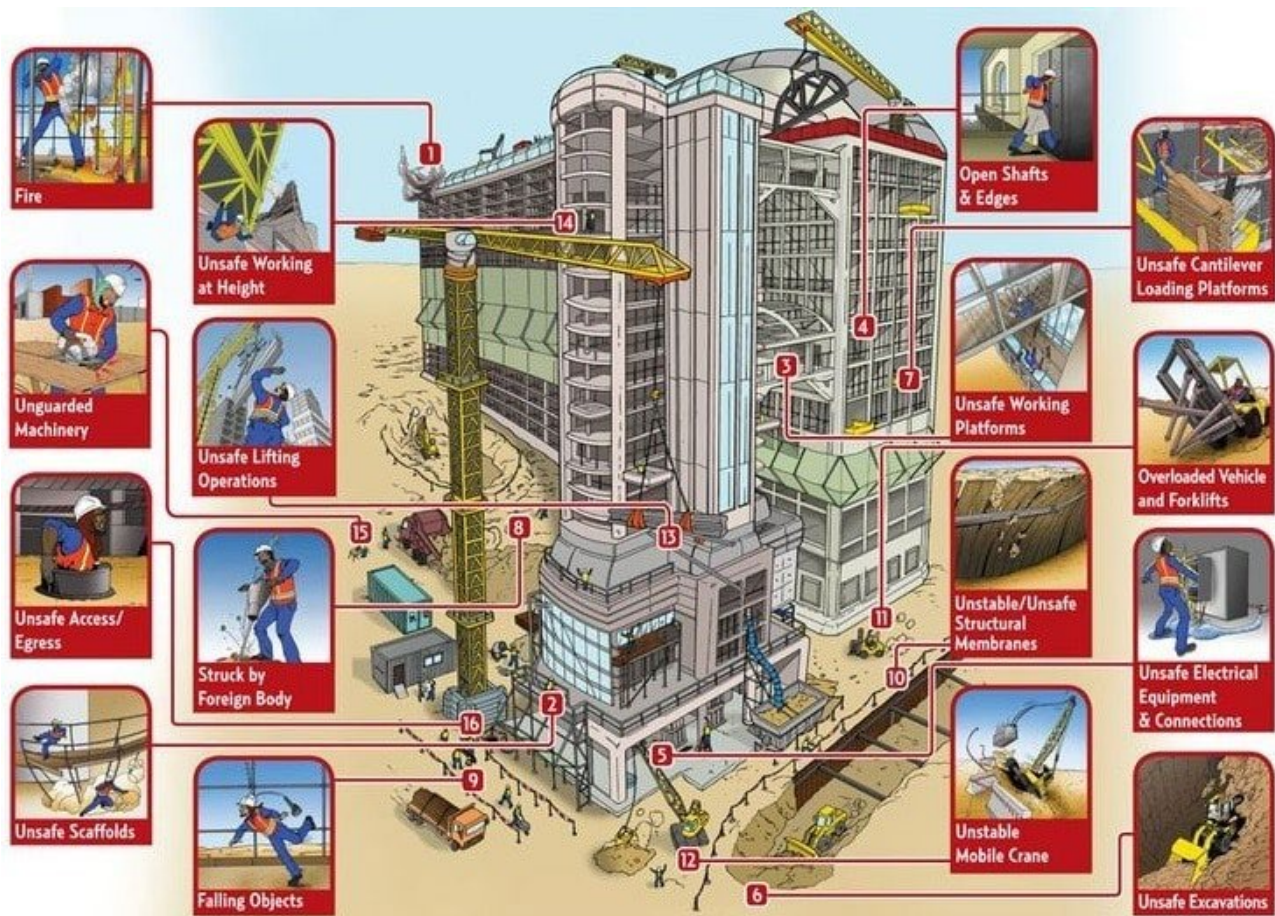

Taking care of safety

Safety is a huge responsibility on a construction site and is often undervalued because the benefit of a great system is that nothing happens. If you can make health and safety look easy you are very good at your job. The challenge in this role is that very few people assign the same level or importance or priority to safety unless they have been involved in a serious incident then. The harsh reality of work health and safety is that it costs a lot to maintain a compliant site and that no amounts of money that an incident / accident victim might get in a compensation claim will ever replace that faculty or functionality that was damaged in the accident.

Safety on a construction site starts with the identification of hazards and calculation of risk. This process is called Risk Management and is done through the use of a Risk Assessment.

The reason you identify potential hazards on a job site is so that you can then determine how dangerous the activity actually is. Once you understand how dangerous the demolition job is, or the threat that activity poses to the workers, public and environment you can put effective controls in place to mitigate that risk. If you don't perform a risk assessment, you have no idea as to the level of risk and thus can't implement an effective risk management strategy. In addition, it is a legal requirement that you utilise risk management strategies to minimise the risk posed by the activities that you, as the contractor, create through the scope of your work (Commonwealth of Australia).

A regulation is legislation made by the Minister to deal with matters of an administrative nature; or prohibit exposure to risk; or prescribe ways to prevent or minimise exposure to risk. Where a regulation defines the way to do the work it must be followed.

Hazard Identification

[Refer to Training materials - Appendix 2 Hazard Identification](#)

Video - [Introduction to ergonomics in the workplace](#)

Video - [Slips, Trips, and Falls](#)

Video - [Remote and isolated work](#)

WH&S Management Plan (WHSMP)

The WHSMP is the primary document for the planning, execution and completion of the project. It contains essential information for the project. The document describes a logical progression through the process. The primary components of a WHSMP are:

- Project details
- Site plan
- Resources (plant, contractors, specific training, hazardous substances)
- Safe operating procedures
- Legislation and related documents
- Site-specific information
- Site preparation
- Work methodology
- Worker training for the project (TNA)
- Work schedule
- Emergency management plan
- Environmental hazards

Form sample- [WHSMP](#)

Traffic management

You should conduct a meeting with the client to review the risk management control measures to be implemented to mitigate the risks posed by the movement of vehicles on site and around the site on public roads, across driveways etc. Based on your organisation's risk appetite and worker qualifications, you may need to engage a traffic management company to set up exclusion zones around the job site.

Video - [Worksite Dangers for Traffic Control Persons](#)

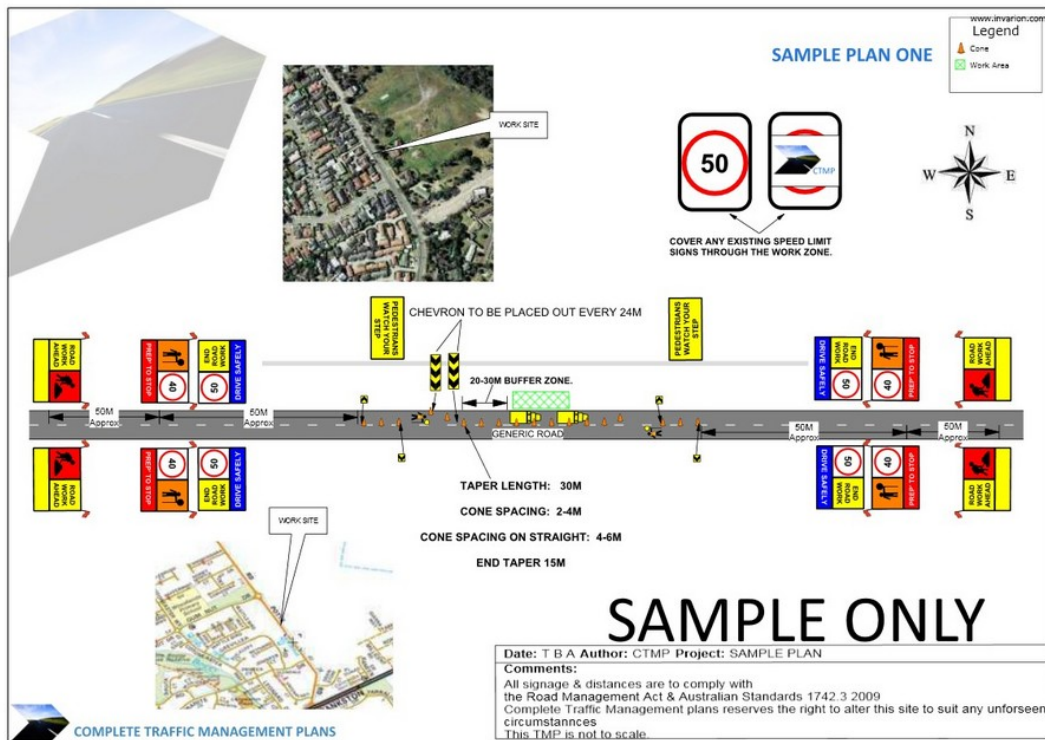

It is critical that all aspects of risk management control strategies be discussed with all stakeholders on the project, including sub-contractors, apprentices, neighbours and suppliers.

A traffic management plan documents and helps explain how risks will be managed at the construction workplace. This may include details of:

- designated travel paths for vehicles including entry and exit points, haul routes for debris or plant
- and materials, or traffic crossing other streams of traffic
- pedestrian and traffic routes
- designated delivery and loading and unloading areas
- travel paths on routes remote from the workplace including places to turn around, dump material, access ramps and side roads
- how often and where vehicles and pedestrians interact
- traffic control measures for each expected interaction including drawings of the layout of barriers, walkways, signs and general arrangements to warn and guide traffic around, past or through the workplace or temporary hazard
- requirements for special vehicles like large vehicles and mobile cranes
- requirements for loading from the side of road onto the site
- the responsibilities of people managing traffic at the workplace
- the responsibilities of people expected to interact with traffic at the workplace
- instructions or procedures for controlling traffic including in an emergency, and
- how to implement and monitor the effectiveness of a traffic management plan

The outcomes of this meeting must be recorded in the meeting minutes and attached to the project file.

Form sample- [TMP](#)

Apply Safe Work Practices

Identify High-Risk tasks

Identify all high-risk tasks ensure

- a SWMS is developed,
- workers are trained,
- a tool-box talk is conducted,
- control measures implemented
- Monitor & review to ensure on-going safety.

The following task are considered as High-risk construction tasks:

Young workers

Yong workers are due special consideration. They do not have experience and may lack the skills to “See it coming”. Take the time to teach them the task, provide supervision and be available to provide assistance. View the following videos for hints and guidelines

Video - [Young and New Worker Programs](#)

Work at heights

[Refer to Training materials - Appendix 2 Work at heights](#)

[Permit to work](#)

Use of Plant

[Refer to Training materials - Appendix 2 Plant operations](#)

Use of Hazardous chemicals

[Refer to chapter “Identify Hazardous materials”](#)

[Permit to work](#)

Excavation

[Refer to Training materials - Appendix 2 Plant operations](#)

[Permit to work](#)

Work over water

[Refer to Training materials - Appendix 2 Hazard Identification](#)

[Permit to work](#)

Work near live electrical

[Refer to Training materials - Appendix 2 Hazard Identification](#)

[Permit to work](#)

Video - [Stay safer up there, switch off down here](#)

Confined space entry

[Refer to Training materials - Appendix 2 Confined spaces](#)

Permit to work

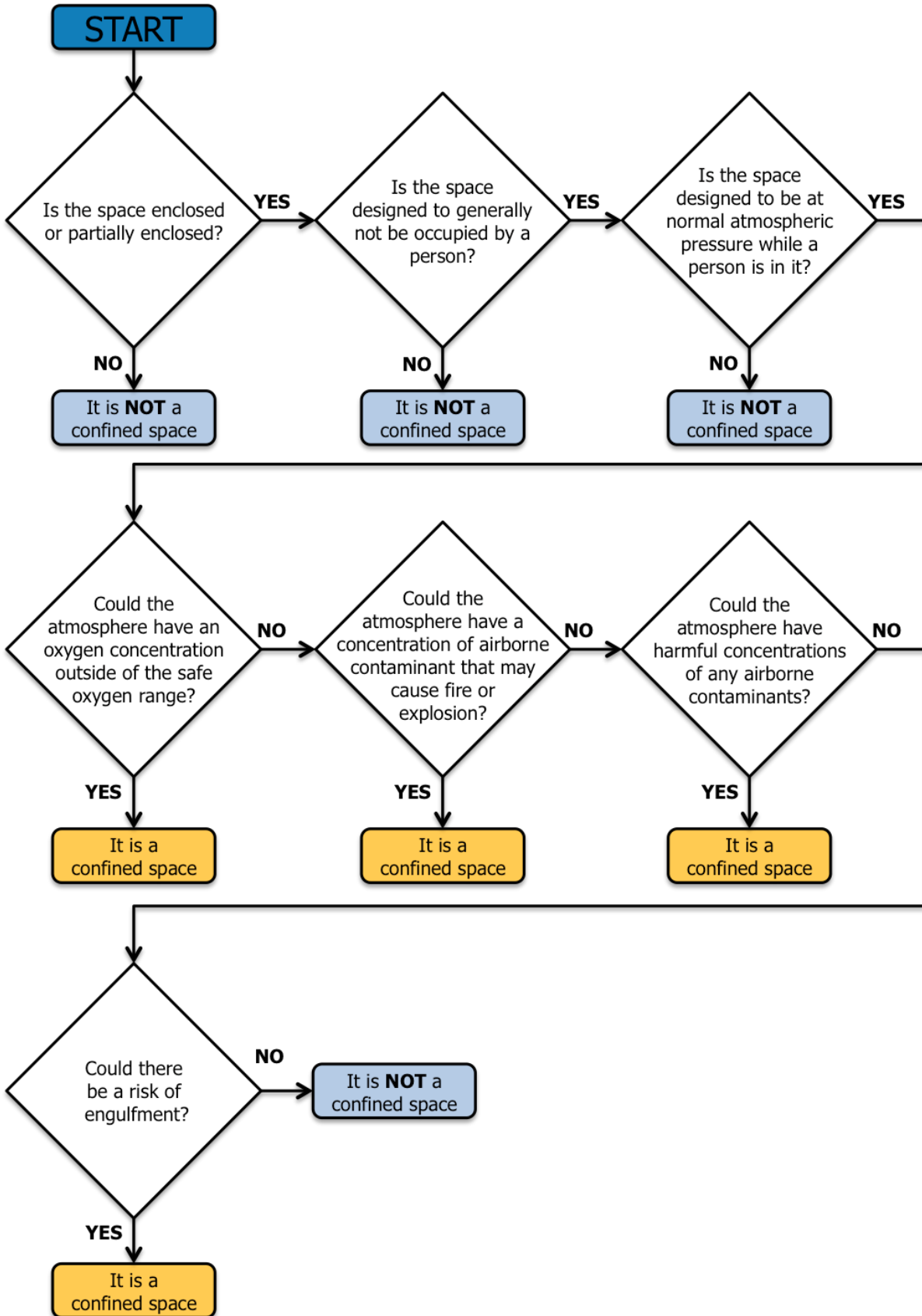

Inductions / Toolbox talks

A person conducting a business or undertaking must ensure that general construction induction training is provided to a worker engaged by the person who is to carry out construction work, if the worker (Workplace health and safety Electrical Safety Office Worker's Compensation Regulator):

- has not successfully completed general construction induction training; or
- Successfully completed general construction induction training more than 2 years previously and has not carried out construction work in the preceding 2 years.

Each company will address their site induction according to the policies and procedures of that company. A site induction may include (but not be limited to):

- Company safety policies, procedures and forms
- Work instructions and procedures
- Site rules
- Key health and safety staff/stakeholders
- Supervisors and managers
- Site safety locations and equipment
- Evacuation procedures
- Required PPE
- Codes of conduct
- Smoking policies
- Personal details – bank accounts, superannuation, next of kin etc.

An induction is an organisation's way of getting you off to a good start within your employment relationship and includes information on how work is to be done, what you will be responsible for, who to report to and what procedures you must follow. This information includes specific instructions on how you must work to keep yourself and others safe.

Inductions must be scheduled, and the results recorded. All workers, whether they be a standard labourer, tradesperson, TA, volunteer, delivery person or an officer for the PCBU must attend an induction before starting work on a demolition site.

Form sample - [Meeting](#)

Form sample - [Induction record](#)

SWMS

The aim of a SWMS is to:

- describe the activity or task to be undertaken
- identify the resources, manpower and skills associated with the task
- assess and select control measures (as appropriate)
- Systematically plan the activity so it can be completed efficiently and effectively.
- The SWMS must be able to be easily read by those who need to know what has been planned to manage the risks and implement the control measures and ensure the work is being carried out in accordance with the SWMS.

This includes:

- the supervisor of the high-risk construction work
- the worker carrying out the high-risk construction work
- The principal contractor (if it is a construction project) or the person who has management and control over the high-risk construction work.

When preparing a SWMS, the following must be taken into account:

- the circumstance at the workplace that may affect the way in which the high-risk construction work is carried out
- On a construction project, the WHS management plan prepared by the principal contractor.
- identify the work that is high risk construction work
- specify hazards relating to the high-risk construction work and risks to health and safety associated with those hazards
- describe the measures to be implemented to control the risks
- Describe how the control measures are to be implemented, monitored and reviewed.

A SWMS should also include the following information:

- the PCBU name, address and ABN
- details of the person(s) responsible for ensuring implementation, monitoring and compliance with the SWMS
- if the work is being carried out at a construction project:
 - the name of the principal contractor
 - the address where the high-risk construction work will be carried out
 - the date the SWMS was prepared and the date it was provided to the principal contractor
 - the review date (if any).

Form sample - [SWMS](#)

SWMS checklist

The primary purpose of a SWMS is to help supervisors, workers and any other persons at the workplace to understand the requirements that have been established to carry out the high-risk construction work in a safe and healthy manner (Safe Work Australia).

The SWMS:

- sets out the work activities in logical sequences
- identifies hazards
- Describes control measures.
- Both simple and complex activities can be broken down into a series of basic steps that will allow for full analysis of each part of the activity for hazards and potential incidents. The description of the process should not be so broad that it leaves out activities with the potential to cause incidents and prevents proper identification of the hazards nor is it necessary to go into fine detail of the tasks.

Form sample – [SWMS Checklist](#)

Safe operating procedures

Safe Operating Procedures are the documents that explain in a step-by-step manner about the scope and purpose of an activity, the list of tasks, sequence of tasks, who need to perform, how to perform and expected quality, resources and time. SOPs are a great step towards process improvement. SOPs help the organisation to freeze the current best practices of the organization and as and when things are improved the SOPs are revised to incorporate the new best practices. In other words, SOPs establish a baseline of performance that is expected within an organization. Apart from the above SOPs are helpful in continuous training of the workers to ingrain the best practices and a source document for training the new workers.

Although there are many versions of safe work practices across many different workplaces, there are essentially 3 practices that underpin all others:

1. Workers must not place themselves or others at risk
2. Workers must carry out tasks or use equipment according to any and all safety instructions
3. Workers must cooperate with employers and follow all systems or procedures in the workplace to the extent necessary to ensure compliance with Legislation.

To ensure that Work Health and Safety legislative requirements are met, organisations will develop **procedures** and **policies** ([rules and guidelines](#)) to help them, and their staff, identify hazards, manage risks and comply. **Form sample – [SOP Template](#)**

Equipment inspections

The most critical aspect of using equipment is the initial inspection. Inspections should occur:

- Inspect new equipment promptly upon receipt.
- Inspect v before each use.
- Check the condition of equipment that have been dropped or have fallen before using them again.
- Inspect equipment before storing to make sure they are in good condition to store, or need repair, replacement or remove from the site.

Form sample – [Plant Pre-start](#)

Video - [Plant - pre-start](#)

Site hazard inspections

Site inspections are an integral strategy in managing risks on a construction site. A site inspection covers every aspect of the site and is extensive. A site inspection must be specific to each site.

[Site inspections](#) should occur daily, prior to the commencement of operations and again at the end of the day (end of day inspection).

Form sample – [Site hazard inspection](#)

Video - [Supervisors - Hazard inspection residential, Supervisors - Hazard inspection residential 2](#)

Daily pre-start checklist

A daily checklist helps your track the process in a project management capacity. The checklist verifies that you have addressed key safety requirements on a demolition site and note any comments for future review. **Form sample - [Daily pre-start](#)**

Drugs and Alcohol

A nil tolerance policy must be adhered to

Video - [A Deadly Silence: Substance Abuse and Accidents](#)

Video - [Drugs and alcohol - Toolbox](#)

Chapter 4 – Identify Hazardous Materials



Hazardous chemicals

Any and all hazardous chemicals must be approved for use and tracked through the Hazardous Chemicals register that MUST be on site at all times. Each worker that is going to be handling, using or be exposed to the chemical must be competent in its use and control. A spill kit should be included in every vehicle that transports hazardous chemicals and an emergency procedure must be implemented in the event that an accident occurs.

Video - [Hazchem - Hazardous Substances](#)

Video - [Hazchem - SDS](#)

Video - [Hazchem - Shipping Container Explodes](#)

Video - [Chemical security for employees](#)

Video - [Shipping Container Explodes, Injuring Worker](#)

Video - [Chemical security for small business owners and managers](#)

Hazardous chemicals Register

A Register shall be created that identifies the following

- Quantity on-site
- Purpose
- Who is using it?
- Location of use and storage

A copy of the Safety Data Sheet (SDS) shall be kept, a risk assessment completed to identify potential hazards considering the contents of the SDS and can a less harmful substance be used instead. Workers who may be impacted by the Chemical shall be trained in its use.

Form sample – [Haz Chem register](#)

Video - [Pesticide Storage](#)

Silica

The new big thing. Ensure you seek advice of an appropriately qualified professional to establish appropriate training and procedures.

Video - [Silica Exposure](#)

Video - [Construction dust: respirable crystalline silica](#)

Asbestos removal clearance certificate

Whenever asbestos is identified in your project you must remove it in accordance with legislative frameworks and directions. Before general renovation or demolition work can start, a clearance certificate must be issued to categorically state that the site is cleared of asbestos. The following requirements must be met:

- An independent competent person must carry out a clearance inspection for class B asbestos removal work. A competent person can be from the business that carried out the class B asbestos removal work, providing the competent person was not involved in the removal of the asbestos.
- A competent person must not issue a clearance certificate unless satisfied the asbestos removal area and the area immediately surrounding it are free from visible asbestos contamination. Visible asbestos contamination would include any visible asbestos-contaminated dust and debris or asbestos waste that has not been properly contained and labelled for disposal.
- Inspectors can take enforcement action against a competent person who issues a clearance certificate improperly. In addition, an inspector can issue an improvement notice or prohibition notice to the licensed asbestos removalist who carried out the class B asbestos removal work and direct the removalist to take steps necessary to ensure the asbestos removal area, and the area immediately surrounding it, are free from visible asbestos contamination.
- The licensed asbestos removalist must then ensure a clearance inspection of the asbestos removal area is carried out by a new competent person who is completely independent from the removals.

A clearance certificate must be provided in writing by the licensed asbestos assessor or competent person who carries out the clearance inspection following licensed asbestos removal work.

- A clearance certificate can only be issued if the licensed asbestos assessor or competent person is satisfied that:
- the asbestos removal area and the area immediately surrounding it are free from visible asbestos contamination
- If air monitoring was carried out as part of the clearance inspection, the monitoring shows asbestos fibre concentration is below 0.01 fibres/ml.

A clearance inspection is required when a person commissions licensed asbestos removal work to be carried out at a workplace. Licensed asbestos removal work is asbestos removal work which requires either a:

- class A asbestos removal licence
- Class B asbestos removal licence.

A class A asbestos removal licence is required for removal of friable asbestos or asbestos contaminated dust or debris (ACD) other than ACD which is either:

- associated with the removal of non-friable asbestos; or
- Not associated with the removal of friable or non-friable asbestos and is only a minor contamination.

A class B asbestos removal licence is required for either:

- removal of more than 10 square metres of non-friable asbestos or asbestos containing material (ACM); or
- ACD associated with the removal of more than 10 square metres of non-friable asbestos or ACM.

[Queensland Government Clearance certificate](#)

[Video - Asbestos](#)

[Video - Working safely with asbestos for the home renovator](#)

[Video - Dear Dad - an asbestos awareness film](#)

[Video - Asbestos in Construction](#)

[Video - Asbestos Hazards in Renovations, Restorations, and Demolition](#)

Chapter 5 – Protect the Environment



Environment Management Plan

This Plan is intended to provide guidance and the methodologies to minimize harm.

Form sample – [Environmental MP](#)

Identify measures to minimise impacts of work on the environment.

- Strategies to minimise impacts on air quality are investigated, selected and incorporated into procedures.
- Strategies to minimise water wastage and impacts on stormwater are investigated, selected and incorporated into procedures.
- Strategies to minimise energy wastage and employ renewable energy technologies are investigated, selected and incorporated into procedures.
- Strategies to minimise material wastage and to ensure safe disposal of hazardous and waste materials are investigated, selected and incorporated into procedures.

Environmental considerations meeting (Harmonisation)

As previously mentioned, there is a significant environmental impact when deconstructing or demolishing a structure and removing the waste materials for disposal. The issues, scope of works, impacts, and legislative requirements can all be addressed through the use of an Environmental Management Plan (EMP). An EMP is a legislative requirement and must contain this information:

- EPBC number
- project name
- date
- proponent /approval holder and ACN or ABN
- the proposed/approved action
- location of the action
- date of preparation of the environmental management plan
- Person accepting responsibility for the environmental management plan – signed declaration.

Form sample – [Environmental harm checklist](#)

Video - [ENV - Toolbox - Water Conservation](#)

An [environmental management plan](#) (Form sample) identifies every aspect of the deconstruction process in respect to the environment and the impacts on the environment. It is a structured document that identifies the hazards, measures the risk, nominates the controls and explains the entire process.

An environmental management plan should (Commonwealth of Australia):

- be balanced, objective and concise
- state any limitations that apply, or should apply, to the use of the information in the environmental management plan
- identify any matter in relation to which there is a significant lack of relevant information or a significant degree of uncertainty
- include adaptive management strategies for managing uncertainty
- be written in a way that is easily understood by other parties
- clearly present how conclusions about risks have been reached
- ensure that the person taking the action takes full responsibility for the content and commitments contained in the plan.

The information outlined in the EMP should be discussed in a team meeting that discusses all of the environmental and public health issues required under legislation for the project. The details of this discussion should also be recorded and signed off so that everybody included in the project / scope of works understands their responsibilities and obligations for the project.

Environmental permit

Based on the outcome of the environmental management meeting an environmental permit should be created. It must contain:

- Site name and location
- Name of contractor performing the task
- Dates for start and completion
- Environmental risks
- Emergency equipment
- Emergency procedures
- Any calibration servicing on equipment
- Insurance and supplier
- Notifications to the regulator
- Scope of works
- Sign off area

Key resources for the construction of and environmental legislation are:

QLD: <https://www.ehp.qld.gov.au/management/index.html>

NSW: <http://www.epa.nsw.gov.au/>

SA: <http://www.epa.sa.gov.au/>

WA: <http://www.epa.wa.gov.au/Pages/default.aspx>

VIC: <http://www.epa.vic.gov.au/>

TAS: <http://epa.tas.gov.au/epa/>

NT: <https://ntepa.nt.gov.au/>

Form sample – [Permit](#)

Manage recyclables & waste

[Refer to Training materials - Appendix 2 Manage recyclables and waste](#)

Chapter 6 – Emergency Management



Emergency Management Plan

An Emergency Management Plan shall be written in consultation with stakeholders and its contents discussed with all workers prior to commencement of work as part of their site induction process.

A Disaster and Recovery Plan is essential Government templates are available [here](#)

Video - [Expect the Unexpected: Emergency Preparedness](#)

Video - [EMP - Toolbox - Emergency and Evacuation](#)

Video – [EMP - Toolbox - Fire Prevention](#)

Form sample – [Emergency MP](#)

Emergency information signs









- green solid, white symbol/writing (shows you where emergency equipment or access is located)

Fire signs

- red solid square, white symbol / writing (identifies location of fire alarms and equipment)

Video - [EMP - Emergency Fire Evac](#)

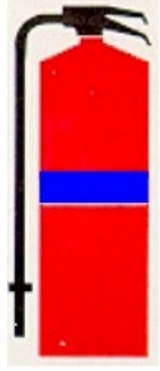
Portable fire extinguishers are distinguishable by their labels and their colouring. Commonly used portable fire extinguishers have a red background and coloured band to identify their classification.

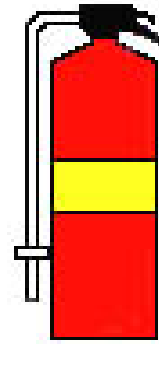
Type or Indicator					
	WATER	FOAM	CARBON DIOXIDE	DRY CHEMICAL	VAPOURISING LIQUID
					
Classification	A	AB	BE	BE / ABE	AF

Incident investigation

Incident investigations help determine the causes of an incident so you can take steps to ensure that the same incident will not happen again.

Employers are required to investigate and document the following incidents:

- serious incidents
- incidents that result in injuries that need medical treatment
- incidents that have the potential for serious injury (for example, near misses).
- Employers are not required to investigate motor vehicle accidents that occur on public streets or highways; local police generally investigate such accidents.

As much as possible, an investigation must:

- determine the causes of the incident
- identify any unsafe conditions, acts, or procedures that contributed to the incident
- find ways to prevent similar incidents (be aware not to introduce new hazards)

The investigation should answer the following questions:

- Who was involved or injured?
- Where did the incident happen?
- When did it occur?
- What were the causes?
- Why was an unsafe act or condition allowed?
- How can similar incidents be prevented?

Usually there are several factors that cause or contribute to an incident. Try to identify as many causes as possible.

Factors to consider when investigating an incident include:

- unsafe or defective equipment

- unsafe environment or conditions
- poor housekeeping
- physical hazards
- poor planning
- poor instruction
- unsafe work practices
- unusual or unfamiliar work conditions
- personal factors

(Worksafe ACT)

A well-completed report will promote an effective incident management process for incidents which are not “notifiable incidents”. A good incident report will ensure questions relevant to who, what, when, where, how and why are completed. Construction companies have policies and procedures that will guide the level of detail required in the incident report; along with the appropriate use of personal information, and matters relating to privacy and confidentiality.

Characteristics of a good incident investigation report

Video - [EMP - Incident Investigation Reporting](#)

Video - [EMP – Toolbox - Incident Investigation Reporting](#)

A good report is complete.

A complete report will cover the; who, what, where, when, how and why. The emphasis placed on each of these questions will vary based on the type and complexity of the incident.

A good report is concise.

It may seem contradictory to say that a report should be both complete and concise. However, concise means ensuring all the important details are included. Omit words that do not add value and interfere with readability.

For example:

- *Wordy* – “at this point in time, it has been determined necessary that we submit an incident report form”.
- *Concise* – “we should submit an incident report”.

A good report is specific.

Vague reports do not give much information. Ensure the dates, times and content is specific.

For example:

- *Vague* – “the worker had a high fever”.
- *Specific* – “the worker had a fever of 39°C”.

A good report is factual and objective.

Well-written incident reports are factual, fair and impartial. A fact is something real that can be either proved or disproved. Opinions and inferences should be avoided.

For example:

- *Inference* – “he was under the influence of alcohol as we smelt alcohol on his breath and his speech was slurred”.
- *Factual/objective* – “blood tests confirmed the driver had a blood alcohol level that was twice the legal limit”.
- *Opinion/subjective* – “the patient is an alcoholic”.

A good report is de-identified where appropriate.

- In the 'what happened' *incident summary* and *details* fields in the incident report it is best to ensure all information is de-identified.
- Avoid using people's names or identifying information.
- Details identifying individuals may be included in the 'who was affected', 'who is reporting' and 'witness/others involved' fields of the incident report.

A good report is light on abbreviations.

Including standard abbreviations or acronyms in [incident reports](#) is acceptable. However, using too many abbreviations or acronyms or using them inappropriately can detract from your description and make it hard to understand.

Meeting – Incident investigation (research)

Conduct a meeting with your work group and present your findings, justifying how your research will reduce the risk score to acceptable levels. Consider that the following may need to be amended or provided

- Training
- Company Policy & Procedures
- SOP
- SWMS
- Management Systems

Consider the true cost of an incident. You may be surprised at the actual cost. Remember the time taken to investigate and the time spent by everyone discussing the patient's misfortune and the rumour mill. All of this costs the company money.

This research includes a review of all the site safety systems to ensure that they are still current, fully operational and effective. This includes a review of all worker qualifications and training to discern whether gaps exist in their skills and knowledge or not.

Form sample – [Incident investigation](#)

Form sample – [Incident statistics](#)

Form sample – [Costs of incidents](#)

Return to work

The Company must have return to Work procedures and management processes. Most smaller businesses use an outsourced provider.

Video - [2 key changes to get workers back to work faster](#)

Video - [Young workers returning to work](#)

Chapter 7 – Site Operations



Plant operations

[Refer to Training materials - Appendix 2 Plant operations](#)

Video - [Compactor Rollover Injures Operator](#)

Video - [Struck by Mobile Equipment](#)

Small plant is operated according to manufacturer specifications

[Refer to Training materials - Appendix 2 Use small plant & equipment](#)

Video - [Angle Grinders](#)

Video - [Circular Saw Guarding](#)

Video - [Circular Saw Kickback](#)

Video - [Safe Handling of Nail Guns](#)

Video - [Nail Gun Safety](#)

Video - [Guarding for Woodworking](#)

Communication is maintained with team members

A **Toolbox Talk** is an informal **safety** meeting that focuses on **safety topics** related to the specific job, such as workplace hazards and safe work practices. Meetings are normally short in duration and are generally conducted at the job site prior to the commencement of a job or work shift.

A toolbox talk must be held regularly.

Work site conditions and progress are monitored in consultation with team

As the supervisor, it is your responsibility to conduct regular monitoring of tasks and activities to ensure that any changes in conditions are identified and responded to quickly.

Video – [Supervisors - conduct a meeting](#)

SWMS to be reviewed

All subcontractors in consultation with principal contractor are to prepare Safe Work Method Statements in compliance with WH&S Legislation & principal contractor's Safety Management Plan prior to starting work at the workplace. If at any time a change in workplace conditions arise a review of that SWMS shall be considered by the supervisor

Sample form – [SWMS Checklist](#)

Materials and building component parts are safely handled

Refer to SOP – Removal and Storage of materials

Materials and components identified for salvaging are dealt with

The supervisor shall discuss with Stakeholders the ownership of salvaged materials. This information shall be disclosed to workers prior to commencement of work. When removed salvaged equipment shall be stored to prevent damage and made ready for transport as per instructions from Stakeholders

Site is protected and secured to prevent unauthorised access

Ensure access to site is restricted to those performing the task

Monitor and manage tasks and procedures.

[Refer to Training materials - Appendix 2 Hazard Identification](#)

Permits to Work

[Refer to Training materials – Appendix 2 Permits to work](#)

Hot Work

[Refer to Training materials - Appendix 2 Hot work](#)

[Permit to work](#)

Work safely at heights

[Refer to Training materials - Appendix 2 Work safely at heights](#)

[Permit to work](#)

VOC Selection and use of equipment and PPE

Ensure workers are trained and assessed as competent to use equipment & PPE

Sample form – [VOC](#)

Variation advice

Create a variation advice in response to the non-conformance toolbox talk feedback. Explain the new control and justify the reason for the variation. **Form sample** – [Variation](#)

End of day checklist

Just as a job site should be inspected prior to start up, so too should it be checked at the end of the day to ensure that:

- the site is Secure

- That tools and equipment are stowed away
- That all signage is still in its appropriate position
- That all control measures are in place to prevent collapse or destabilization
- That all rubbish has been removed to the designated waste zone
- That all walkways are clear of debris
- That all barricades or barriers are in place around trenches or penetrations
- That all chemicals are sealed and locked away in their designated area
- That all fire hazards have been eliminated

Form sample – [End of day checklist](#)

Housekeeping

Housekeeping includes housecleaning, that is, disposing of [rubbish](#), cleaning dirty surfaces, dusting and [vacuuming](#). It may also involve some outdoor chores, such as removing leaves from rain gutters, washing windows and sweeping doormats. The term housecleaning is often used also figuratively in politics and business, for the removal of unwanted personnel, methods or policies in an effort at reform or improvement.^[5]

Housekeeping is done to make the site look and smell better and to make it safer and easier to live in.

Removal of debris

Disposal of rubbish is an important aspect of Housekeeping. Plastic bags are designed and manufactured specifically for the collection of litter. Many are sized to fit common waste baskets and trash cans. Paper bags are made to carry aluminum cans, glass jars and other things, although most people use plastic bins for glass since it could break and tear through the bag. [Recycling](#) of some kinds of litter is possible.^[6]

Dusting



Some dusting tools

Over time [dust](#) accumulates on surfaces. As well as making the surfaces dirty, when dust is disturbed it can become suspended in the air, causing sneezing and breathing trouble. It can also transfer from furniture to clothing, making it unclean. Various tools have been invented for dust removal: [Feather and lamb's wool dusters](#), cotton and polyester dust cloths, furniture spray, disposable paper "dust cloths", dust mops for smooth floors and vacuum cleaners. Vacuum cleaners often have a variety of tools to enable them to remove dirt not just from carpets and rugs, but also from hard surfaces and upholstery.^[7] Dusting is very important in hospital environments.^[8]

Removal of dirt



Two women cleaning the floor

Examples of dirt or "soil" are [detritus](#) and common spills and stains in the home. Equipment used with a cleaner might include a bucket and sponge or a rag. A modern tool is the spray bottle, but the principle is the same.

Chemicals

Various cleaning products have been developed to help remove dust and dirt, for surface maintenance, and for disinfection.^[9] Products are available in powder, liquid or spray form. The basic ingredients determine the type of cleaning tasks for which they are suitable. Some are marketed as general-purpose cleaning materials, while others are targeted at specific cleaning tasks such as drain clearing, oven cleaning, lime scale removal and polishing furniture. Household cleaning products provide aesthetic and hygiene benefits, but may cause health risks.^[10] Safety Data Sheets are available from the manufacturers of chemicals you purchase or on the internet. [safety data sheet](#).^[11]

[Surfactants](#) lower the surface tension of water, allowing it to flow into smaller tiny cracks and crevices in soils, making removal easier. [Alkaline](#) chemicals break down known soils such as grease and mud. [Acids](#) break down soils such as lime scale, [soap scum](#), and stains of mustard, coffee, tea, and alcoholic beverages. Some [solvent](#)-based products are flammable and some can dissolve paint and varnish. [Disinfectants](#) stop smell and stains caused by bacteria.

When multiple chemicals are applied to the same surface without full removal of the earlier substance, the chemicals may interact. This interaction may reduce the efficiency of the chemicals applied (such as a change in [pH](#) value caused by mixing alkalis and acids) and in some cases may even emit toxic fumes. An example of this is the mixing of ammonia-based cleaners (or acid-based cleaners) and bleach.^[12] This causes the production of [chloramines](#) that volatilize (become gaseous), causing acute [inflammation](#) of the lungs (toxic pneumonitis), long-term respiratory damage, and potential death.^[13]

Residue from cleaning products and cleaning activity (dusting, vacuuming, sweeping) has been shown to worsen [indoor air quality](#) (IAQ) by redistributing [particulate matter](#) (dust, dirt, human skin cells, organic matter, animal [dander](#), particles from [combustion](#), fibers from insulation, [pollen](#), and [polycyclic aromatic hydrocarbons](#)) to which gaseous or liquid particles can be adsorbed. The concentration of such particulate matter and chemical [residual](#) will highest immediately after

cleaning, and will decrease over time depending upon levels of contaminants, air exchange rate, and other sources of chemical residual.^[12] Of most concern are the family of chemicals called VOCs such as [formaldehyde](#), [toluene](#), and [limonene](#).^[14]

[Volatile organic compounds](#) (VOCs) are released from many household cleaning products such as disinfectants, polishes, floor waxes, air-freshening sprays, all-purpose cleaning sprays, and glass cleaner. These products have been shown to emit irritating vapors.^{[9][15][16]} VOCs tend to evaporate and then to be inhaled into the lungs or [adsorbed](#) by dust, which can also be inhaled.^[9] Aerosolized (spray) cleaning products are important risk factors and may aggravate symptoms of adult [asthma](#),^[16] respiratory irritation,^[9] childhood asthma, wheeze, bronchitis, and allergy.^[15]

Other modes of exposure to potentially harmful household cleaning chemicals include absorption through the skin (dermis), accidental ingestion, and accidental splashing into the eyes. Products for the application and safe use of the chemicals are also available, such as nylon scrub sponges and [rubber gloves](#).^[17] It is up to consumers to keep themselves safe while using these chemicals. Reading and understanding the labels is important.

Chemicals used for cleaning toilets, sinks, and bathtubs can find their way into sewage water and can often not be effectively removed or filtered.

There is a growing consumer and governmental interest in [natural](#) cleaning products and [green cleaning](#) methods. The use of nontoxic household chemicals is growing as consumers become more informed about the health effects of many household chemicals, and municipalities are having to deal with the expensive disposal of [household hazardous waste](#) (HHW).^{[18][19]}

Tools

[Brooms](#) remove debris from floors and [dustpans](#) carry dust and debris swept into them, [buckets](#) hold cleaning and rinsing solutions, [vacuum cleaners](#) and [carpet sweepers](#) remove surface dust and debris, [chamois leather](#) and [squeegees](#) are used for window-cleaning, and [mops](#) are used for washing floors.^[20] To ensure safety, protective apparel including rubber [gloves](#), [face covers](#), and [protective eyewear](#) are also sometimes used when dealing with chemical cleaning products.^[21]^[citation needed]

Yard

A home's yard and exterior are sometimes subject to cleaning. Exterior cleaning also occurs for safety, upkeep and usefulness. It includes removal of paper litter and grass growing in sidewalk cracks.

Chapter 8- Finalising the project



Finalise activities

Plan handover of property.

Information relating to contract is reviewed to confirm timelines for completion and site handover specifications.

- Handover process is confirmed and scheduled with relevant stakeholders and required amendments to timeframes or handover specifications are negotiated and recorded.
- **Finalization tasks** are confirmed and scheduled, and **resources** required are assessed and arranged according to workplace and site requirements.
- Work health and safety (WHS) requirements are determined and applied to task planning according to safety plans and policies.
- Environmental requirements are identified for the project according to environmental plans and regulatory obligations.
- Team is briefed, and finalization tasks are allocated and confirmed as understood by team members according to workplace procedures.

Monitor quality and timeliness of job completion.

- Audit of property is conducted to determine condition of work site and surrounds before initiating demolition finalization tasks, and safe work method statements (SWMS) are adjusted in consultation with relevant personnel, as required.
- Scheduled tasks are started within required timeframes and progress is monitored to completion to ensure deadlines are met.
- Hazard control and regulatory compliance are monitored throughout the finalization process and team members are directed to use specific procedures or techniques, as necessary.
- Completed tasks are assessed against specifications; and discrepancies are noted and resolved or recorded in relevant documentation.
- Property is inspected and checked against finalization schedule and quality requirements; and discrepancies are identified and resolved or recorded in relevant documentation.

Conduct handover site inspection with stakeholders.

- Handover site inspection appointment is confirmed with property owner or authorised representatives and other relevant personnel, as required.
- Procedures and required documentation for handover site inspection are confirmed with stakeholders.
- Records relating to completed demolition work are reviewed and agreed variations to initial specifications are recorded or confirmed in completion documentation.
- Site safety inspection is conducted, and site safety induction arranged or delivered to stakeholders prior to handover site inspection.
- Sections of site are inspected according to handover site inspection schedule and signed off as complete; or discrepancies are discussed, and solutions negotiated and recorded.

Supervise site clean-up.

- Removal and storage or disposal of plant, tools, equipment materials and waste are monitored and directed to ensure compliance with workplace, safety and environmental requirements.
- Team members are debriefed and opportunities for learning identified and actioned as required.
- Project documentation is completed and processed according to workplace and project requirements.

Work area is cleared, and materials disposed of

Everyone is responsible for his or her own personal rubbish, food scraps, drink containers, newspapers and the like, which also must be placed in the bins provided.

Plant, tools and equipment are cleaned, checked, maintained and stored

Ensure that all plant and equipment is maintained, cleaned and stored according to the manufacturer's guidelines and site requirements.

Finalise work and complete handover documentation.

- Solutions to discrepancies discovered on handover site inspection are implemented according to negotiated schedule and monitored and checked for completion to required standard.
- Site clearance is supervised and checked to ensure all plant, tools, equipment, materials and waste are removed and ground prepared according to agreed standard.
- Final documentation is prepared and processed according to project and workplace requirements.
- Site is secured according to project and workplace requirements.

Handover checklist (Practical Completion)

Give the client copies of any outstanding documentation such as:

- certificates of inspection
- Reports, notices or other documentation issued by service providers (e.g. electricity, gas, telephone, water or sewerage).

It is recommended that you provide the client with all certificates of inspection (including where appropriate, the 'final' certificate) prior to receiving the final payment. This can also be a mandatory requirement of your contract, so it is important that you're aware of the contract conditions. **Form sample - [Handover checklist](#)**

Defects document

Complete this with the owner during handover inspection.

It must:

- list the minor defects and minor omissions that both you and the owner agree to
- state when you'll attend to the matters
- separately list minor defects or minor omissions that only the owner believes exist, and
- Be signed by the owner and yourself (or if you've signed it you need to make reasonable efforts to have the owner sign it).

Fixing items listed on the defects document

You need to fix any minor defects or omissions that you note at handover, within 6 months after completion of the work.

If there is any other defects discovered after that time, the owner should send you a written list. Keep copies of all correspondence for your records.

Practical completion notice

Prior to closing the project, the supervisor must complete a practical completion notice that notifies the client that the practical works are finished. It also sets down the agreed time frame from rectifications on any identified defects found during the handover checklist.

[WA Form](#)

[Vic Form](#)

Form sample – [Practical completion](#)

Meeting – Closing the project

The supervisor conducts a final meeting with the client. This meeting needs careful planning and preparation to ensure the quality and effectiveness of delivery. Regardless of whether the report is made to the entire company or only a department, management and representatives should receive feedback on the project including any outstanding contractual requirements.

The closing meeting is held to close the project in a conclusive and professional manner, to agree the dates for the completion of any remedial action required and to establish any subsequent work.

The meeting is chaired by the PC or officer for the PC and is conducted as follows:

- Thank the client for their attendance
- Give a brief outline of the objectives, scope and special requirements of the project
- For the benefits for any people not at the opening meeting, re-introduce the PC management team
- Request that questions be held over till the end of the meeting
- Discuss each section of the project
- Highlight the goals of the project and the successful milestones
- Raise any non-conformances that required notification and what remedial actions were implemented to rectify them
- Give an overall summary of the project based on the outcomes achieved
- Hand over any outstanding documentation, briefs, registers that the client will require for the completion of the project

Form sample – [Meeting record](#)

Meeting – Evaluation

Conduct a meeting with the contractors to review and evaluate your performance in managing the safety on the demolition site. Identify any weaknesses in your procedures and areas for improvement. Measure the outcomes against the project schedule.

Form sample – [Performance Appraisal](#)

- Were the Key Performance Indicators are achieved?
- Did the demolition teams perform as projected?
- Were the project milestones met?
- Were there any instances or aberrations in the process or policy that requires further scrutiny and review?

Appendix 1. – Establishing your business



You are now ready to establish a business to use the information contained so far, however, do not dash out as the expert in your field. Find a Mentor to guide you. Someone who has been successful that you relate well with and trust. Learn from them, express your appreciation for their help.

Where can I get help?

[Achieve Best Practice](#) can assist to set-up your business including

- **Company Start-up and registration**
- **Accounting systems**
- **Integrated Management Systems**
- **Policy & Procedures Manuals**
- **Safe Operating Procedures**
- **Project Management Plans**
- **SWMS**
- **Training**
- **Licensing**
- **Certification**
- **Business Mentoring**
- **Business Plan**

Research

Here are some sites to visit

[Starting a business guide](#)

[Steps for setting up your business](#)

[Starting a business checklist](#)

[ATO guide](#)

[ASIC register a Company](#)

[Small business grants](#)

[I want to start my own business](#)

[Achieve Best Practice in my Business](#)

It is critical that your business is set up correctly before you commence trading. If you fail to do this task your business will fail. You will create or obtain from someone else and edit the document to show your business name.

There is more to implementing a Management System than just buying the system. Staff must be consulted and trained, records entered, goals and targets set, clients polled for comment, subcontractors assessed and general review of your business. The Company must allocate resources adequate to achieve this process.

Business Plan.

A business plan is a formal statement of business goals, reasons they are attainable, and plans for reaching them. It may also contain background information about the organization or team attempting to reach those goals. Written business plans are often required to obtain a bank loan or other financing. [Wikipedia](#)

A Business Plan with financial projections for first year of trading is vital to business survival. You must identify all the costs associated with the business and project cash flow. This should be done in consultation with your accountant / business adviser.

Policy & Procedures Manual.

A policy & procedures manual identifies our Corporate policies and how we will do business to ensure we comply with various laws and our Policies. The **policies** you make define your firm's standards for decisions on personnel and organizational issues. Clearly defined **policies and procedures** help your company run more efficiently, and help you make fair decisions. ... The **policy manual** is a written expression of the rules governing the employer/Worker relationship

Compliance

To be the best you can in business is known as “Best Practice”. To attain this status you will need to establish good business practices which include:

- Financial management
- Safety Management
- Environmental Management
- Quality Management
- Human Resource Management
- Insurances
- Policies & Procedures
- Training

Video - [Compliance at a glance](#)

Integrated management systems

Ideally you will have an integrated management system currently which provides Policy & Procedures, Risk Assessments, SDS, forms and Safe Operating Procedures customizable for your business.

The approach to Risk Assessments is **not** a *generic* document without relevance to business activities; it is a universal business risk assessment tool for tasks, and plant and chemical use. You can customize the control measures according to your activities and see the resulting risk score to ensure activities can be safely undertaken or allow work to proceed under *ALARP* conditions.

Documents should be produced with client identification, rather than *generically tagged*. This shows ownership of the safety system.

Resourcing of the Management Systems

There is more to implementing a Management System than just buying the system. Staff must be consulted and trained, records entered, goals and targets set, clients polled for comment, subcontractors assessed and general review of your business. The Company must allocate resources adequate to achieve this process. A record of the resources provided should be items from your accounting program and a record kept

Company manuals and documents

Depending on your selection of modules, the system should allow creation of manuals that are company specific. Documents should include:

- Policy & Procedures Manuals
- Induction Booklet
- Worker Induction Booklet
- Work Health and Safety Management Plan (WHSMP)
- Safe Operating Procedures
- Risk Assessments
- Emergency Management Plans (this does not include the creation of evacuation diagrams)

Bullying and Harassment

These are not tolerated by Law and are Criminal offences which can impact on your business. You must have Policies and Procedures in place to prevent and manage the potential for Workplace violence.

Video - [Prevention & management of work violence](#)

Video - [Workplace violence and mental health](#)

Video - [Workplace bullying and mental health](#)

Video - [Bullying & harassment in Construction](#)

Quality Assurance

- Policy & procedures
- Defects & practical completion
- Drawings issued
- Extension of time
- Product tracking
- Projects
- Request for information
- Services on site
- Site diary
- Variations
- Inspection & test plans
- Contractor management

Quality Assurance tutorials

The following tutorials are prefixed by Ads, please use the "Skip ADS" button or subscribe

Video - [Introduction to Quality](#)

Video - [Quality Control](#)

Video - [Quality Assurance](#)

Video - [Lean production](#)

Video - [Stock control](#)

- Video – [Economies of scale](#)**
- Video – [Price skimming](#)**
- Video – [Improving cash flow](#)**
- Video – [Introduction to the balance sheet](#)**
- Video – [SWOT Analysis](#)**
- Video – [Span of control](#)**
- Video – [Change management](#)**
- Video – [Organisational culture](#)**
- Video – [Costs of poor quality](#)**

Action Plan - Quality Assurance

The following additional requirements are required to meet QA requirements.

Form Sample – [Quality Plan](#)

Customer focus

Refer to your manual on the tasks required here to achieve compliance

Purchasing

Refer to your manual on the tasks required here to achieve compliance

Production and service provision

Refer to your manual on the tasks required here to achieve compliance

Training

Train site supervisors in system use

Site supervisors shall be trained in

- the basics of QA including discussions on system manual contents
- use of forms on tablets and hard copy
- completion and submission of forms to administration
- the importance of providing feedback
- attending and recording meeting outcomes
- the importance of documentation
- the importance of asking questions when unsure
- the importance of methodical performance of the task

Train Administration staff in system use

Administration staff shall be trained in

- the basics of QA including discussions on system manual contents
- ensuring completion and submission of forms to administration
- the importance of providing feedback
- attending and recording meeting outcomes
- the importance of documentation
- the importance of asking questions when unsure
- the importance of methodical performance of the task
- verifying documents submitted are complete and accurate

Implementation of system

Refer to your manual on the tasks required here to achieve compliance

There is a series of Meetings to conduct

[Management Decision to proceed](#)

[Contractor](#)

[Worker Induction](#)

[SWMS](#)

[Safety Review](#)

[Review meeting outcomes](#)

[Management review](#)

Establish a folder for each project

Create an individual folder for each project and file all documentation. This provides the information required to create site specific documents for a project. The minimum requirements are “bolded topics”

Ensure documentation for each new project is established

- **Tender documents**
- Use “[Project set-up document](#)” to ensure appropriate documents are on-site
- **Plans & specifications entered in Drawings issued**
- **A copy of appropriate forms is available to site**

Defects & practical completion

This section provides you the ability to record practical completion of your projects. Make a record of all defects at handover and track their completion. Provide a copy to the client with a copy of the contract required “[Practical completion](#)”

Drawings issued

All drawings issued for a project shall be recorded. Notify contractors of new issues. File a copy of new documents and “Archive” old copies. Obtain an acknowledgement from each contractor

Extension of time

Record any [extensions of time](#) on the project, ensure accounts department is notified. Ensure the client authorizes the extension

Product tracking

All trackable materials shall be recorded in this folder on a per project basis. Identify by an appropriate location to ensure that you can find materials used. Ensure site drawings are marked up with material locations. Include make, model, and serial number and include a copy of all provided manufacturer’s or supplier certificates

Request for information

Record all [information requests](#) and be reminded of the actions required. Ensure all responses are filed in this folder

Services on site

Record all existing services and installed services to enable provision of “As constructed drawings” on completion. Make a record on your site plan of all services. Post a copy on the site Notice board

Site diary

Record day to day activities on site daily in your Site Diary and have information available live to Head office. This will provide documentation of site activities

Form sample – [Site diary](#)

Variations

Record any variations on the project ensure accounts department is notified. Record all variations and ensure appropriate authorisation is obtained. A scanned copy shall be filed here

Form sample - [Variation](#)

Inspection & test plans

Maintain quality reviews on site to ensure product quality meets the specification requirements. Determine the ITP documents required for each project based on the scope of works. Select the required set of documents and use the “Select and download a zip file of forms” function in the system. Issue the relevant forms to each contractor. The contractor will complete the document and submit to the site supervisor who will verify project status. This form will provide the basis for authorisation of payments and shall be attached to any invoice submitted for payment.

Form sample – [Quality plan](#)

Contractor Management

Maintain a list of all Sub-contractors, Request proof of sub-contractor compliance with Legislation. If the contractor does not have compliance, they should be referred to PQC Management Systems to obtain certification. Attach the certification and file/attach it to the sub-contractors file

Form sample – [Contractor accreditation / Information sheet](#)

The certification will verify:

- **ABN**
- **Licensing**
- **Insurance**
- **Safety Plan**
- **Worker training/competencies**

Contact all of your Sub-contractors or use information on file to complete the following:

- **Sub-contractor details**
- **Plant & Equipment**

Resources for Builders

Safety Management system, Quality Assurance & environmental Management - [ABP](#)

Quotation and project documentation - [Smartsheet](#)

Estimating software - [Speedy estimating](#)

Estimating software - [Databuild](#)

Audit

Audit Preparation

What is an Audit?

An Audit is an independent assessment by a person verifying that you are doing what the MANAGEMENT SYSTEMS system says you should be doing. The Audit process is about verifying that you are doing what is legally required of you by ensuring that you comply with the requirements of the Standard being certified.

Feedback To and From Staff

Part of the implementation process is consultation with Staff, including obtaining feedback and considering that feedback. You must also give feedback to your Staff on how well they are achieving compliance. Remember the compliance process is also about making your business Safer and more Productive. Record the feedback as part of the meeting process

Create an internal audit schedule

Refer to your manual on the task required here

Form sample – [Internal audit schedule](#)

Meeting – Site safety audit

The site inspection focuses on the implementation of risk controls used by contractors following the work health and safety (WHS) management plan assessment. The intent of the site inspection is to benchmark the safety practices observed on site against the criteria contained in the checklist. It is acceptable to review a representative sample of items and, based on the evidence that is available at the time, assess whether the undertaking conforms to the set criteria.

Form sample – [Audit preparation](#)

Video - [The Safety Inspection Process](#)

The site safety audit is an expansive and comprehensive exercise and should review, in its entirety or a sample of:

- Administrative processes
- Training
- Risk management
- Harmonisation
- Safety documentation / control measures and systems
- Work environment
- Amenities
- First aid facilities
- Risks directly associated with scope of activities (EG working at heights, falls etc)
- Demolition procedures and policies
- Welding and hot work
- Services
- Plant
- Noise

This audit is intended to meet the needs of a wide range of stakeholders, including:

- those responsible for developing risk management policy within their organization;
- those accountable for ensuring that risk is effectively managed within the organization or within a specific area, project or activity;
- those who need to evaluate an organization's effectiveness in managing risk; and
- Developers of standards, guides, procedures and codes of practice that, in whole or in part, set out how risk is to be managed within the specific context of these [documents](#).

Work improvement notice

Supervisors must be able to issue a work improvement notice on a non-conformance identified during the site safety audit. Supervisors may issue an improvement notice in any circumstance where they form a reasonable belief regarding a contravention unless some other appropriate action is considered by the inspector to achieve the desired outcome.

Form sample – [Work improvement notice](#)

Meeting – Review the non-conformance from the audit

In response to the site safety audit non-conformance conduct a toolbox talk, addressing the non-conformance and discussing the reasons, oversights and seek feedback on how to avoid the same situation into the future. **Form sample – [meeting record](#)**

Review the standard procedures to see if they are still relevant to the scope of work and that the performance criteria are still effective in achieving an optimal outcome.

Protecting yourself from Safe Work Liability

As a PCBU (the new name for an Employer) the maximum liability under the new Harmonised Safety legislation is \$3 million that is a huge potential liability that will wipe out most small business. You can no longer afford to shrug your shoulders or turn a blind eye. Then there is the “No win no fee” brigade who follow if you are lucky enough to escape the long arm of Worksafe.

There must be a simple way to make your business safe from these woes. Unfortunately there is no Guarantee, however you can minimise your exposure by implementing a Safety Management System. When I speak to the average tradie about systems their response is “I have a SWMS that will do”. A Safety Management System is a lot more, it is a documented way to do business and more importantly it must be written to suit your business. There are many off the shelf systems, but they are so generic with little or no ability for change or are provided to you on a disc with the assumption that you can edit it to suit. Great but do you know what changes are necessary?

According to Wikipedia: A **Safety management system** (SMS) is a term used to refer to a comprehensive business **management system** designed to manage **safety** elements in the workplace. Key words are “comprehensive” and “manage”. You need to find a Safety professional who can assist you to economically provide a safety management system that will enhance your business, provide safe methods of work but also allow you to earn a dollar or two without a large percentage of your earnings going on “Safety management”

What does a system really have to do? Remember according to legislation we must comply with the Australian Standard 4801 and the harmonised National legislation (in most states), but we do not need a system that imposes upon us so many restrictions that work is impractical. We only need to establish systems that are appropriate for the size and nature of our business and for the work we

undertake. We do not need processes for a transport company if we work from home and drive a Ute.

To view the requirements of a Safety Management System audit for compliance take a look at the audit tool (questionnaire) that I am required to review when auditing your business for compliance. It can be rather daunting for the uninitiated. The Queensland Government Worksafe (Similar in all states) audit tool can be found at

What do I need in a Safety Management System?

1. Access

Log on to your system or have a manual system, if you are daunted by computers and become familiar with the features.

2. Setting up your system

The system needs to be customised to best meet your needs, your consultant can set-up your preferences to ensure you are only seeing the features relevant to you.

3. Create a Work Health & Safety Management Plan

Work with your consultant to create a plan that meets your needs.

4. Safe Work Method Statement / Permits to Work

Have available templates for Safe Work Method Statements and Permits to Work to ensure a readily understood process by the workers.

5. Risk Management

Allocate duties for Risk Assessment and Safe Operating Procedures.

6. Consultation

Conduct Work Health & Safety meetings to allow staff to have input to the process and ensure everyone understands why the changes need to be made. In these meetings nominate the Health & Safety Representative and the Safety Committee

7. General Records

Input records for First Aid, Plant, Equipment, Vehicles, Insurance, Lifting Equipment, Keys, etc.

8. Risk Management

Schedule inspections, Identify and track non- conformance, establish a hazard register and permits to work.

9. Human Resources

Track health surveillance records, drugs & alcohol (optional), staff expectations (optional), performance appraisals (optional), training needs, incident management, and online training.

10. Manage contractors

Track contractor compliance with legislation, certification documents and inductions or training

Training :- Times, “They are changin”

Bob Dylan could never have imagined the relevance that those immortal words would carry into the 21st century.

The old paradigms in VET training are changing.

Traditional trainers and traditional classrooms have been redefined to accommodate technology, geography, literacy and numeracy.

The classroom is no longer four walls, one floor and a ceiling – it’s now a digital superhighway that spans the country; even the globe!

The ‘form’ of a trainer is no longer a man or woman that stands at the front of a room writing on a whiteboard.

It runs 24 hrs per day, seven day per week! It doesn’t take leave, recognise public holidays, or get sick. It can speak every language; work at the speed of the individual, without sacrificing the

progress of the many to do so. It can access the latest information instantly. It can play music, videos, conduct assessments and record audio – all in real time – and it's happening right NOW. RTO's can-not afford to be complacent. They must be able to shift quickly, respond to market demand and regulatory requirements. They can't afford to rely on government funding anymore. Costs must be managed more effectively than ever before because the times are changing! Perhaps Bill Clinton summed it up modernity best when he said:

The price of doing the same old thing is far higher than the price of change.

Appendix 2. - Learner materials

Read and Interpret Plans and Job Specifications

Basic Calculations

When working on a construction site, it is good to know some basic calculations.

Area

$$\text{Area} = \text{Length (L)} \times \text{Width (W)}$$

For example:

A section 4m wide and 20m long would have the following area:

$$\begin{aligned}\text{Area} &= 4\text{m} \times 20\text{m} \\ &= 80\text{m}^2\end{aligned}$$

$$\begin{aligned}\text{Length} &= \text{Area} \div \text{Width (W)} \\ \text{Width} &= \text{Area} \div \text{Length (L)}\end{aligned}$$

For example:

An area of 50m² with a width of 5m can be worked out this way:

$$\begin{aligned}\text{Length} &= 50\text{m}^2 \div 5\text{m} \\ &= 10\text{m}\end{aligned}$$

Volume

$$\text{Volume} = \text{Length (L)} \times \text{Width (W)} \times \text{Depth (D)}$$

For example:

A trench 20m long, 4m wide and 0.5m deep would be calculated in the following manner:

$$\begin{aligned}\text{Volume} &= 20\text{m} \times 4\text{m} \times 0.5\text{m} \\ &= 40\text{m}^3\end{aligned}$$

Grade

Grade calculations are used to determine how much slope is present or is needed to achieve the specifications. To do this you will need to know the rise and the run of the land. The rise is the distance the road or area raises over a designated distance. The run is the designated distance. The formula is:

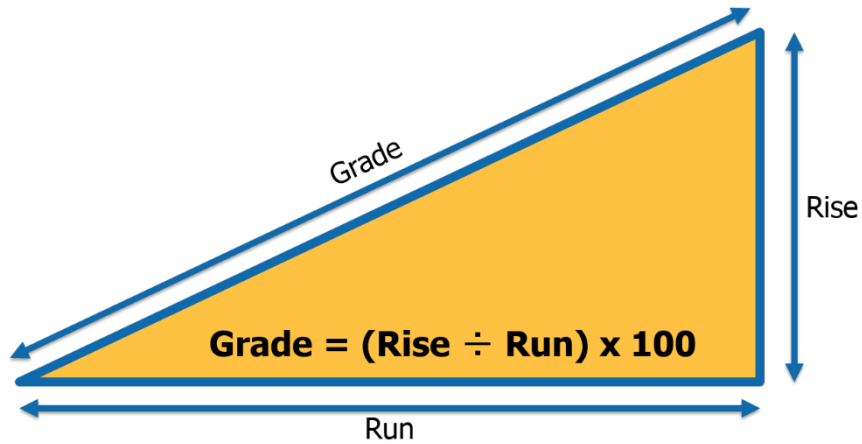

$$\text{Grade} = (\text{Rise} \div \text{Run}) \times 100$$

For example:

If the rise is 0.5m and the run is 10m then the grade would be calculated as shown here:

$$\begin{aligned} \text{Grade} &= (0.5\text{m} \div 10\text{m}) \times 100 \\ &= (0.05) \times 100 \\ &= 5\% \end{aligned}$$

$$\text{Grade} = \frac{\text{Rise}}{\text{Run}} : \frac{\text{Run}}{\text{Rise}}$$

For example:

If the rise is 0.5m and the run is 10m then the ratio of the grade would be calculated as shown here:

$$\begin{aligned} \text{Grade} &= \frac{0.5}{10} : \frac{10}{0.5} \\ &= 1 : 20 \end{aligned}$$

So written as a ratio the grade is **1:20**.

Plans, Drawings and Sketches

Project plans and drawings give you an overview of the site, for example:

- Location of the site and earthworks in relation to the surrounding area.
- The position of structures, roads, access areas.
- Layout of drainage lines.
- Foundation details and landscaping features.
- Depending on the project, drawings may be very detailed, or they could be simple sketches.
- You should learn about the conventions and symbols used in the plans and drawings so you can understand what the information means.

Types of Plans

A site plan is a vertical plan of a building site or allotment. Site plans can be drawn at various scales (e.g. 1:200) and they contain features such as:

A datum (a reference point to which all measurements refer).	Features such as trees, rocks and existing structures.
A north point for site orientation.	The shape of the site.
Plan page number.	Dimensions.
Date the plans were drawn.	Elevations.
Scales used.	Services (e.g. gas, water).
Client's name.	Existing buildings and structures.
Project address.	Driveways, roads, paths and drainage.
Contours (either imposed on the plan or noted separately).	Distance from the boundaries, walls and buildings.
The reduced level (the level at a construction site after excavation in relation to a given datum).	Name and reference numbers of document owner (draftsperson/engineer).

The main types of plans that you may need to refer to are:

Plan Type	Description
Locality Plans	A locality plan shows the location of the worksite.
Cross-Sectional Plans	These plans show a cut away view of an area to illustrate depth and material details.
Longitudinal Plans	These plans are used to illustrate current and planned angles and grades of surfaces and roads.
Structural Details and Specifications	These plans and drawings are used to outline the structural requirements of the job, for example bridges and overpasses.

All of these plans provide illustrations, dimensions and project details that will help you to plan for the work ahead.

Key Functions of Drawings

Plans and drawings are used to clarify detailed aspects of the tasks. It is necessary that all members of a work team are able to understand drawings and read the plans for the work tasks.

Some functions of the drawings may include:

- Identifying the location of the project.
- Identifying surrounding structures or properties.
- Identifying general characteristics of the project.
- Highlighting landscaping features.
- Showing drainage lines.
- Showing service or utility locations.
- Identifying formation types.
- Showing foundation details.
- Defining the types of materials or products to be used.
- Defining emergency contact and action details.

Plans or drawings will also detail highly specific information concerning particular aspects of the project such as:

- Australian Standards and industry requirements.
- Compatibility requirements – all aspects of the plan should be compatible with other plans for the site.
- Material compatibility.
- Schedule of actions to ensure compatibility between various aspects of the project.
- Laboratory testing.
- Drawing Conventions

Every construction drawing or plan will follow a set of conventions. Drawing conventions are the rules or standards that apply to ensure that drawings are readable and accurate.

Common conventions may include:

- Use of dimensions and elevations.
- Use of lines or sections and projections.
- Use of orientation.
- The scale applicable.
- Specific lettering and numbering.
- How materials and objects will be represented graphically.
- Relative size and shape, landscape features.
- Use of symbols.

The conventions used are usually similar across civil projects with only minor differences in organisational style and terminology. Always check with a supervisor if you are uncertain.

Aspect in Drawings

The aspect or view of the drawing or illustration may include:

Side View	Looking at the object or detail from a side-on perspective.
Plan or Longitudinal View	This is also called an overhead view where the object is viewed from above.
Cross-Section or Profile	This is where the object is viewed from a "slice through" perspective.
Crossfall	This is used in road, bridge and drainage construction and shows the degree of fall from a given point. This then shows water direction and camber on the surfaces.

Features of Plans and Elevations

- Plans include front, rear and both side elevations and are drawn to scale.
- Elevations are a non-perspective view of the construction design. They are drawn to scale so that measurements can be taken for any aspect necessary.
- The elevations specify ridge heights, the positioning of the final fall of the land, exterior finishes and other details that are necessary to complete the picture.

It is important to understand all features of plans and elevations including:

Direction	Indicates the alignment or orientation of any position on the plan with respect to any other position. Usually indicated on the plan as "N" for north, for example.
Scale	Scale is a way of representing a large area on a small sheet of paper and showing proportion at the same time. The plan will be titled with the scale noted. Some plans will be noted as N.T.S (Not To Scale).
Contours	Refer to the lay of the land, e.g. slopes, banks, depressions, hills, etc. Contour lines drawn on a map indicate connecting points of equal height on the ground.

If there is any doubt as to the validity or currency of the plans, specifications or drawings, you must check before using the information.

Key Features of Plans

Symbols and Abbreviations

- Symbols and abbreviations on plans and specifications are used to detail characteristics of the plans and convey information to the person reading them.
- The symbols and abbreviations used can change depending on the type of civil construction being undertaken and the organizational requirements.
- Symbols and abbreviations will appear on the drawing and will be detailed in the legend for the plan or drawing.
- It is essential that you are able to recognise the symbols and abbreviations used when interpreting or using plans and specifications.
- If you are not sure, talk to the document owner and clarify exactly what the plans require you to do.

Notes

- Notes are commonly found on plans and specifications to explain or detail specific elements on the drawing.
- Notes may include instructions on materials, instructions for interpreting the plan or guidelines that will help you to complete the job.

Legend

- To ensure that civil construction plans and specifications can be interpreted correctly, a legend is used to explain all the symbols and abbreviations that have been used.
- The legend will be clearly displayed with its title, usually in a corner of the drawing sheet or where appropriate, sometimes it appears on multiple pages or sheets.
- It may appear in colour or plain text, depending on the design of the drawings.

Some plans and drawings may include other features of the site such as existing vegetation or surface areas of mud or sand.

- Other buildings may be shown along with tanks, landmark objects or built-up areas.
- Drawings may also show the sections of land subject to inundation, or roads under construction.
- These features will all be indicated by a symbol in the legend along with its corresponding meaning.

Scale

Plans are usually "scale drawings", meaning that the plans are drawn at a specific ratio relative to the actual size of the place or object.

Commonly used scale ratios are 1:5, 1:10, 1:20, 1:50, 1:100, 1:200, 1:500, 1:1000, 1:2000 and 1:5000. The plan should identify the mode of measurement being used (e.g. millimetres). It is important to keep scale in mind as you examine the plans.

Title Panel

The title panel is usually located on the front cover of a set of documents or on the bottom of the plan/specification drawing.

The title panel details information such as:

- The project.
- The purpose/type of drawing.
- The scale used.
- Details of any revisions or amendments.
- The date on which it was issued.
- The document owner and contact details.

Make sure you always check the title panel to verify the latest amendments have been made. This will ensure you are using the most up to date version of the plans and drawings.

The plans and specifications should never be approved for construction if they are in draft or review format. This ensures that the most current and up to date drawings are in use for the project.

Checking Plans for Amendments

It is helpful to recognise the changes between versions and understand the changes that have occurred. This will ensure you are completing tasks following the most up-to-date plans available.

Amendments to plans and specifications can include changes to:

- Materials and quality of work.
- Quality assurance.
- Nominated sub-contractors.
- Provision of site access/facilities.
- Details relating to performance including:
 - Standards of work.
 - Tolerances.
 - Material types.
 - Characteristics.
 - Treatments and finishes.
- Specifications and requirements may change due to:
 - Design or location changes.
 - Survey requirements.
 - Material qualities, quantities and supply.
 - Organisational requirements.
 - Client or customer requirements.

Other related factors.

It is essential that you check for any amendments to the specifications before commencing a task or project.

Amendment Registers / Drawing Register

Specifications could change throughout the duration of a project. It is important to check the required specifications for any amendments regularly. This ensures that you are working following the most current information available.

Amendment registers allow for records to be kept which show when changes have been made to the specifications or plans.

To ensure that all specifications are current, refer again to the title panel of the plans, drawings or notes.

If you have any doubt about the currency of the drawings speak with the document owner or your supervisor.

Form sample – [Document register](#)

Identify Key Features of the Site

You will need to gain access to the site to check the plans against the actual area and identify the key features for the project. Make sure you have permission to access the site and wear any personal protective equipment (PPE) required for entry. Keep to safe areas away from machines and equipment and make sure other personnel responsible for the site are aware you are there, what you are doing and how long you will be.

Once you have gained access to the site it is necessary to identify its key features. The site plan should be used to assist you to locate the features of the site that are relevant to your project. Key features of the site commonly found in site plans may include:

Datum

You may be required to identify the relevant datum for the site. This is a fixed point from which measurements are made.

Type of Product or Service

The type of product or service being constructed, used, designed or worked with will need to be identified as either part of another process or structure, or as a stand-alone activity.

Quantities

Using the site plan assists you in recognising the quantities of materials required or currently on site.

Form sample – [Bill of quantities](#)

Characteristics of the Site

- The location and structural features such as:
- Underground and above ground services.
- Buildings.
- Fences.
- Sheds.
- Topography including:
- Contours.
- River or creek beds.
- Slope of the land.
- Type of work being performed.
- Clearance zones.
- Environmental requirements.
- Safety issues.
- Client requirements.
- Task requirements.

Logistics in conjunction with the site features.

Sizes

Proposed sizes or dimensions of the construction activity or task. This may also include vehicle movements, turning areas, and access and egress points. The size of the work areas may correspond to the quantity or supply of raw materials.

Surfaces and Compatibility

- It is essential that you identify the types of surfaces that are to be worked on and around. By doing this you can assess their compatibility for the task and identify the equipment needed for achieving project quality requirements.
- Contingency plans may need to be developed for surfaces that may prove difficult or hazardous.

Location

The location of the site can assist in determining a number of important factors relating to the project. This may include:

- The types of transport and machinery required.
- Accessibility to the site.
- Resources available at the location.
- Resources required.

- The number of personnel/workers required and whether sub-contractors will need to be used.

Services and Utilities

It is very important that you know where any services and utilities are located on site. This will help to avoid damaging them during excavation or earthworks. You also need to make sure you know who owns or supplies the services and utilities on site. You may need to contact them during the project when working near or around services.

Your site plan will assist you to determine the key features of the site, so that the project can be conducted safely and effectively.

Orientation of the Plan with the Site

- When working with site plans, you need to orient (line up) the plan with the site. This is done so you can identify where you are in relation to the features around you.
- When orienting site plans you can use the north marker to align to the site.
- By convention, most civil construction plans are labelled from south to north, and from east to west, but you should always check if you are not sure.
- Using landmarks, landforms or buildings can assist you to orient yourself with the drawings.
- You can also use site features such as watercourses, basins, rivers, and bridges, as well as following the contour or slope changes.
- Orienting yourself with the site plan helps you to recognise if there are discrepancies (differences) between the plan and the actual environment.
- If there is a clear discrepancy between the drawing and the environment you are in, you will need to confirm you have the correct plan, and that the plans you are working with are the latest version.
- If discrepancies still exist in the latest version of the plans speak with your supervisor. Do not continue with the tasks until the discrepancy has been reported and you have been given the go ahead by your supervisor.

You may need to provide information about how the plans and site do not match or direct other personnel to areas in question.

- Identify Job Specifications
- Job specifications describe what needs to be done on a worksite to successfully complete a civil construction project. They may include:
 - Legislative, organisation and site requirements and procedures.
 - A completion date for the project.
 - Work requiring specific licenses such as demolition, excavation, and electrical or plumbing work.
 - Material and labour costs.
 - Worksite instructions.
 - Insurance information.
 - Protection of adjoining sites or buildings.
 - Protection and security of worksite when left unattended.

Materials and quality of work

– this includes the uses and amounts of different materials and components.

- Quality assurance.
- Nominated sub-contractors.
- Provision of site access/facilities.

- Details relating to the completed work including:
- Standards of work.
- Tolerances.

Refer to Quality Plan

Material types and characteristics.

Treatments and finishes.

Job specifications can be identified when looking at the project drawings, notes and descriptions. It is important that you are able to identify these specifications prior to commencing a project or task.

Key Features of Job Specifications

Specifications common to the civil construction industry may include:

Specifications	Description
Materials and Quality of Work	This includes testing, sampling, finished tolerances, and material properties.
Quality Assurance Requirements	Quality assurance requirements may be organisational, job or client specific, and may have to comply with Australian Standards or relevant codes of practice.
Nominated Sub-Contractors	Often organisations prefer to deal with particular sub-contractors to perform specific work. Sub-contractors who are not on the suitability list may need to provide other information or details of previous work before they can be considered, depending on the organisational requirements.
Provision of Site Access and Facilities	Some projects require specific facilities to be provided for effective management of the site including provision for contract or client representatives, wet and dry weather access points, meeting rooms, toilets, meal rooms, accommodation or other staff requirements.

Identify Standards of Work, Finishes and Tolerances

All standards of work finishes, and tolerances can be identified from the job specifications.

Standards of Work

Knowledge of the required standards of work will ensure that you carry out all tasks and activities in accordance with company policies and relevant legislation.

Standards of work as outlined in the job specifications include:

- Achievement targets – outlining the required or estimated productivity objectives.
- Environmental requirements.
- Quality requirements – dimensions and tolerances of the tasks, material standards, documentation requirements, project specifications, client standards.

Australian Standards.

It is essential that you identify these standards so that you can apply them in carrying out your work according to site plans and procedures. Speak with your supervisor or site quality officer if you are having problems identifying the requirements.

Finishes

- This term refers to the final surface of a material or area. Some materials may require specific treatments such as lime stabilizing, acid sulphate soil management or drainage layers.
- It is important that the correct finish is achieved at each stage of a civil construction project to prepare a foundation for the next stage of the work or to complete the project to specifications and quality requirements.
- Make sure you confirm the required finish for the task before you start and select the right equipment and techniques to achieve it.

Tolerances

- Tolerances are the allowable variations from a target, measurement, material characteristic or performance level. Quality requirements may describe tolerances as a percentage or ratio.
- You need to be aware of the tolerances while work is being completed. Check your work regularly to make sure you will be able to achieve the right outcome.
- If the completed work does not match the plans and specifications and is not within the allowable tolerances it will need to be reassessed and may need to be redone.
- Identify Material Attributes
- It is important to identify the properties of civil construction materials in order to understand how they perform or should be handled during the construction process.

Material attributes detailed in the job specifications will include:

- Construction requirements.
- Typical material defects.
- Treatments and finishes.
- Embodied energy of materials.
- Principles of heat, light and sound in building design.
- Interaction of different materials.
- Selection of environmentally sustainable design and construction materials.

Referring to the job specifications for the identification of material attributes will ensure that the appropriate materials are selected. They can then be used in accordance with project quality and site safety requirements. Job specifications may also include the disposal of contaminated materials.

Hazard Identification

Identify sources of information

Using reviews, tools and techniques to source information from others can assist you in identifying possible risk or hazards in the workplace. To narrow down a hazard or risk and to identify possible causes of a problem you can source other organisation data such as WHS information and data.

Video - [H&S - Hazard-ID](#)

Video - [H&S - Hazard-Identification](#)

Sources of WHS information and data may include:

- Audits
- Employer groups
- First Aid Records
- Hazard, incident and investigation reports
- Investigations can be raised
- Legislation, standards, manufacturers' manuals and specifications available at the workplace
- Manufacturer's manuals
- Minutes of meetings from incident investigations
- SDS'S and registers

Obtain information to determine workplace risks and risk controls

Research is an important part of any investigation into a WHS hazard and its associated risks. Failure to systematically identify what you are researching could mean that you will not be able to identify what information that you need to gather. If you have trouble with defining what information you are required to gather, consult with personnel that work in the area in which the information will be gathered.

Video - [Supervisors - Finding things in legislation](#)

Once you are clear on your research, you need to determine what information will provide you with the ability to identify the best way in which to minimise or eliminate the risk.

You may:

- Consult with other duty holders that will be impacted by the introduction of the equipment
- Clarify priority requirements with management and the personnel that the equipment is being purchased for.
- Determine whether there are any other options open and consult with appropriate personnel to determine if these options are appropriate. Do not just consult with one party. There are times in which your team members may use your research as a platform to get their point across. Confirm that the option should be considered by consulting with management. The idea may have already been considered and rejected. Do not waste your time researching and gathering information that does not assist you in making the appropriate recommendation/s.

Video - [H&S - Executive Officers DUTIES](#)

Collect information

Information as you now know can be gathered both internally and externally from the organisation. The information that you gather should support your recommendations and the recommendations that you have gathered from your team. Remember to make sure that the information is supported and from a reliable source.

Record your findings

If you have never written a report or recorded your findings, you should consider following the steps outlined below, which are:

- Clarify purpose and expectations
- Decide on appropriate report structure
- Gather information to support your case
- Circulate the report

Once you have consulted with staff and included their feedback in the report, you should present the report or information to the appropriate personnel.

Workplace inspections are events that are planned as a pro-active way in which to identify hazards before they can develop into an injury or illness. There are no rules as to who can do a workplace inspection; however, it is recommended that the person who performs the inspection has experience in the work area. This person should be either a supervisor for that area or the Health and safety representative or safety officer.

As part of the harmonisation of work health and safety, it is important that whoever performs the inspection consults with team members in the area. One of the goals of the harmonisation program is to foster a co-operative, consultative relationship between duty holders and the persons who they owe duties and their representatives.

Checklists can be used during the inspection to identify hazards. Checklists can help you identify the area of concern. For example, you may need to check whether workplace changes that have been implemented have ensured that the goals set have been met.

Your organisation may have one type of checklist, or a series of checklists that are separate for each area, especially when job roles, equipment and plant are different. It is important to make sure that you use the correct checklist. This means that you should make sure that you are familiar with the location of the appropriate checklists on your organisations data base. If you do not have access to the data base and do not have a copy of the checklist, make sure that you obtain a copy of the appropriate checklist from the appropriate member of your team.

Contribute to compliance and workplace requirements

A hazard is something that can cause harm in the workplace and a risk arises from the harm caused by the hazards, how serious the harm can be and the likelihood of it happening. When assessing risk it is important to review the information that is current. It is not wise to always assume that a risk occurs because processes are incorrect in the performing of the task that could cause the hazard.

Video - [H&S - Help lead the way with Zero Harm](#)

Form sample – [Risk Assessment](#)

A risk assessment should be carried out when:

- There is uncertainty about how a hazard may result in injury or illness

- The work activity involves a number of different hazards and there is an understanding about the hazards and how they interact to form greater hazards
- Changes in the workplace that may impact on the effectiveness of control measures

Risk assessments should not be necessary when:

- Legislation requires that specific hazards are controlled in a special way
- A code of practice or other guidance sets out the control measures applicable to your situation; and
- There are well-known and effective controls used in your industry and that they are suited to the purposes set out in the workplace. These controls can be simply implemented.

As part of maintaining a systematic approach to WHS Management, it is essential that the level of risk and organisational procedure will impact on the way in which hazards are prioritised. Hazards and associated risks are usually defined by their level of:

Harm the hazard can cause

Video - [H&S - 10 Commandments](#)

Consultation with other stakeholders and key personnel will assist an organisation in determining the order in which a hazard can be resolved.

The level of harm that workers will be exposed to; will usually place a high priority in the consultation process.

Availability of resources relates to the amount of human resources are available to execute the change.

Organisations have different ways in which to prioritise the hazards and hazardous jobs and how they are managed. Hazards should be assigned the highest form of potential loss or injury when:

- There is a likelihood that people will be exposed to the risk, the level of exposure and the amount; and
- The potential consequences of being exposed to the hazard, which relates to how serious an injury will arise when people are exposed to the risk.

A risk assessment must be performed when an activity is considered to be a high risk under WHS Regulations. All hazards have the ability to cause harm ranging from minor to serious injury and in some cases death.

Risks should be assessed using a risk assessment. It is important that you:

- Consult with stakeholders
- Remember the research findings that you have found.

When performing a risk assessment, it is essential that you consider how severe the harm can be to workers or those exposed to the risk by asking the following questions:

- What type of harm could occur? – How severe is the harm? Could it cause death serious injuries
- What factors could influence the severity of harm that occurs? = External or internal factors, whether the harm is immediate or gradual
- Could one failure lead to other failures?
- Could one event escalate into a serious event with more serious consequences?

It is also important to consider what type of harm a hazard may cause. One incident for example may lead to a series of problems. If one or more event can be stopped or changed then a risk may be eliminated or reduced. It is important in this instance to identify where the problem started and then consider the impact in each step of the process.

When assessing the harm that a hazard can cause, consider:

- The effectiveness of the control issue
- How work can be performed rather than relying on written manuals and procedures (Using the consultation process here can assist greatly in controlling harm)
- The situation and how they are normally meant to occur.

Identify duty holders and their range of duties

All duty holders must do everything that is “reasonably practicable” to protect the work health and safety of everyone at the workplace. This duty of care falls on all:

- PCBU
- Managers
- Supervisors
- Workers
- HSR

The aim of regulations is to minimise risk of injury or illness at the workplace. The management and control of risk in the control of hazards and risks in the workplace and provide them opportunities to contribute and participate in the process. The Work Health and Safety Consultation, Cooperation and Coordination Code of Practice for example provides for workers to take a more proactive action in the decision-making process through consultation. The more that workers and others participate and contribute to work health and safety, the more informed their decisions shall be.

Duty holders under the Common Law duty of care need to prove to the satisfaction of the court that the actions that they have taken to protect others from risk are reasonable and practicable. Duty holders need to clearly know what their duty is, what the implications are for each group and what happens if they do not comply.

Video – [H&S - Consultation.](#)

Worker duties

As a Worker, you have a legal obligation to recognise, document and report hazards to personnel. Now let us look at the sections covered in these performance criteria and explain in detail how each section impacts on you and your legal obligations for failure to comply with your duty of care.

Under the WHS/WHS Act, if you are a worker or other person you have a legal responsibility to:

- Their workplace safe for themselves and others
- Comply with reasonable instruction; and
- Co-operate with any reasonable policy or procedure of the PCBU.

A worker may include a person who carries out work in any capacity, including work as:

- A Worker
- A contractor or subcontractor
- A Worker of a contractor or sub-contractor
- A Worker of a labour hire company assigned to work
- An outworker
- An apprentice or trainee
- A student gaining work experience
- A volunteer

- A person of a prescribed task
- A police officer (when on duty and performing the tasks of a police officer)
- The person conducting the business or undertaking if the individual carries out work in that business or undertaking.

As a worker, under the WHS Regulations, you must manage a hazard that you have identified by either:

- Eliminate the risk or
- Minimize the risk to the health and safety of workers and others within your work environment.

However, as a worker you may not be found guilty, if it can be established that your employer did not provide you with adequate information, training and instruction according to the nature of your job and the risks associated with the job.

Contribute to workplace hazard identification

It is important that every day that you work, you are always on the lookout for any hazardous situations. Organisations will have procedures in place to document reporting on accidents, incidents and near misses. This should be part of the continuous improvement process to ensure that companies are working towards making the processes better at all times, and that they are maintaining the level of commitment they need to make the workplace a safe and healthy one for its Workers.

An effective continuous improvement process will allow everyone to get involved, thereby giving staff and managers a chance to take ownership and responsibility for the continual improvement within the organisation. This is particularly important when it comes to health and safety in the workplace, as this should be an area that is constantly being monitored and improved in all areas.

Some of the ways in which they can be advised of hazards in the workplace include:

- Company meetings
- Emails
- Blogs
- Newsletters
- Teleconferences

Video - [H&S - Code of conduct](#)

Managers need to be accountable for the identification of potential hazards.

Some of the ways in which they can do this include:

- General Observations
- Inspections
- Reports from other staff members
- Newsletters
- Surveys and Questionnaires

Managers are responsible for the following in relation to identifying potential hazards in the workplace;

Accurate reports should always be kept in relation to accidents, incidents and even near misses as part of the continuous improvement process.

Staff members should all be aware of the relevant policies and procedures and expectations in relation to the reporting of these issues, and what follow up action is required from them from a legal perspective.

Video - [H&S - Integrated MS](#)

Apply knowledge

To understand your legal requirements of risk Identification, control and resolution consult the How to Manage Work Health and Safety Risks Code of Practice, which can be found in any of the regulator websites for your State/Territory. The aim of this resource and the resources listed above is to provide you with tools that you may use to assist you in the performance of your duties. You may also find that some of these tools are a normal part of your organisations Work Health and Safety Procedures.

Video - [H&S - Introduction](#)

Under the WHS Act:

As far as “reasonably practicable” in regard to WHS Hazard Identification, you should weigh up all options in regard to work health and safety by:

- Ensuring that you minimize or eliminate the chance of a risk or hazard arising
- That you determine the level of harm that may occur from the hazard or risk
- What each party that contributes to the process knows about eliminating or controlling the risk;
- The ways available to minimize or eliminate the risk; and
- The costs associated with the minimizing or elimination of the risk.
- These options will be considered to determine whether you took the appropriate action in consideration of the procedures and controls (such as budgetary controls) put in place when you implemented steps to minimize or eliminate the risk.

Duty of care. In working within an organisation, you are required to ensure that the health and safety of others is not placed at risk. As part of the responsibility of staff, any risk identified in the workplace must be reported to the organisation. Your organisation will have policies and procedures in place, usually in the form of an accident/incident form.

All incidents and accidents should be reported to the State/Territory regulator.

Video - [Supervisors - Accident investigation-1](#)

Video - [Supervisors - Accident investigation-2](#)

Video - [Supervisors - Accident investigation-3](#)

Video - [Supervisors - Accident investigation-4](#)

Video - [Supervisors - complete an incident review](#)

When a hazard is identified you may be required to use hazard identification tools, techniques, processes and methods may include:

- Analysis of injury and claims statistics
- Audits
- Checklists for hazard identification
- Consultation with workers, clients or other users
- Interviews
- Investigations
- Job safety analyses
- Safety data sheets (SDS)
- Monitoring and measurement
- Observation

- Review of past incidents, incident and hazard reports, hazardous substances and dangerous goods registers, plant and maintenance records
- Review of research and industry literature
- Review of technical standards and other information sources
- Simulations
- Timelines of actions and events
- Use of incident models
- Workplace processes such as 'walk through', surveys and inspections

Apply techniques, tools and processes

Definitions

Hazard means a situation or thing that has the potential to harm a person. Hazards at work may include noisy machinery, a moving forklift, chemicals, electricity, working at heights, a repetitive job, bullying and violence at the workplace.

Risk is the possibility that harm (death, injury or illness) might occur when exposed to a hazard. To understand what a hazard or risk is you need to identify the type of hazard your workers are exposed to. All hazards have the potential to harm workers and personnel in terms of injury, illness and to property, the environment or a number of these factors. Once a hazard is identified it is essential to identify the different types of hazards so that you can apply the appropriate techniques, tools and/or processes to address the hazard.

It is important to know the appropriate documentation to complete for each assessment and to ensure that you have access to this documentation. Most organisations used to have one type of risk assessment. However, changes to legislation and stricter guidance may mean many organisations will have different tools for different hazards to ensure that they comply with WHS legislation.

Control measures

A control measure is something I put between me and the hazard to prevent or minimize the risk

The benefits of assessing and managing risks

The effective systematic management of risks improves worker health and safety, as well as productivity.

Eliminating and controlling risks in the workplace helps to:

- prevent and reduce the number and severity of workplace injuries, illnesses and associated costs
- promote and improve worker health, wellbeing and capacity to work, and
- helps to foster innovation and improve quality and productivity of work.

The model Code of Practice: [How to manage work health and safety risks](#) provides practical guidance for a PCBU about how to manage WHS risks.

Duty to manage WHS risks

The model WHS laws require duty holders to manage WHS risks in the workplace.

Duty holders include:

- PCBUs
- designers, manufacturers, importers, suppliers and installers of plant, substances or structures, and
- officers.
- Workers and other persons at the workplace also have duties under the model WHS laws, such as the duty to take reasonable care for their own health and safety at the workplace.

A person can have more than one duty and more than one person can have the same duty at the same time.

Specific advice for duty holders can be found in [Chapter 1.1 who has duties for managing WHS risks](#).

A step-by-step approach to managing WHS risks

Risk management is a proactive process that helps you respond to change and facilitate continuous improvement in your business.

It should be planned, systematic and cover all reasonably foreseeable hazards and associated risks.

The four steps for managing WHS risks are:

Step 1 - Identify hazards

Find out what could cause harm.

Detailed information is in [Chapter 2 how to identify hazards](#).

Step 2 - Assess risks

If necessary – understand the nature of the harm that could be caused by the hazard, how serious the harm could be and the likelihood of it happening.

This step may not be necessary if you are dealing with a known risk, with known controls.

Detailed information is in [Chapter 3 how to assess risks](#).

Step 3 - Control risks

Implement the most effective control measure that is reasonably practicable in the circumstances and ensure that it remains effective over time.

Specific information about the hierarchy of control measures and developing and implementing control measures is in [Chapter 4 how to control risks](#).

Step 4 - Review control measures

Review the control measures to ensure they are working as planned.

Learn more about reviewing control measures in [Chapter 5 how to review controls](#).



Figure 1. The risk management process

Consulting workers

Consultation with workers and their health and safety representatives is required at each step of the risk management process. By drawing on the experience, knowledge and ideas of your workers, you are more likely to identify all hazards and choose effective control measures.

Video - [H&S - Workplace-hazards](#)

Video - [H&S - Working on a safer workplace](#)

Reasonably practicable

Deciding what is reasonably practicable to protect people from harm requires taking into account and considering all the relevant matters, including:

- the likelihood of the hazard or risk occurring
- the degree of harm that might result from the hazard or risk
- knowledge about the hazard or risk, and ways of minimizing or eliminating the risk
- the availability and suitability of ways to eliminate or minimise the risk, and
- after assessing the extent of the risk and the available ways of eliminating or minimizing the risk, the cost associated with available ways of eliminating or minimizing the risk, including whether the cost is grossly disproportionate to the risk.

Further information is available in the Guide: [How to determine what is reasonably practicable to meet a health and safety duty](#) and the model Code of Practice: [Work health and safety consultation, cooperation and coordination](#).

Video - [H&S - Work safe for moments that matter](#)

Practical examples and scenarios of the risk management process are in [Appendix B – examples of the risk management process](#).

Controlling risks using the hierarchy of control measures

The ways of controlling risks are ranked from the highest level of protection and reliability to the lowest. This ranking is known as the hierarchy of control measures.

The hierarchy of control measures can be applied in relation to any risk.

You must always aim to **eliminate the risk**, which is the most effective control. If this is not reasonably practicable, you must minimise the risk by working through the other alternatives in the hierarchy.

Administrative controls and **PPE** are the least effective at minimising risk because they do not control the hazard at the source and rely on human behaviour and supervision.

Detailed information about each control is in [Section 4.1 the hierarchy of control measures](#).

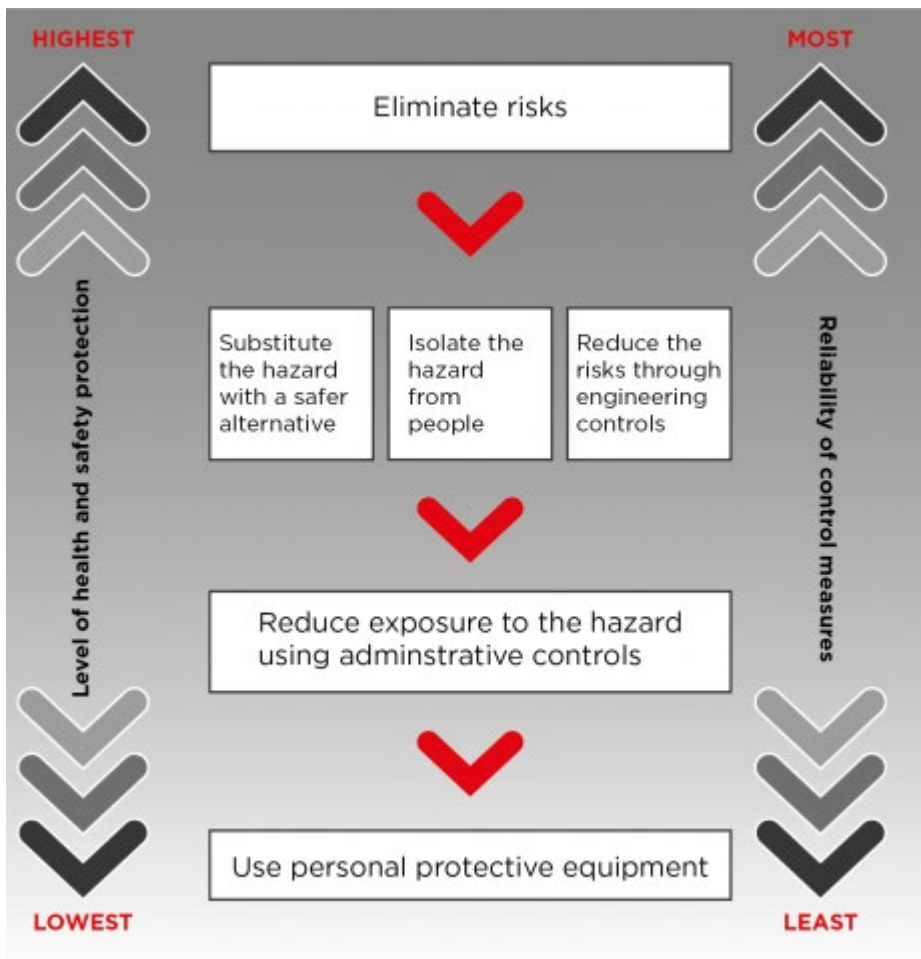

Figure 2. The hierarchy of control measures

Managing psychological risks

The risk management process that is used for physical risks should also be applied to psychological risks in the workplace.

Further guidance specific to psychological risks is available in the Guide: Work-related psychological health and safety: A systematic approach to meeting your duties, and the [Guide for preventing and responding to workplace bullying](#).

Ongoing risk management approach

Managing WHS risks is an ongoing process that needs attention over time, but particularly when any changes affect work activities.

You should work through the risk management process steps when:

- starting a new business
- expanding or purchasing an existing business
- designing and planning products, processes or places used for work
- changing work practices, procedures or the work environment
- changing organisational structure or job roles

- introducing new workers or returning workers to the workplace
- purchasing new or used equipment or using new substances
- working with a new supplier or new commissioner of your services
- planning to improve productivity or reduce costs
- new information about workplace risks becomes available
- responding to workplace incidents (even if they have caused no injury)
- responding to concerns raised by workers, health and safety representatives or others at the workplace, or
- required by the WHS regulations for specific hazards.

Details can be found in [Chapter 1.3 when should a risk management approach be used](#).

Model Code of Practice

The model Code of Practice: [How to manage work health and safety risks](#) provides practical guidance for a PCBU about how to manage WHS risks. Other approved [codes of practice](#) should be referenced for guidance on managing the risk of specific hazards.

Further advice

SWA is not a regulator and cannot advise you about identifying, assessing and controlling hazards in the workplace. If you need help, please contact your state or territory work health and safety authority.

Tools and equipment

Selecting risk assessment techniques, tools and processes

Cash flow, resources and short-term interventions may also need to be considered when you and other levels of management may need to consider when making a final decision in the resolution of risk.

What is reasonably practicable?

Section 18 of the WHS Act defines reasonably practicable as a duty to ensure health and safety that in the performance of their work, which they assess:

- The chance of a hazard and risk happening
- The amount and level of harm that could arise from that risk.
- The amount of information a person may require in regard to the risk; and
- Whether there are suitable ways in which to minimize the risk based on the resources available and suitable in the control and minimization of the risk.

Administrative controls and PPE should only be used to protect workers from risk. They should only be used when:

- The control measures that could be used are not practical for the given situation
- It can be used as an interim measure until a more appropriate control measure can be used; and
- To back up another higher control measure.

WHS Regulations provide strict instructions about the PPE that should be used at a workplace including:

- Ensuring that PPE is chosen to minimize risk to the health and safety of personnel in the workplace
- That the PPE is appropriate to the nature of the work and hazards associated with the work;
- That the PPE fits the person wearing it;

- That the worker wears the PPE as far as is practicable; and
- That sufficient PPE is available in the case that PPE should be replaced, repaired or maintained so that risk is minimized

PPE must be worn by workers as far as reasonably practicable in accordance with the instructions training and information they receive. This includes training during the coaching and mentoring process, during formal or informal training or when they are provided with procedures that require the use of PPE.

Document method and outcomes of risk assessment

Care should be taken to ensure that you separate the main information that will influence the outcomes of the risk assessment. For example: decisions may be made based on cost. In a period of recession, there may not be as much cash flow throughout the organisation as consumers decrease spending on luxury items. The fewer consumers that you have, the less cash flow you will have. This means that you will need to consider a short-term intervention until more funds are available to implement a high level on the hierarchy of risk control.

Before a final decision is made on the control measure implemented, make sure that you clearly state why you did not implement a specific control measure. This may mean that you should consider the organisations policies and procedures as they may influence your final decision. If you are not sure about the final control measure the final influence will be the control measure that is highest in the hierarchy of risk control

The steps within Learner Guide provide you with the steps involved in the completion of a risk assessment. Risk assessments will vary from organisation to organisation; however the basic steps remain the same and should include:

- Establish goals
- Identify risks
- Analyse risks
- Evaluate risks
- Determine the treatment for risks
- Monitoring and reporting on the effectiveness of risk treatments.

At this stage you are analysing the risks. As you complete each step of your research and analysis, information should be filed as per organisational procedures.

Documents are maintained as a historical record of the decisions that are made and why specific options were not chosen. This information can be used as part of the continuous improvement process. Change is a constant in business today. A risk control measure that is rejected today may become a resolution in the future. For example, a production process may be a hazard. The resolution for the process may be to become automated. If there is no automation to control the risk, then another control measure should be put in place to minimise or eliminate the risk.

If a new robot is developed in research and development or becomes available, then as part of the review process; the new robot should be reconsidered as part of the continuous improvement process. This may mean that you should review the documents to determine whether the robot should be considered as part of the required control measures.

Documented records are also kept providing evidence that the organisation has met their legal obligation of ensuring that the work environment is safe, and that the organisation is consistently improving its processes.

Records that may be kept until the analysis phase of the risk assessment may include:

- A list of resources reviewed for the hazard
- Potential risks and control measures used to minimize, eliminate or control the risk
- How information was communicated which may include copies of the communications.
- The personnel consulted and feedback received
- An outline of the procedures followed
- Control measures and how they were prioritized.
- How the risk assessment was evaluated and the processes that will influence the decision.

The method in which these records are kept will vary to the policy and procedures of the organisations. Records may be kept:

- Paper based: Filed in the appropriate file
- Electronic based: filed on the intranet
- Both paper and electronic based.

Select and use Tools small plant and equipment for tasks

Small plant and equipment are identified and checked for serviceability

All Equipment shall be regularly maintained in accordance with the Act and manufacturer's recommendations and shall be recorded in a logbook. That logbook should be sighted to verify compliance.

Video - [Tools - Electrical Safety](#)

Video – [Tools - Petrol-equipment-prestart](#)

Video – [Tools - Air-and-hydraulic-power-tool-check](#)

Video - [Tools - Hand-held-power-tool-check](#)

Hired Plant & equipment

- ensure tools & machines have been maintained by viewing the maintenance log
- complete prestart checks as usual

Methods of operation of small plant and equipment are identified

The purpose and intended use for each tool shall be identified and workers trained in their use being mindful of manufacturer's instructions and WH&S requirements Refer to SOP for Plant & equipment

Small plant

- Air compressors
- Elevated work platforms (EWP)
- Forklifts
- Generators
- Jackhammers
- Material and personnel hoists
- Mini- loaders
- Pumps

Rubber-tyred Equipment

- Brooms
- Safety equipment, including:
- Barricades

- Fall prevention
- PPE
- Scaffolds
- Signs
- Pallet trolleys
- Wheelbarrows.

WHS Requirements for the selected small plant and equipment are identified

All tools, plant and equipment shall be inspected to ensure they are fit for purpose, that manufacturer's operator's manuals are available, and operators have been trained and assessed as competent to operate the equipment.

An SOP and Risk assessment shall be available for their use.

An inspection of equipment shall be carried out on high risk plane

Confirmation is obtained that existing services have been disconnected.

For your inspections and monitoring activities to be effective you will need a thorough knowledge of worksite procedures. These will include knowledge of services. It is wise to conduct an inspection with a person who has knowledge of the worksite and is aware of the location of services or has access to Building and service plans

All of these requirements are in place to ensure your worksite complies with the designated regulations and legislation.

Once identified all services shall be disconnected by an appropriately qualified person using Lock-out and tag-out procedures. Where a service must remain live all workers shall be advised and evidenced in the SWMS. Refer to Permit processes.

Work site inspection is conducted, and hazards associated are assessed

For your inspections and monitoring activities to be effective you will need a thorough knowledge of worksite procedures. These will include all relevant workplace operating procedures, work instructions and temporary instructions.

All of these requirements are in place to ensure your worksite complies with the designated regulations and legislation.

It is important to make sure that the codes and standards you refer to are the most current versions as approved by state and federal government.

Form sample – [Site Hazard Inspection](#)

Form sample – [Office Hazard Inspection](#)

Form sample – [Workshop Hazard inspection](#)

Video - [Supervisor - The Safety Inspection Process](#)

Video - [Supervisors - Hazard inspection workshop](#)

Video - [Supervisors - Hazard inspection residential](#)

[Supervisors - Hazard inspection residential 2](#)

Video - [Supervisors - Hazard inspection roadside](#)

Video - [Supervisors - Hazard inspection scaffold](#)

Purpose of Inspection

A work site inspection is required to identify the hazards associated with individual demolition hot work tasks and to identify how those tasks can be managed.

Safe work method is amended

Monitor Conditions of Work

As the supervisor, it is your responsibility to conduct regular monitoring of tasks and activities to ensure that any changes in conditions are identified and responded to quickly.

For your inspections and monitoring activities to be effective you will need a thorough knowledge of worksite procedures. These will include all relevant workplace operating procedures, work instructions and temporary instructions.

Form sample - [SWMS](#)

All of these requirements are in place to ensure your worksite complies with the designated regulations and legislation.

It is important to make sure that the codes and standards you refer to are the most current versions as approved by state and federal government.

All changes must be responded to in accordance with the procedures for your site and the permit conditions.

You must ensure the work permit remains current and valid. Changes to work conditions (such as the identification of new hazards) or a failure to follow permit conditions may mean that the permit becomes invalid and will have to be revoked before the work has been completed.

You should check that:

- Problems are being anticipated and efficiently resolved.
- Changing conditions and circumstances are being responded to appropriately and effectively.
- The performance of monitoring and testing equipment is checked against a standard sample. If work stops for a certain period of time (e.g. over an hour) the workspace will need to be tested again.

In inspecting the work area you may also be supervising workers and monitoring their activities for compliance with site procedures.

Changes in Work Environment

During the day there are many events that may alter the safe outcomes of the day including:

- Weather conditions change.
- Timeframes have expired.
- Permit conditions change.
- There is a change of workers.
- Non-compliance has occurred.
- Equipment is recalibrated.
- Adverse test results are recorded.

The outcomes of any inspections shall be conveyed to workers by discussion or toolbox talks as appropriate according to the requirements of this workplace and or your WH&S Management Plan.

Work area is prepared

The work area shall be prepared in accordance with the SWMS and SOP that have been previously prepared according to site safety and workplace requirements.

An inspection shall be carried out prior to works to ensure that the area has been adequately prepared and all hazards are identified

Small plant and equipment are selected.

All plant & equipment shall be regularly maintained in accordance with the manufacturer's recommendations

Video - [Plant - Toolbox - Plant](#)

Competent Operators

All workers shall receive adequate training to ensure sufficient competency prior to unsupervised use of tools. No worker shall work with tools alone unless assessed as competent to work alone

Form sample – [Operator VOC](#)

Maintenance

All tools shall be regularly serviced and maintained in accordance with manufacturers' recommendations. Maintenance schedules should be established (to manufacturers specifications) that determine frequency of servicing and provide a checklist of items requiring inspection, testing or repair, lubrication or adjustment.

Pre-Operational Checks are completed

Prior to use of any plant a daily safety check including guarding, wiring, switches, smooth movement of moving parts, jamming of equipment or materials, waste chutes and supplied PPE.

Form sample – [Pre-start checklist](#)

Video - [Plant - pre-start](#)

Small plant and equipment are used for their intended purpose

Site inspections will ensure that all activities are being completed to the required standards and in line with the specified procedures for the performance of tasks and the use of tools and equipment. It is essential that all tools and equipment are used in accordance with Manufacturer's recommendations including those recommendations for service and maintenance.

Video - [Plant – operation](#)

Any variation in conditions, situations, workers, processes, tools or equipment could impact on the validity of the work permit.

Small plant and equipment are cleaned, checked, maintained

Ensure that all plant and equipment is maintained, cleaned and stored according to the manufacturer's guidelines and site requirements.

Also check that procedures are followed to isolate and tag out any damaged or defective items.

Permits to Work

The work permit system covers the issue of any and all work permits and is used by organisations to control worksite situations and tasks involving identified hazards.

Permit Control Systems

Each site will have a permit control system that is based on the tasks and activities being carried out. You need to understand all aspects of the system that applies to your site. This could include:

- Types of permits.
- Frameworks relating to legislation, regulations and/or standards.
- Roles and responsibilities of concerned parties under the permit system.
- Equipment which can and cannot be used for different types of permit.
- Alternative ways of conducting a job.

To effectively work under your site permit system you must have a solid understanding of the relevant legislative and regulatory requirements under which permit systems operate. This will help you to identify when permits are required.

As someone who issues permits, you also need to understand your organisation's standard procedures and work instructions, and be able to implement them correctly, safely and within appropriate timeframes.

A working knowledge of the procedures used during all hazardous tasks and activities will ensure that you place the correct conditions and requirements on the permit.

Permit Requirements

Requirements identified on the permit may include:

- Testing of atmospheric conditions.
- Ventilation.
- Control measures such as isolation, barriers, tag out/lockout signs.
- Communications.
- Incident response.

In issuing permits it is important to make sure that the work will be carried out by a competent person. A 'competent person' is someone who has, through a combination of training, education or experience, acquired knowledge and skills so they can correctly perform a specified task.

Monitor Variables

During the permit issuing process you will also need to monitor key variables such as:

- Types of permit issued.
- Permit issuing procedures to be used if there are different procedures for different permit types.
- Protocols for extending the work activities beyond the end of shift.
- Permit handover procedures.

Other appropriate protocols and processes as deemed correct by site conditions.

The first step in issuing work permits is to identify and confirm with appropriate workers the need for a permit

Confirm the Need for a Work Permit

Before you can issue a permit, you must identify the type of work being done and confirm with the appropriate workers that a permit is in fact needed.

Consider: Can the work be performed by another means without workers being at risk?

Can we remove the machine from the confined space under a permit for a shorter work duration, repair the machine and return it to the confined space later thus reducing the time at risk

Types of Work Permit

The types of permits and the work they cover include:

- General permit to work.
- Electrical – for activities involving work with electricity or electrical appliances.
- Services isolation
- Working alone
- Excavation
- Confined space
- Hazardous Chemicals
- Hot work
- Working at heights.

Form sample – [Permit to work](#)

Identify the Correct Permit

When deciding on the type of permit/s required you will need to consider the materials, equipment, processes and organisational procedures involved in the activity or situation.

You can then be sure that the correct permit is issued with the most appropriate conditions and requirements for the work being completed.

You will also be able to monitor the work to check it is being completed in accordance with the permit.

Always refer to your site procedures and safety officers if you need assistance in identifying the correct permit for each situation.

Hot work is work that WILL generate any source of ignition, such as flame, spark or temperature sufficient to ignite flammable material.

Check Permit Documentation

As the permit issuer, you need to make sure that all conditions are documented on Operational Procedures, Processes and Production Sequences.

Operational procedures and processes, and production sequences you need to check may include:

- Sites under which permit activities must be applied.
- Type of permit to be executed.
- The focus of the operations of work systems and equipment, i.e. objectives, procedures and equipment to complete the whole job effectively and safely.
- Production workflow sequences, including processes and timelines to ensure all work meets safety and quality standards.
- Types of tools and equipment to be used (e.g. atmospheric testing and monitoring devices) – includes links or lists of the procedures and processes for selecting and operating each tool or piece of equipment.

- Start time and duration of work to be done. The permit in accordance with regulatory and organizational requirements.

Permit Details

Communication requirements and personnel/worker details to be checked may include:

- Size of work team.
- Persons in the work area/rotation of people in the location.
- Standby workers and emergency/incident response procedures.
- Communication procedures, protocols and equipment.
- Authorisation from a competent person.

All of this information needs to be adequately gathered and documented to ensure that all work is conducted in a safe and efficient manner.

It also helps to identify situations of non-compliance and provides guidance on how to act in changing situations.

Validity Period

When issuing a work permit, you need to determine an appropriate validity period. This is the length of time for which the permit will be current.

When determining the validity period you need to consider the tasks and activities to be undertaken.

This includes looking at:

- The complexity of the work – more difficult or involved tasks might need a longer validity period.
- Normal or standard times taken to complete the tasks – check the permit register or other permits for timeframes for similar work.
- Any component tasks involved in the job that may lead to more time being needed.

The validation period should also give you enough time to check that all permit conditions have been met.

Validate the Permit

Before the permit can be authorised it must be validated.

Validating the permit means checking that all conditions have been met. These conditions will vary depending upon the nature and scope of the permit but could include:

- Hazard controls.
- Atmospheric testing requirements.
- Environmental requirements.
- Any other listed requirement or condition.

You should also resolve any problems with the validation of a permit such as:

- Provision of the wrong permit.
- Need for additional permits.
- Incorrect information being supplied with the permit.
- Errors being made in the understanding of permit data.

Once you are satisfied all conditions and requirements have been met, the permit can be signed off as valid.

Authorising the Permit

With the work permit now completed you can authorise and issue it.

Follow your site procedures for permit authorisation. This could include listing the permit in the issue register.

In completing and issuing work permits it is important that you have adequate writing skills to complete workplace forms and produce reports. This means being able to write neatly and legibly. You also need to make sure that what you are writing down is clear and easy to follow. If you have any difficulties filling out forms or completing reports, speak to your supervisor or manager who may be able to arrange some assistance or training for you.

Consultation with Permit Workers

While the permit is now authorised, you still need to discuss all conditions and requirements with the permit recipient and make sure they understand and agree to abide by them. Be prepared to explain any details if necessary, so that you are satisfied the recipient is well aware of what needs to be done to meet the terms of the permit. The recipient should also understand the consequences of non-compliance.

After you are satisfied that the recipient is fully aware of and in agreement with the permit requirements, you will need to get them to sign for the permit.

The permit must be signed in accordance with site procedures. Signing for the permit means the recipient is now responsible for ensuring that conditions and requirements are initiated.

Be aware however that you, as the permit issuer, will still need to keep monitoring the situation and conditions.

Carry Out Regular Inspections

Part of your role as a permit issuer is to carry out inspections of the work area, or to ensure that they are carried out by another designated person.

It is important that regular inspections of the progress of work are undertaken to make sure that it complies with the permit conditions and that any changes in work conditions do not affect the validity of the permit.

Form sample – [Site Hazard Inspection](#)

Form sample – [Office Hazard Inspection](#)

Form sample – [Workshop Hazard inspection](#)

Display Permit

Form sample – [Permit to work](#)

Work permits must be available at all times and displayed in a prominent position. Depending on the needs of the task, the permit conditions and the organisational requirements this may be at or near the worksite.

Requirements for displaying permits will generally be clearly outlined on the work permit itself. This could mean:

- Displaying the permit in a mounting on a gate, fence, sign-in point or other designated locations.
- Having the permit stored on site in a readily accessible folder. The permit is carried in a worker's pocket or toolbox and is available for viewing immediately on request.

- If the work is being carried out in multiple locations, the permit documentation should be kept by an authorised person.
- All workers should be aware of the permit's location so that they can refer to it when necessary. The permit should be kept in a clean condition so that the information can be clearly read without causing confusion.

Always check before, during and at the completion of the tasks and activities to ensure the permit is being displayed in accordance with the requirements.

Review the Permit

The work permit will need to be reviewed if circumstances have changed.

As the permit issuer you will be required to ensure that the permit is reviewed.

You could do this yourself or you may have to arrange for it to be done by another designated staff member, depending on site procedures.

To reviewed and revalidate the permit, you will normally need to ensure the current conditions are reflected in any conditions and requirements on the new permit. If necessary, you may need to undertake a new hazard analysis.

Check Job Status and Closing the Permit

Once all tasks have been completed, the work permit can be closed.

Before this is done, however, you need to check the status of the job and that all work activities have been carried out in according to the permit conditions.

It is therefore necessary to conduct a close out inspection.

It is crucial to make sure that all conditions on the permit have been met.

Always double-check that the work undertaken satisfies all permit conditions

When you are satisfied that all permit requirements are met and the worksite has been left in a safe condition, you can sign off the required documentation and close the work permit.

Make sure you follow standard operating procedures for signing off and closing out permits.

You may need to get the permit holder to sign and date the permit, confirming that all conditions have been met.

Alternatively a supervisor may be required to sign the permit after inspecting the area and agreeing the tasks are complete.

It is then up to the manager to sign off and enter the details in a register of permits that have been closed out.

Hot Work

Plan & prepare

'Hot work' can include tasks such as:

- Oxy cutting and welding.
- Brazing and soldering.
- Arc welding.
- Repairs and alterations done using heat producing equipment such as blow lamps.
- Grinding and high-speed friction cutting.

If a worker has to undertake welding or any other allied process, they must abide by the requirements outlined in Australian Standard AS1674.1 Safety in welding and allied processes this standard covers

Hot Work Hazards Include:

- Fire
- Explosion
- Burns
- Eye Injury
- Toxic Fumes

For your safety, know the:

- work area
- material
- equipment

[Video – Hot Works - Hot Work](#)

[Video – Hot work - near explosive substances](#)

[Video – Demo – Hot Work Hidden Hazards](#)

Hot Work Permits

Used for all Hot Work outside of Authorized Hot Work Areas:

- Provides permission
- Defines job
- Remove fire hazards
- Fire watches
- Area inspection
- Defined time
- Specific precautions
- Post at job site

Form sample – [Permit to work](#)

Hot Work Restrictions

No Hot Work in areas:

- Unless authorized by management.
- where sprinkler system does not work
- with explosive atmospheres
- near storage of large quantities flammable or combustible material

Select tools

Personal Protective Equipment

- Respirator
- Welders Glasses
- Welders Helmet
- Hot work gloves
- Leather cape, sleeves, apron, and leggings

Respiratory protection and mechanical ventilation may be required for cutting or welding of certain specific metals & compounds

Complete cutting, grinding hot work

Perform the task to ensure others are safe

Video - [Hot work and welding near explosive substances](#)

Disconnection of services

For your inspections and monitoring activities to be effective you will need a thorough knowledge of worksite procedures. These will include knowledge of services. It is wise to conduct an inspection with a person who has knowledge of the worksite and is aware of the location of services or has access to Building and service plans

All of these requirements are in place to ensure your worksite complies with the designated regulations and legislation.

Once identified all services shall be disconnected by an appropriately qualified person using Lock-out and tag-out procedures. Where a service must remain live all workers shall be advised and evidenced in the SWMS

Form sample – [Permit to work](#)

Potential explosions

- Drums, barrels, tanks or other containers must be thoroughly cleaned of flammable material
- Pipelines or connections to drum or vessel must be disconnected or blanked.
- Hollow spaces, cavities or containers must be vented to permit the escape of air or gases

Clean-up

[Refer to Housekeeping](#)

Work safely at heights

Identify work area requirements.

Refer to SWMS and Scope of works

Access work area.

Fall protection equipment where required is correctly fitted, adjusted and anchored

Installation of Fall protection shall be performed by licenced personnel

Videos -
Fall Protection
Fall Protection a light hearted approach
Fall Protection Can Save Your Life
Ladder Safety 1 Introduction
Ladder Safety 2 Choosing the Right Ladder
Ladder Safety 3 Job Constructed Ladders
Ladder Safety 4 Ladder Setup
Ladder Safety 5 Safe Use
Falls from Ladders
Ladder Safety: Stepladders
Ladder Safety: Extension Ladders
Ladder Safety: Ladders on Scaffolds

A permit to work is required for work at heights.

Form sample – [Permit to work](#)

Arrangements are made to appropriately install required equipment taking account of all potential hazards

Installation of edge protection shall be performed by licenced personnel

Video - [Falls through Openings](#)

Video - [Worker Falls Down Vent Shaft](#)

Video - [Instructions to assemble mobile scaffold](#)

Video - [Scaffolding for beginners](#) by Kennards Hire

Appropriate methods are used to access work area for self, tools and equipment, and materials.

Elevating work platforms (EWP)

Elevating work platforms refers to edge-protected platforms that can be raised or lowered or positioned in a way to provide a safe work surface at heights. They must be designed, manufactured, maintained and operated with regards to the Australian Standard. When using EWPs, users must be wearing safety harness or an individual fall-arrest system.

Although EWPs are edged protected, some work undertaken on it will still require the user to lean out of the cage to some extent. In high wind gusts, EWPs can become unstable and there is also the risk of sudden loss of hydraulic pressure.

[Training information](#)

[Video - Using elevating work platforms safely](#)

[Video - Safely loading and unloading elevating work platforms](#)

Working Platforms

A ladder is not working platform, it is an access way.

[Video - Standing on the Edge](#)

A working platform used on a project shall be designed to carry safely all imposed loads and shall be constructed of scaffold planks.

A working platform used on a project shall:

- (a) If used solely by a scaffolder or rigger for the purpose of erecting or dismantling scaffolding or rigging, be not less than 225mm in width.
- (b) If used by a painter working with trestles, be not less than 225mm in width.
- (c) In any other case, be not less than 450mm in width.

Where materials or tools are to be placed on a working platform, the platform shall be planked to the full width of the scaffold.

A working platform shall be secured to prevent dislodgment and a scaffold plank shall overhang a putlog or other support by not less than 150mm nor more than 300mm, except that where a scaffold plank is lapped, the maximum overhang may exceed 300mm.

A working platform shall not be set at a greater slope than 1 vertical to 6 horizontal.

A working platform shall be erected for working on a ceiling and shall have the scaffold planks:

- (a) Spaced no more than 225mm apart where the height from the floor to the ceiling is less than 3m or
- (b) Close-laid where the height from the floor to the ceiling exceeds 3m.

The site supervisor shall ensure instructions are given to workers to ensure that materials are placed appropriately

Modular Scaffolding equipment is delivered in crates that keep components separated, protected and easy to use. The scaffold components should be returned to the crates.

Mobile scaffold is delivered unpackaged.

Ensure all components are received and stored to avoid damaged

Where scaffold is to be raised to location by crane or similar ensure the components are banded to minimise the risk of falling objects

All equipment shall be loaded and unloaded in such a way as to minimise damage to components, property and people.

Tools and materials are placed to eliminate or at least minimise the risk of items being knocked down.

Ensure tools and equipment cannot fall, are retained by toe-boards or lanyards are used

Conduct work tasks

Work is conducted following workplace approved procedures

To manage the risk of falls from working at heights, one is required to follow the hierarchy of controls for work at height as follows ([Refer to Hazard ID](#)):

- Totally avoid the risk by not working at height. If this is not practical, then
- Isolate worker from risk by using work equipment or other measures to prevent falls, or
- Where the risk cannot be eliminated, use other controls to minimize the distance and consequences of a fall should one
- Passive fall protection system

A passive fall protection system is a system used to create a safe working platform while working at heights. Some forms of passive form protection system are discussed below.

Fall protection equipment is kept in place and adjusted appropriately to cater for movement during work.

Guardrails, Midrails and Edge Protection

Video - [Scaffold Safety](#)

Toe Board – means a vertical barrier to prevent the fall of tools or materials.

On a project, guardrails, midrails and edge protection shall be provided so as to guard the edge of any area where persons or materials are likely to fall.

A guardrail, midrails and the supporting members of a guardrail or midrails shall be capable of resisting whichever of the following live loads produces the most adverse effect:

- (a) A force of 550N acting outwards or downwards at any point, or
- (b) A force of 330N per linear metre uniformly distributed load acting outwards or downwards.

A guardrail and midrails shall be erected:

- (a) To the exposed edges of stairs and ramps.
- (b) To the exposed edges of working platforms or any other place where a person can fall 2.0m or more:

NOTE: The National Standard states, (where a person can fall 2m or more)

- (c) Where a person could fall onto or into any substance likely to cause injury or be harmful to that person.

NOTE: The National Standard states, (where tools or material can fall 2m).

- A guardrail shall be positioned no less than 900mm or more than 1100mm above the edge being protected.
- A midrails shall be positioned not less than 450mm or more than 600mm above the edge being protected.
- The exposed edge being protected by a guardrail or midrails shall not extend beyond the vertical line drawn from the inner face of the guardrail by more than 200mm.
- toe board shall be erected to the exposed edges of a working platform or any other place where tools or material can fall 2.4m or more.
- A toe board shall be not less than 225mm high and extend to a height equal to or greater than the height of the tools or materials being stored.

Scaffold components and fall barriers are kept in place during work.

Scaffolding - A scaffolding system is a temporary structure that is specifically erected to support access or working platforms. It involves the interlocking of different components to provide a safe and stable working platform. They are generally made from steel or aluminium. All scaffolds must comply with the Australian Standard set in AS/NZS 157 and AS/NZS 4576:1995.

Some hazards associated with work involving the erection, use, maintenance, alteration and dismantling of scaffolds are:

- scaffolding collapse (before, during and after the erection of the scaffold)
- work near overhead electric lines
- mobile plant and other workplace traffic
- mixing components from different scaffold systems
- falls from heights
- falling objects
- manual tasks.

Some examples of scaffolding system are trestle scaffolds and step platforms.

Scaffolding

At a workplace, scaffolding shall be designed, supplied, erected, used and dismantled in accordance with the requirements of:

- (a) AS1575 Tubes, couplers and accessories used in metal scaffolding.
- (b) AS4576 Code of Practice for metal scaffolding (SAA Metal Scaffolding Code).
(Subject to the modification that in clause 4.5 (a) omit the expression 2m and substitute the expression 2.4m)

Mobile scaffold

REFER MOBILE SCAFFOLD ERECTION GUIDE PROVIDED BY THE MANUFACTURER

Modular scaffold

REFER MODULAR SCAFFOLD ERECTION GUIDE PROVIDED BY THE MANUFACTURER

Egress from work area is completed following work site supervisor approved methods for self, tools, materials and environmental requirements.

Ensure appropriate egress methods are installed considering potential emergencies

Work In Confined Spaces



Confined space

An enclosed or partially enclosed space that is at atmospheric pressure during occupancy and is not intended or designed primarily as a place of work, and—

A. Is liable at any time to—

- Have an atmosphere which contains potentially harmful levels of contaminant;
- Have an oxygen deficiency or excess; or
- Cause engulfment; and

B. Could have restricted means for entry and exit.

Video – [Confined Space - identify](#)

AUSTRALIAN STANDARD - AS 2865 - 2001

Standards Australia / WorkSafe Australia - Safe Working in a Confined Space

Definitions

Atmospheric monitoring

The continuous measurement of oxygen levels or selected atmospheric contaminants over an uninterrupted duration of time.

Atmospheric testing

The short-term testing, which is not continuous, of oxygen level and atmospheric contaminants.

Competent person

A person who has, through a combination of training, education and experience, acquired knowledge and skills enabling that person to perform correctly a specified task.

Video - [Confined space - Test to live](#)

Contaminant

Any dust, fume, mist, vapour, biological matter, gas or other substance in liquid or solid form, the presence of which may be harmful to health and safety.

Entry (to a confined space)

When a person's head, i.e. the breathing zone, or upper body is within the boundary of the confined space.

Explosive limit

Lower explosive limit (LEL)

In relation to a flammable contaminant, the concentration of the contaminant in air below which the propagation of a flame does not occur on contact with an ignition source.

Upper explosive limit (UEL)

In relation to a flammable contaminant, the concentration of the contaminant in air above which the propagation of a flame does not occur on contact with an ignition source.

Exposure standard

An airborne concentration of a particular substance in the person's breathing zone, exposure to which, according to current knowledge, should not cause adverse health effects nor cause undue discomfort to nearly all persons. The exposure standard can be of three forms: time-weighted average (TWA), short-term exposure limit (STEL) or peak exposure limit.

The following terms are used in calculating levels of atmospheric contaminants:

- a. Time-weighted average (TWA) The average airborne concentration of a particular substance when calculated over a normal eight-hour workday, for a five-day working week.
- b. Short-term exposure limit (STEL) A 15-minute TWA exposure which should not be exceeded at any time during a workday even if the eight-hour TWA average is within the TWA exposure standard. Exposure at the STEL should not be longer than 15 minutes and should not be repeated more than four times a day. There should be at least 60 minutes between successive exposures at the STEL.
- c. Peak A maximum or peak airborne concentration of a particular substance determined over the shortest analytically practicable period of time, which does not exceed 15 minutes.

Flammable range

The range of flammable contaminant (percentage by volume) in air in which an explosion can occur upon ignition. Expressed by lower explosive limit (LEL) and upper explosive limit (UEL).

Hot work

Welding, thermal or oxygen cutting, heating, including fire-producing or spark-producing operations that may increase the risk of fire or explosion.

Safe oxygen range

A minimum oxygen content in the atmosphere of 19.5 percent by volume under normal atmospheric pressure (equivalent to a partial pressure of oxygen (pO₂) of 19.8 kPa (148 mm Hg), and a maximum oxygen content in the atmosphere of 23.5 percent by volume under normal atmospheric pressure (equivalent to a partial pressure of oxygen (pO₂) of 23.8 kPa (179 mm Hg).

At pressure significantly higher or lower than the normal atmospheric pressure, expert guidance should be sought.

Shall

Indicates that a statement is mandatory.

Should

Indicates a recommendation.

Stand-by person (emergency response initiator)

A competent person assigned to remain on the outside of, and in close proximity to, the confined space and capable of being in continuous communication with and, if practical, to observe those

inside. In addition, where necessary, initiate emergency response procedures and operate and monitor equipment used to ensure safety during entry and work in the confined space.

Written authority

A document which permits entry to or work in a confined space.

Form sample – [Permit to work](#)

Video – [Confined space - Toolbox - Procedures](#)

Design, Manufacture, Supply And Modification

- The confined space shall be designed, manufactured and supplied so as to minimize the need to enter the confined space.
- The confined space shall be designed, manufactured and supplied so as to minimize the risks associated with work in a confined space.
- Openings for entry to and exit from a confined space shall be of adequate size to permit rescue of all persons who may enter the confined space.
- Any modification to a confined space shall not detrimentally affect the safe means of entry to, exit from, or work in the confined space.

Plan and prepare for working in confined space

Access, interpret and apply procedures for confined space entry and the environmental management plan and ensure the work activity is compliant
[\(Refer to Hazard ID\)](#)

Video - [Confined space 1 safe yesterday , deadly today](#)

Prior to any person entering a confined space, all potentially hazardous services, including all process services, normally connected to that space shall, where it is possible to do so, be isolated in order to prevent—

- The introduction of any materials, contaminants, agents or conditions harmful to persons occupying the confined space; and
- The activation or energizing in any way of equipment or services which could pose a risk to the health or safety of persons within the confined space.

Where necessary, the confined space shall be cleared of contaminants by use of a suitable purging agent. The purging agent or any gas used for ventilation purposes shall never be pure oxygen or gas mixtures with an oxygen content greater than 21%.

Atmospheric testing and monitoring shall be carried out consistent with the hazards identified and the risk assessment

Obtain, confirm, clarify and apply work instructions and agreed procedure

Identify the scope of works to be completed

Obtain, confirm, clarify and apply safety requirements

All persons with work activities related to a confined space shall be trained and assessed as competent to perform those activities.

Training shall include at least the following:

- The hazards of confined spaces.

- Assessment procedures.
- Control measures.
- Emergency procedures.
- The selection use and maintenance of safety equipment.
- Legislative requirements.

Persons shall be trained and assessed as competent to carry out their activities where they—

- perform work in or on confined spaces;
- perform confined space assessments;
- issue written authorities;
- design and lay out the workplace;
- manage and/or are responsible for the direct control of the work in confined spaces;
- maintain equipment used for ensuring the safety of persons in the confined space;
- provide, fit, wear and maintain personal protective equipment;
- are on stand-by; and
- are involved in emergency response and first aid procedures.

The training which is provided to persons shall be recorded.

Video – [Confined Space - awareness](#)

No persons shall enter a confined space unless—

- a review of the risk assessment has been completed in accordance with Clause 9.1 and 9.2;
- a written authority is provided to, or completed by, the person responsible for direct control of the work in the confined space;
- the written authority includes any control measures or precautions necessary for the safe entry and execution of the work;
- they are advised of, understand and comply with the requirements of the written authority; and
- a record of their presence in the confined space is maintained.

Where the risk assessment indicates a risk to health and safety, the control measures shall require a stand-by person or persons to be outside the confined space while it is occupied.

Prior to any person entering a confined space, and during any occupancy of the confined space, appropriate signs and protective barriers shall be erected to prevent entry of persons not involved

Suitable equipment shall be provided including, where necessary, equipment for —personal protection;

- emergencies including rescue;
- first aid; and
- fire suppression.

The equipment shall be appropriate to the work to be carried out in the confined space and maintained in a proper working condition. The personal protective equipment and emergency response equipment shall be selected and fitted to suit the individual.

Obtain and confirm authorisation (entry permit) meets regulatory requirements

(Refer to [Permits to Work](#))

Complete the Confined space **Form sample** – [Permit to work](#)

Video – [Confined space - Toolbox - Safety Check](#)

Confirm the emergency response procedure is with the stand-by person and understood

Discuss the emergency procedure with the assigned stand-by person

Video - [Confined space 3 Rescue](#)

Stand-by Persons

A stand-by person must have received training in confined space entry

A stand-by person should be provided where:

- There may be other risks to the health and safety of persons entering the confined space;
- There may be a risk of fire or explosion;
- The work to be performed may generate risk to health and safety;
- Atmospheric contaminants are present or may be present in concentrations above the exposure standards;
- Equipment or conditions outside the confined space require control or monitoring to ensure the health and safety of persons in the confined space (for example, ventilation, respirator air supply, vehicles and weather); or
- There may be a risk of entrapment or engulfment

Video - [Confined space - Rescue](#)

Identify, obtain and implement signage and barrier requirements

The following signage shall be displayed at all entries to confined space.

- Danger Confined Space.

Ensure adequate barriers are in place to prohibit access by those not authorised to enter

Select tools and equipment for the tasks, check for serviceability and rectify or report any faults

Select the tools outlined in the entry permit

Respirators

Suitable supplied air or respiratory protective devices complying with AS / NZS 1716 should be worn where:-

- The results of the assessment or monitoring indicate that a safe atmosphere cannot be established or may not be maintained; or,
- The nature of the work procedure within the confined space is likely to degrade or contaminate the atmosphere in the confined space (for example, painting or removal of sludge)

Respiratory protective devices should be selected, fitted, used, stored, maintained and inspected in accordance with AS / NZS 1715

A person may not use breathing apparatus unless they have been provided training and certified in the use of breathing apparatus. N.B. A diving certificate is not recognised as certification to use breathing apparatus

Safety Equipment

Suitable safety equipment shall be provided, used and appropriately maintained and shall include but not be limited to:

- Personal protection
- Rescue
- First aid
- Fire suppression

Safety Harnesses and Lines

Suitable safety harnesses and lines, complying with AS 1891 should be worn where:

- There is a hazard of falling;
- Rescue of direct route, either vertical or horizontal is practicable;
- The selection of the type of safety harness or safety line should be in accordance with AS 2626

Identify, confirm and apply the environmental protection requirements

Refer to section on Environmental controls and entry permit

Position rescue equipment by the entry permit

Appropriate rescue first aid procedures and provisions shall be planned, established and rehearsed. Have available contact details for Fire and Rescue.

The following rescue equipment shall be available for use. All rescue equipment shall be checked six (6) monthly to ensure its compliance

- Ladder
- Rope and harness
- Tripod
- Man-cage and forklift
- Elevating work platform
- Crane and doggers box
- Stretcher
- Breathing apparatus
- Torch
- Communication equipment

In cases of emergency response, those persons involved in the response shall be made aware of the conditions in the confined space prior to any entry.

Performing work in confined space

Gain access to confined space

Ensure a safe method of access and egress is provided.

Correctly apply tagging and lock-out procedures

Isolate all services and tag-out to prevent re-activation

Video - [Lockout: A Guide to Safe Work Practices](#)

Video - [Electrical Safety: Underground Contact](#)

Enter the confined space correctly

Enter as instructed in the permit

Maintain ongoing communication with the stand-by person

Ongoing communication via electrically intrinsically safe two-way radio unless the Confined space does not contain a flammable atmosphere

Comply with entry permit requirements

At all time workers will comply with the permit

Monitor and adhere to allocated entry time

The stand-by person shall monitor the time and advise workers when it is time to leave the confined space

Exit confined space

Exit confined space correctly

Exit the confined space by reversing the entry process

Recover tools, equipment and materials

All tools and equipment shall be recovered, checked for serviceability and stored

Conduct inspection of the confined space

Inspect the confined space to ensure no equipment or personnel are left behind and work is complete.

Secure access to the confined space

Close and secure the access hatch

Remove tagging and lock-out

Return isolated equipment to a serviceable state by returning energy source and removing tags

Accurately complete confined space entry permit

Close-out the permit. The following documentation shall be kept and maintained for the time specified unless longer periods are necessary, as in the case of health surveillance being required:

- Written authorities, for one month.
- The current recorded risk assessment reports for work in a confined space, for five years from the time of their validity.
- Training records, for the term of the Worker's employment.

Clean up

[Refer to housekeeping](#)

General Plant operations

Plan and prepare

Refer to [Hazard Identification](#) for information on Safe operation

Video - [Plant - Toolbox - Plant](#)

Competent Operators

All workers shall receive adequate training to ensure sufficient competency prior to unsupervised use of plant. No worker shall work with plant if he/she is alone in the factory.

Form sample [Operator VOC](#)

Registrable Plant

Shall be registered with the Regulator as required by Legislation.

High Risk Work

Operators of certain plant require certificates of competency e.g. forklift, elevated work platforms. No person shall work in a prescribed occupation unless they are accredited to do so or are being trained to do the work and are under supervision of a competent person who ensures all training is recorded.

Design Standards

Ensure all plant has been designed and constructed to an acceptable standard (AS/NZ Standards or similar).

Control Devices

If any moving part may endanger any person when plant starts up it must be fitted with an audible and or visible alarm e.g. forklift or elevating work platform.

Noise Levels

Ensure noise levels from the machines do not subject workers to higher than a daily noise dose of 1 (refer AS 1269 Acoustics Hearing Conservation). If necessary, provide sound dampening devices or enclosures.

Video - [The Hearing Video](#)

Terminology

The operator of the machine must know and understand the terminology below:

BCM	Bank Cubic Meters – volume of ore/waste material to be mined.
TBM	Temporary Benchmark – flagged off area used daily by surveyors and distinguished by marker pegs and tape.
RL	Reduced Level - term used by surveyors to measure the working level in a pit.
High wall batter	Angle of the high wall - set by client and important to safety of pit.
Toe	Area of material that's been blasted which cannot be excavated by normal means (lump on the pit floor).
Bund or Bund wall	A stockpile of material that has been made to prevent access and noise pollution. Can be used as a safety bank that separates one area from another.
Go-Line	Park up area for all working machinery
V-Drain	A V ditch in the ground. Trucks dump dirt on top of it – dozer pushes material off. Can also be used as a safety feature at the Go-Line to stop equipment from rolling. Used in areas where the ground is unreliable.

Tramming	Term used for when track machinery (e.g. shovel, excavator, or dozer) is moving from one area to another.
Slip	An area on the high wall that comes loose and slides down the wall
Face	Section of blasted dirt being dug out.
Sump	Hole in the ground (water catchment) – generator pumps water from

What is fatigue?

Fatigue is sleepiness, a loss of alertness and decreased concentration. Fatigue can lead to:

- Poor judgment;
- Slower reaction;
- Decreased driving skills level;
- Increased risk of accidents.

There are two types of fatigue, acute and chronic.

Acute fatigue

Acute fatigue is a result of too little sleep or poor-quality sleep and it causes:

- Reduced coordination;
- Reduced alertness;
- Reduced concentration;
- Decreased attention span;
- Increased likelihood of falling asleep on the job.

Chronic fatigue

Chronic fatigue occurs when there is not enough time for full recovery between episodes of acute fatigue and may cause:

- Continual decline in performance;
- Impaired judgment;
- The taking of unwarranted risks.

Effects of fatigue

Video - [Sun Safety at Work:](#)

Video - [Plant – safely home](#)

The effects of fatigue are as follows;

- Tiredness;
- Loss of alertness;
- Falling asleep – possibly at the wheel/controls;
- Poor memory;
- Bad mood;
- Poor judgment;
- Slow reactions.

Causes of fatigue

The causes of fatigue are as follow:

- Body clock factors;
- Sleep factors;
- Work factors;
- Health factors.

Reducing fatigue

Please find following ways in which fatigue may be reduced:

- Listen to your body clock – when you feel tired, sleep;
- Stick to regular sleep/waking routines;

- Pay off sleep debt;
- Recognise symptoms of fatigue and act on them;
- Develop techniques for arraying alert.

Potential Hazards And Control Measures

Hazard	Control method
Underground/Overhead Utilities e.g. gas, telecom, electrical:	Locate, mark and expose any underground services by hand prior to the machine excavating. Visually inspect the site, especially for overhead wires. Check all other authorities' site plans.
Waterlogged Ground:	Install de-watering system. Use closed sheeting or 'shorco' type shoring to prevent collapse.
Pockets of Unstable Ground:	Shore trenches using closed sheeting or trench shields where the unstable ground is located.
Other Trenches Close By:	Check plan and leave an adequate distance between the existing trench and the new trench. Shore the new trench using the appropriate method e.g. closed, open, shields or struts etc.
Uneven/Sloping Ground:	Level a track for the excavating equipment. Place the soil from the trench on the downhill side of the excavation.
Watercourses/Creeks etc.:	Install extra shoring where necessary, check for seepage, check all shoring and monitor regularly.
Building and Structures:	Install extra strength shoring to avoid property damage. Under some circumstances it may be necessary to leave the shoring in place and backfill the lot.
Traffic:	Barricade and protect the work area. Install extra shoring if required. Keep the traffic well clear of the trench line and be aware of the problems with traffic vibration, inspect the trench for danger signs.
Machinery and Plant:	Keep all plant and machinery well back from edges of the trench. Strengthen shoring if vibration is likely to cause the trench to collapse.
Intersecting Trenches:	Install extra shoring where trenches intersect. Close shore if necessary.
Lack of/Inadequate Shoring:	Install adequate shoring and ensure it is installed correctly.
Hazardous Atmospheres:	Ensure exhaust fumes of plant and machinery do not enter the trench. Check the atmosphere with a gas detector if doubtful of air quality, ventilate mechanically if required.
Soiled and Material Near Trench Edges:	Keep soil and materials a minimum of 600mm from edge of trench. Install spill boards. Chock pipe with edges.
Vermin:	Clear all underbrush. Visually inspect all trenches before entering. Plug all pipe openings when completed each day.

Follow Traffic Management Plans

Every project should have a Traffic Management Plan incorporated into the overall plan. It is your responsibility to find it, read and understand it and implement it into your work. If you are unsure about any of the content, you will need to seek clarification from your supervisor.

Form sample - [TMP](#)

Conduct machine preoperational checks

[Form sample- Plant pre-start](#)

Video - [Plant - pre-start](#)

Video - [Plant - tyre safety](#)

A Plant condition report should be undertaken at least monthly and when a machine is moved from site to site. When a machine is serviced a condition report should be completed by the operator prior to the service, a copy provided to the mechanic for his information and upon its return

Form sample - [Plant condition report](#)

Guarding/Failsafe Devices

Machine guards must be installed at all times and must not be removed, modified or made inoperable unless the machine is taken out of service or rendered inoperable by tag out. The machine must not be returned to service until guards are reinstalled and their correct operation is verified.

All machines must be of “Fail Safe Design” to ensure that in case of failure, power failure, and emergency stop or misuse that they become safe.

Video - [Plant - Machinery guarding](#)

Operator Protection Bars (ROPS/ FOPS)

The operator protection bars roll over protection (ROPS) and falling objects protective structure (FOPS) are designed to provide operator crush protection in the event of the excavator tipping or rolling over by controlled bending of the structural members.

Safety bars, props and pins

These are used to prevent the sudden collapse of parts of the Excavator if a lever is moved.

Operator responsibilities

At first glance, it would seem that the driver/operator’s role is simply to drive or operate the machine. However, this approach ignores some other important aspects of the operator’s job. The following list provides some of the other functions an operator may need to fulfil. Those functions include:

- Walk around checks and pre-start inspections;
- Fluid/lubricant/fuel refills (servicing);
- Defect reporting;
- Selecting the correct equipment for the job;
- Operating the equipment safely and productively;
- Operating the equipment with due care so as not to reduce its service life or cause unnecessary damage to it or other equipment;
- Parking equipment safely in designated areas;
- Observing the correct shutdown procedures;
- Ensuring that the equipment is available for use whenever it is next required;
- Ensuring that preventative maintenance (PM) is carried out when it is due;
- [Refer to housekeeping.](#)

If the operator can contribute to these aspects, then a high standard of vehicle and mobile equipment operations will be maintained throughout the site.

Video - [Mobile Crane Failures: Why Maintenance and Inspections Are Critical](#)

Fire-fighting procedures

Equipment engaged in heavy duty operating on around-the-clock basis spends most of its time at the high range of operating temperatures. Although machine fires are a rare occurrence, they can be responsible for total machine destruction, if not brought under control quickly.

Equipment fires often spread quicker than most fires, because the heat of the motor and transmission greatly encourages ignition. The tendency of operators in a fire situation is to “abandon ship” immediately. Instead, please follow the steps listed below to minimise operator harm.

If you suspect a fire (i.e. can smell or see smoke) Stop immediately. Lower attachments to the ground (in a fire the hydraulic hoses will perish, and hydraulic pressure will be lost resulting in attachments dropping to the ground).

Apply park brake and turn off the engine, Shut down the engine.

If you are able to exit the machine:

Exit machine, taking the fire extinguisher with you and investigate the cause of the smoke; If there is an engine fire, be aware that opening the rear door to access the fire will provide more oxygen and increase the (if no fire, report the cause of the smoke to your supervisor); Try to gain another operators attention in order for them to report the fire and then stand ready with a handheld extinguisher until assistance arrives.

If you are unable to exit the machine:

Shut the machine down completely as this step alone will prevent the engine fan from fanning the fire. The fan can quickly spread the fire. Another factor is the delivery of fuel and oil under pressure to the engine;

Continuously sounding the horn to alert attention and gain assistance Skid steer loaders rarely contain two –way radios due to the high level of noise in the cabin making them unusable for the operator

Remove the handheld extinguisher from the holder and use it, provided it is safe to do so. The best alternative is often to use the extinguisher to clear a safe path to exit the machine rather than fighting the fire itself. The standard sized extinguisher contained within a skid steer will provide approximately 10 seconds of flame suppression. Once safely out continue to fight the fire if it is safe to do so. When the extinguisher(s) are exhausted and if the fire is still burning, move away from the machine until further assistance arrives.

Fire suppression systems

Manually activated type:

Contents	AFFF (Aqueous Film Forming Foam) plus water. The cylinder itself is pressurised by nitrogen, whereas the activating canister (below the activation knob) contains CO ₂ . Some machines have chemical powder systems.
Capacity	50 litres

Coverage	The system only controls a fire source in the engine compartments via ten (10) outlet valves. If the fire has started elsewhere or spread to another area of the machine, this will have to be controlled using handheld fire extinguishers.
----------	--

Fire suppression system operation

For machinery equipped with a fire suppression system, the following procedures will apply.

If the machine you are operating is on fire (i.e. can see flames):

- Pull over immediately and stop;
- Select neutral, apply park brake and turn wheels into the side of the road;
- Shut down the engine by switching off the key and emergency shutdown switch;
- Using the “Emergency Radio Procedure” to place an emergency call;
- Pull safety pin and strike the activation knob firmly on the fire suppression system.
- Exit the truck/machine and stand ready with a handheld extinguisher until further assistance arrives (Do not stand by if it is a tyre fire);
- Do not restart the engine until the machine has been inspected by a mechanic.

If you suspect a fire (i.e. can smell smoke or have been told your machine is on fire):

- Pull over immediately and stop;
- Select neutral, apply park brake and turn wheels into the side of the road;
- Shut down the engine;
- Exit truck/machine and investigate the cause of the smoke;
- If there is an engine fire, activate the fire suppression system using the ground access activator knob (if no fire, report the cause of the smoke to your supervisor);
- Try to gain another operators attention in order for them to report the fire and then stand ready with a handheld extinguisher until assistance arrives.

Out of service tags

Out of Service Tags are used to protect machinery and equipment rather than people. Out of Service Tags are found either on the ignition key, steering wheel or at the isolation switch on the front of the machine.

The tag indicates that the machinery may not be started or operated, as it is unsafe either due to the possibility of further damage being caused to the machine or it could cause an injury to the operator. The Out of Service Tag can only be removed by an authorised person i.e. fitter electrician.

As an operator, you must never operate a machine outside the guidelines of the tagging procedure. If you see a fault with the machine, place an out of service tag on the isolation switch, steering wheel or ignition key.

Only under direct instructions from the workshop supervisor/foreman may a machine be operated whilst an Out of Service Tag is in place, normally for the purpose of testing prior to the return to service of the machine.

[Video - Plant - Lockout Tag Out](#)

[Video - Plant - Isolating machinery when not in production](#)

Personal danger tags

- Personal Danger Tags are used to protect equipment as well as people. The Danger tag protects personnel working on the equipment and the operator;
- Personal Danger Tags should always be placed next to an out of Service Tag if personnel are commencing work in or around the machine. Follow any site-specific procedures;
- There should be a Danger Tag for each person working on the machine, so that each person is individually protected;
- If you find a Danger Tag has not been removed, do not start or operate that machine even if you have been instructed to do so;
- The person who has their name written on the Danger Tag is the only one who can remove it! Ensure you are aware of all tagging requirements;
- Removing someone else's Danger Tag may result in DISMISSAL.

Warning plates and labels

There are several warning signs and labels around your machine. It is your responsibility as the operator to keep these plates and labels clean, so the warning messages can be read clearly.

Video - [Plant - warning labels](#)

Burn prevention

Hot water, oil and hot components can and do cause injuries. Operators must not remove radiator, hydraulic or steering oil tank caps. These jobs should be carried out by workshop personnel only.

Operate machine

For operational instructions refer to separate machine guidelines

Video - [Mobile Equipment](#)

Check Ground Conditions

Before setting up the machine you will need to check the ground conditions within the work location to determine appropriate stabilising and safe working area requirements such as whether outriggers or packing are required i.e. if it has been raining then the ground may be soft and unstable for heavy vehicles and machinery .

Working Near Overhead Powerlines Including Service Lines

Elevated Work Platforms are frequently used for work in the proximity of power lines. All power lines within the working area need to be identified prior to commencing any task involving an Elevated Work Platform. Contact with power lines is often fatal.

When working near power lines you must at all times observe the specific, legislated exclusion zone/s. If work is going to be conducted within the exclusion zone, a competent person should be assigned the role of safety observer to signal and warn you if any part of the Elevated Work Platform comes closer than the specified safe distance from the power line. It is important to source the legislated exclusion zone/s before commencing your task.

Video - [A Guide to Power Line Safety](#)

[Training information](#) – safe distances from Powerlines

Using A Safety Observer

A safety observer should be used when operating within the minimum distances from live powerlines or if required by the SWMS or PC.

The safety observer for exclusion zones should:

- Be competent in observing, warning and communicating effectively
- Ability to use two-way radios to communicate
- Be aware of hazards and risks
- Be able to warn about approach to electrical apparatus
- Be able to stop the work if necessary

- Not be located in the Elevated Work Platform
- Be specifically designated the safety observer job and only that job.

Engineering Principles - Centre of Gravity (CG)

The centre of gravity (CG) of any object is the single point about which the object is balanced in all directions.

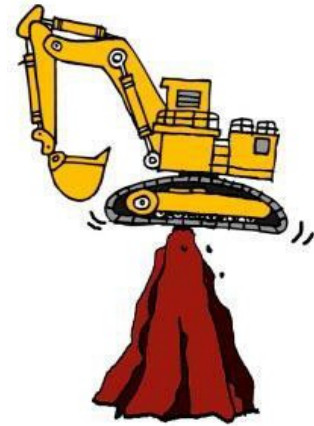

The stability of the Backhoe is determined by the location of the CG.

THE GOLDEN RULE that an operator MUST always follow is that they must control the centre of gravity.

Controlling the Centre of Gravity

Whilst operating a machine all operators should ask the question: “How will this affect my centre of gravity?”

When operating the excavator for good stability the operator must ensure that both tracks are in contact with the ground at all times. This will prevent excessive stress on the tracks and may prevent the machine from overturning.

Stability and controlling the centre of gravity is the mark of a GOOD OPERATOR.

Exclusion Zones

All fixed plant shall have a designated exclusion zone or safe work area that is allocated for the unobstructed use of the plant operator. This area will include a minimum distance of 1.000 metre from any moving part of the machine in all directions to ensure no other worker is within the distance that could allow injury by drawing in of clothes, limbs or hair. The exclusion zone should be denoted by highly visible lines on the floor. The exclusion zone must include sufficient space for the worker to rotate, flip or otherwise move materials being used.

A Risk Assessment should be undertaken to determine distances and to decide whether in some instances a rigid barrier (handrail) maybe required.

Video – [Plant - barricades and exclusion zones](#)

Video – [Plant - Struck by Mobile Equipment](#)

Video - [Plant - Forklift Invisible Pedestrian](#)

Blind spots

Due to the elevated position of the operator and physical features of the machine, visibility is limited and there are a number of “blind spots” around the equipment, as illustrated below.

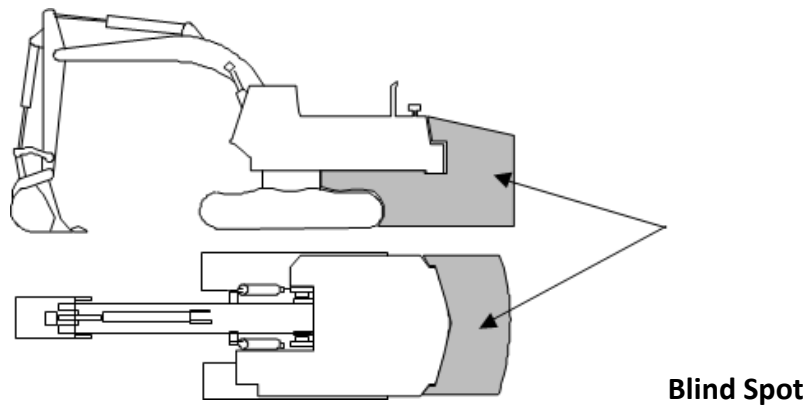

Fatalities and injuries have occurred when light vehicles and personnel are too close to heavy equipment. No light vehicle is permitted to park within 20 meters in front of or parallel to heavy equipment, without notifying the operator and receiving verbal confirmation. No light vehicle is permitted to park behind heavy equipment. When heavy equipment is parked behind other heavy equipment, you must notify the operator in front.

Video – [Plant - Field-of-Vision](#)

Vision impairments:

- Cabin pillars;
- Handrails;
- Rear view mirrors;
- Lube system grease canister;
- Fire suppression canister and extinguishers;
- Air reservoirs;

Access on and off the machine

Keep ladders, handrails and walkways free from grease, mud and other slip/trip hazards.

Maintain three (3) points of contact with the ladder at all times!

Video – [Plant - mounting and dismounting](#)

Horn signals

Whenever visibility is obscured or with personnel on foot or light vehicles may be in your vicinity, you are required to give warning signals using the horn prior to moving the machine.

Whenever visibility is obscured or with personnel on foot or light vehicles may be in your vicinity, you are required to give warning signals using the horn prior to moving the machine.

These horn signals should be used:

- At the go-line (machinery park up area);
- Around the workshop;
- At the fuel farm;
- On returning to the machine after a break (when starting a machine and moving);
- At any other time that visibility is obscured or there are personnel on foot or light vehicles in your vicinity.

Standard horn signals are:

- | | | |
|--------------|---|----------------------------|
| One blast | = | About to start the engine. |
| Two blasts | = | About to move forward. |
| Three blasts | = | About to move in reverse. |

Pause for at least five (5) seconds between the last horn signal and commencement of the appropriate action.

Guarding

Guarding must always remain in place

Video - [Plant - Machinery guarding](#)

Passengers

Passengers are not permitted to ride in or on any vehicle unless it is fitted with approved seating, approved seatbelts and access.

Restricted area

Access to blasting areas is strictly prohibited.

Vehicles are not to be driven onto a marked drill or drill sampling pattern unless authorised by appropriate supervisor. Access marked by hazard signs and danger tape is strictly prohibited.

Cause of Trench Collapse

- Neglect to install shoring/ground support.
- Inadequate or poorly applied shoring.
- Mechanical failure of soil to support its own weight.
- Breakdown of soil strength due to moisture.
- Vibration from vehicle and/or plant.
- Surcharge of spoil composition (Sand pockets etc.).
- Previously disturbing ground (Land fill, old trenches).
- Trench walls being struck by heavy loads.
- Undercutting.
- Premature removal of shoring.

Video - [Excavations: a Guide to Safe Work Practices](#)

Video - [Plant - Excavations Soil Instability](#)

Video - [Plant - Excavations Pre-Excavation Requirements](#)

Back Filling Trenches

When back filling, use a landscape bucket, since this will cover the full width of the machine adjust bucket angle for an accurate, acceptable finish.

The correct method is to have the bucket parallel to the ground. And always keep all four wheels in contact with the ground this reduces bucket wear, gives maximum traction and makes it easier to maintain a level surface. Operate loader at right-angles to the trench.

Do not take too big a bite or cut with the bucket. Fast, easy work is achieved if, when first contacting the soil, a cut only half the bucket width is taken. By the time the bucket reaches the trench sufficient additional soil will have spilled over the fill the remaining half of the bucket. Taking too big a cut can result in traction difficulties and lost output.

As a general rule, when back filling, do not push more soil than the loader can handle without wheel spin or increased engine speed. If for some reason, the speed of the loader is reduced, relieve the load by crowding the bucket and if this is not sufficient in itself to raise the loader beams slightly. When making trenches along hillsides always pile the soil on the uphill side of the trench. This will make subsequent back filling easier.

Stay Alert, Cave-Ins Can Be Hazardous

Use caution in back filling. Do not get too close to the trench wall. The combined weight of your equipment and the load could cause the trench wall to give way. Before back filling, see the manufacturer's operator manual.

When working under hazardous conditions, have a second man work with you to signal for dangers. Make certain he does not get too close to your loader.

Video - [Excavation Death Trap](#)

Smooth Controls And People Safety

- Make sure that all the controls of the machine are working correctly and that you understand which levers/pedals control different functions (refer to the operator's manual).
- When using the controls, keep all movements smooth and even to avoid any jerky movements.
- Be aware of anyone who is in the area while working on the job site.
- Before reversing the machine always look behind and make sure that the path is clear behind the machine before moving off.
- The safest place for people to be when the machine is working is well clear of the work area and if there is a need to be closer, they should be alert and be a distance of at least one and half times the length of the machine at all times.

Excavating And Levelling The Site

- Before excavating can start plan the job that is required to be done, and if the job site plan has been provided read it and understand it (check for underground services).
- As described before in this module remove the topsoil in layers and stockpile it as this will be required when back filling the excavation.

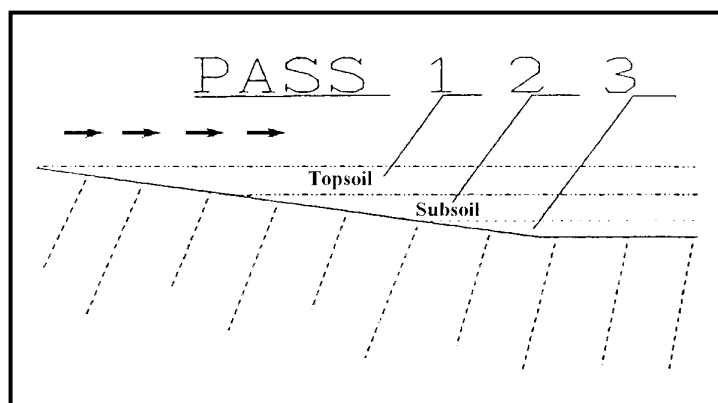

Figure 1 REMOVING TOPSOIL

- If the material that is being excavated is not required for back filling then the soil can be placed into a stockpile and removed at a later date, it would be better to have a haul trucks present and remove this material straight away.
- When the sub soil is reached, and all the topsoil is removed continue to remove the sub soil in layers.
- If when doing this the machine wheels start spinning reduce the depth of the cut.
- With the sub soil it can be placed half metre from the edge of the trench as per the site plan, or it can be loaded onto a haul truck
- Continue this method of excavating until the desired depth is required and it is within the industry's tolerances.
- While excavating, the depth must be checked at regular intervals. This is achieved by using a tape measure or a long-handled shovel which has been marked with a piece of electrical tape, at the right depth.

Video - [A Guide to Power Line Safety – Avoiding contact with underground services](#)

Video - [Underground Utilities](#)

Video - [Electrical Safety: Underground Contact](#)

Cut And Fill

Cut and fill is a common process for the levelling of a site. Put simply, the material is cut off the high points and placed into the low spots.

To do this the bucket is partially filled and tilted slightly forwards. The bucket will fill empty as it passes the high and low areas.

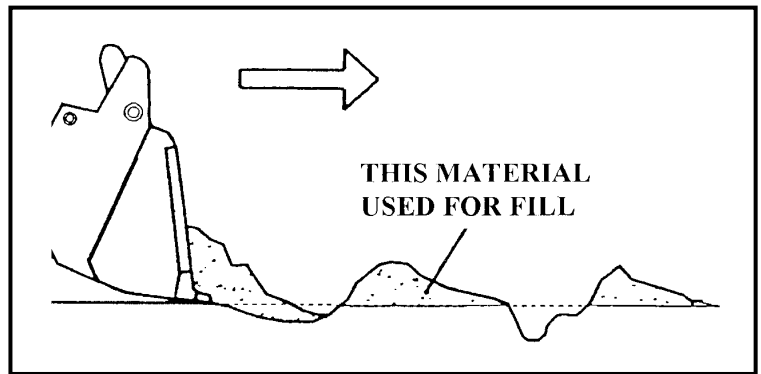

Figure 2 CUT AND FILL

If the fill does not fall freely from the bucket. This is best completed with the bucket in the fixed position.

Never try and do this in floating position as the bucket will dig in and bog the unit.

Video - [Plant - Excavations Introduction](#)

Video - [Plant - Underground Utilities](#)

Video - [Plant - Utilities](#)

Back blading

The term back blading is given to the technique of using the bottom and back of the base edge on the bucket while moving backwards.

This method is used to spread material evenly across a given area.

The bucket load of material is dumped, and the Machine moved forward until the bucket is forward of the heap. The bucket is then tilted forward to around 45°. The boom arms are lowered until contact is made with the material.

The machine is then reversed dragging the material with it as it reverses.

The bucket can be rolled back to control the depth and level of the spread allowing a smooth tapered finish.

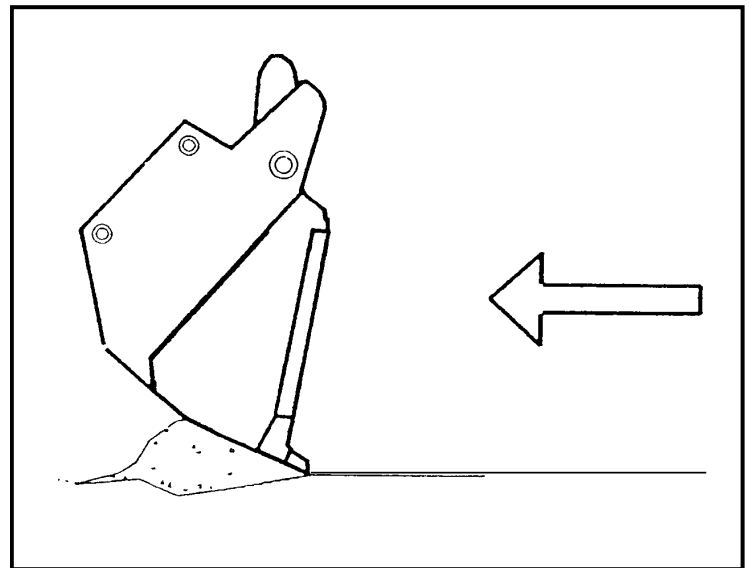

Figure 3 BACK BLADING

Rolling the bucket may produce smoother more controllable action than raising or lowering.

In general terms the operators must assess the conditions and the soil type and adjust the bucket to suit.

The bucket will give a level finish if the control lever is left in the neutral position or it will follow the contours of the ground if it is placed in the floating position.

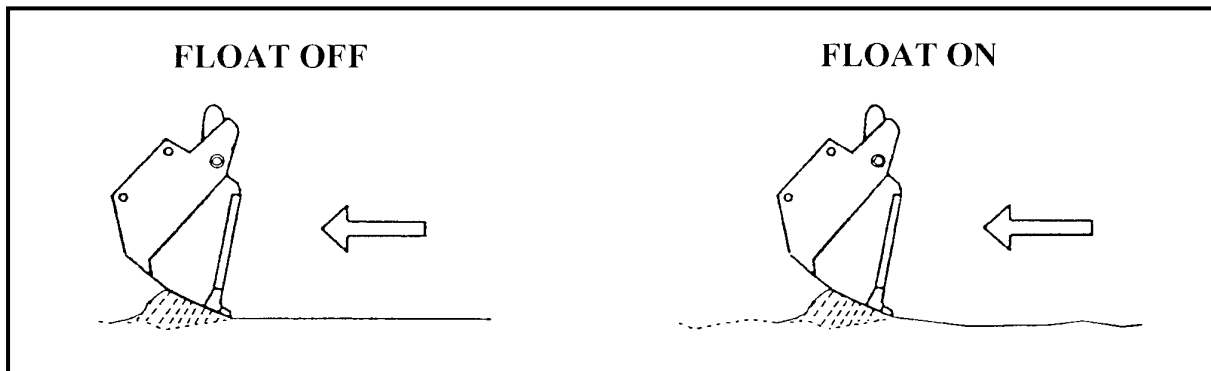

Figure 4 USING BUCKET IN FLOAT POSITION

Precautions For Working On Inclines

Working on inclines ground with a machine needs extra care and planning. The reason for this is in the weight distribution of the machine and the fact that the machines characteristics can be altered by raising and lowering the bucket assembly.

The general skid steer loader unit has a weight distribution of around 66% mainframe and 33% bucket assembly and this 33% of movable weight is the cause of concern.

As the bucket assembly and load are raised the centre of gravity of the machine is also raised. On level ground this increase in the height of the centre of gravity is only noticed when turning or braking. However on a slope this increase in the height of centre of gravity causes the machine to become top heavy and easily toppled.

Working On Inclines, Grades and Banks

- Work from a level surface wherever possible. If not possible, then make sure you have a flat area for safe turning, loading and unloading.
- When travelling with an empty bucket on an incline always have the rear end of your machine pointed uphill. Always Backup and Drive Down inclines. Approximately 70% of the weight is on the rear when the bucket is empty.
- Always have a loaded bucket uphill of the machine when travelling up or down inclines.
- Travelling slowly down inclines to maximize engine braking and minimised the need for brake operation. To reduce speed when travelling down an incline decrease the forward pressure applied to the travel control lever(s).
- Avoid making any turns while travelling across inclines. If unavoidable make sure the Centre of gravity of the machine is as low as possible and take care not to make any sudden changes in speed or direction.
- Check soil conditions when working on banks. Slides and cave-ins are a real hazard. Shore and brace as required.
- Watch for loose material while working on inclines as the machine may slide and be placed in a dangerous position.
- When working near ditches or trenches on inclines extra care must be taken to avoid the weight of the equipment causing a slide or cave-in.

Driving Up And Down Slopes

Always travel uphill or downhill with a full bucket with the bucket on the uphill side.

With an empty bucket, travel with the rear of the machine facing uphill.

The centre of gravity of your machine shifts as loads are lifted and lowered. Never attempt to make sharp turns or travel on steep slopes with a raised load. Make sure you can see where you are going. Never travel with a load obstructing your vision.

Video - [Plant - operation on slopes](#)

Lift, carry and place materials

Video - Plant - safely-lift-with-equipment

Video – [Plant - Chains and slings](#)

Night-time operating rules and tips

When driving in the pit at night excavators must be equipped with effective headlights.

Avoid looking directly into the glare of headlights from oncoming traffic.

Refer to SWMS

- loading trucks from a stockpile;
- correct load distribution; and
- travelling with a full bucket.

Techniques For Travelling With A Full Bucket

When travelling with a full bucket there are a number of points to remember:

Carry the loaded bucket as low as possible, at all times, for best visibility and stability. Only raise the bucket just prior to discharge of the load.

- Avoid sudden starts, stops or changes in direction.
- Always operate the machine controls as smoothly as practical.
- Never travel with the bucket load obstructing your vision.

Public Roads

Before you drive on a public road you must have the correct licence, registration and insurance for the machine you are about to drive. Machine should be roadworthy e.g. Head and taillights, indicators etc. Check with your state authorities for the relevant licence, registration and insurance requirements.

Video - [Plant - Toolbox - Driving Safety](#)

On Rough Terrain

Always travel slowly when working on rough terrain. Any high-speed travel is likely to make the machine become very unstable, due to tyre bounce, and cause tyre damage and loss of control. High speed travel over rough terrain also caused rapid operator fatigue.

Stockpiling

A stockpile is a quantity of material which has been heaped up for storage, for use at some later date. The size and shape of the stockpile will vary according to the material type, position on site, ground conditions, weather conditions and amount of material to be stockpiled.

Small stockpiles are generally referred to as HEAPS and long thin stockpiles are generally referred to as WINDROWS.

A small windrow is also known as a wall and as you can imagine it is simply a single row of heaps placed to form a wall of material.

The following is a general procedure for forming stockpile. Each site will require some degree of change in the procedure; the outline however will remain the same. Depending on circumstances and local conditions the stockpile site, stockpiling procedure, ramp position, number of ramps etc. may vary.

In all cases damage to machine, ramp approaches, work area and best productivity should be considered when determining the best approach.

Site Inspection: Inspect the site to determine the best location for the stockpile, consider the following points when making that decision.

- Ensure clear access to and from the stockpile. Remember that the access may change as the site develops.
- Distance from stockpile to the excavation should be less than 50m if possible, this reduces the turnaround time involved.
- Does the stockpile site require any modification prior to stockpiling beginning i.e. the clearing of rubbish etc.?

Forming the Stockpile: This involves the moving of the material to the designated stockpiling point.

- The material should be moved to the boundary corner of the stockpile area that is furthest away from the excavation.
- Some care should be taken to place the material short of boundaries as it is likely that some of the material will overflow or slump to the boundary.

Make sure that the survey and/or set out pegs are not disturbed while operating the machine. Allow for rain - working of soil.

Techniques For Loading Trucks

The operator has control of the trucks as well as the loader when loading trucks from a stockpile. The operator should instruct the truck driver as to exactly where the truck should be placed. By doing so the operator should aim to keep the length of the run between the truck and the stockpile or bank as short as possible.

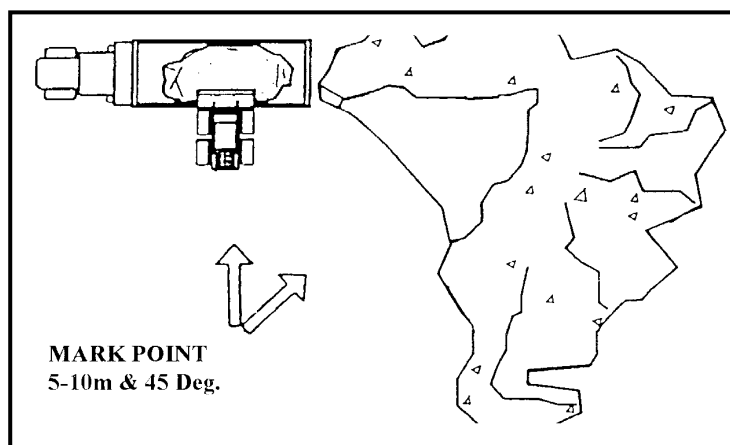

Figure 5 LOADING FROM A STOCKPILE

For faster loading maintain a 45°-turn angle (this is known as V loading) and mark as close to the vehicle as possible. (See diagram for relative position of the mark point). The loader should not have to travel more than 5 to 10 metres each way to achieve a load.

Raise the bucket just prior to reaching the truck. After discharging the load, lower the bucket immediately after the loader is clear of the truck. Be sure to keep the bucket level as it is being raised otherwise material will fall over the rear of the bucket into the operator's lap. Always keep the working area clean, especially when loading hard coarse materials such as broken rock, brick rubble, or broken concrete.

This not only speeds up the loading cycle, by providing a smooth work surface, but also saves wear and damage to the loader tyres.

Always remove any ruts as they appear, this can be achieved by simply removing split material from the floor and filling in any rough areas during any free time.

Video - [Preventing workers falling from trucks](#)

Video - [Working in and around mobile plant](#)

Video - [Safely securing loads of trucks](#)

Video - [Fly Rock from Blasting It was raining rocks!](#)

Correct Load Distribution

Care should always be taken with the placement of material into the vehicle body. The driver should indicate where he/she wishes the major weight distribution to be placed (over the drive or trailing axles).

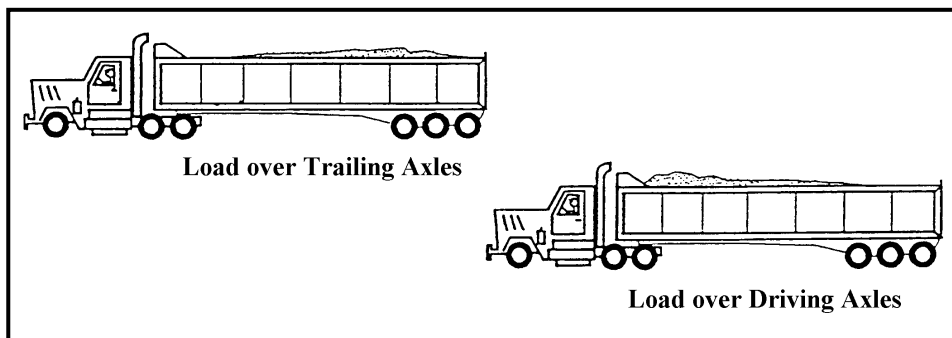

Figure 6 DISTRIBUTING THE LOAD

Dumping Load into a Truck

- Raise loaded bucket high enough to clear side of truck. Be certain to level load, with tilt control as bucket is being raised. Levelling load will eliminate possibility of any material falling from back of bucket.
- Press toe of tilt control and dump bucket.
- If the entire load is being dumped on the near side of the truck it can be pushed to the far side using tilt control pedal.

Overhead guards are installed for your protection. Do not operate the machine with overhead guard removed.

Align the bucket with the centre of the truck, raise the bucket to clear the truck body, and commence dumping the material.

If necessary, shake the bucket to dislodge any stuck material. Spread the material as you go instead of just dumping on top.

Work from the cabin to the tailgate. By dumping through the pile you can spread and dump at the same time. To do this lower the bucket and as it is dumped the material behind the bucket is spread towards the machine. (Step 3 Figure 74).

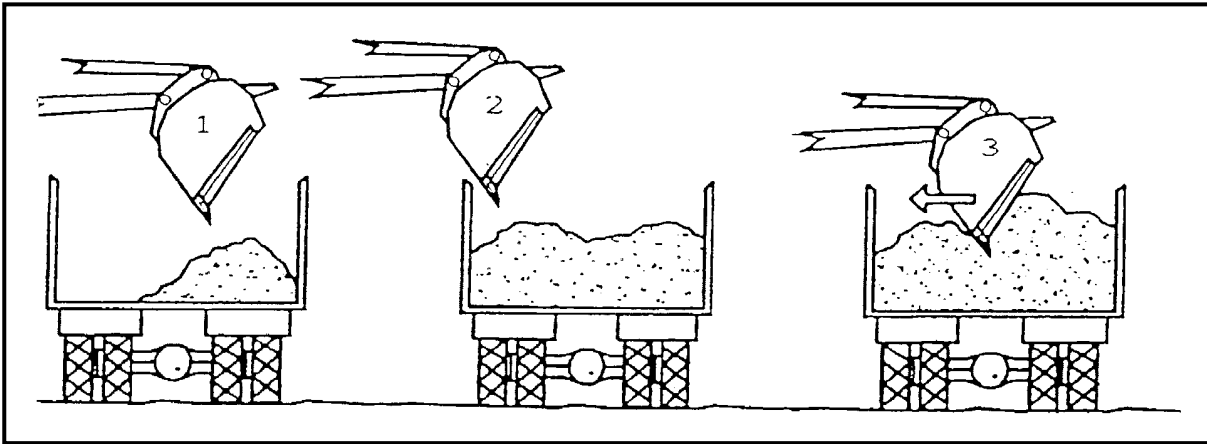

Figure 7 LOADING TECHNIQUES

Operators should be aware of the limitations of truck loading with a machine particularly regarding safety and damage to both machines and trucks. If the material is heavy and rough it should not be dumped but rather placed into the vehicle. Rocks can be cushioned by placing a bucket of fines (sand sized material) in the vehicle first.

Checklist for the Loading of Trucks

- Position truck to achieve effective safe loading.
- Keep the turning circle to a minimum.
- Maintain a clean, clear work floor.
- Approach loading face at right angles.
- Use crowd and lift to maximise the break-out force.
- Approach truck at right angle.
- Raise bucket preparing to dump as you approach the truck.
- Always travel with your bucket low.
- Use correct dumping procedures for truck loading:
 - first load placed;
 - body loaded evenly; and
 - truck loaded to, but not beyond, legal limit.
- Reposition bucket to the load position as you back away from the truck and return to the face for the next load.
- Avoid loading into the wind where possible, have it at your back. Do not load downhill.

Select, remove and fit attachments

Machines have a large range of attachments that can be fitted to improve productivity of the machine on specific job applications.

Refer to operator's manual for the correct way hook up and remove special attachments that are to be used.

Quick Release couplings are a versatile and quick method of securing attachments.

Different types of machines have different switches and controls for operating the attachments, so refer to operator's manual on how to load up the hydraulic system to drive the attachments.

[Video - Plant - attachments](#)

[Video - Plant - Quick-coupler](#)

Different Attachments And Their Uses

	<p>A wide range of Breakers will be available for your machine all designed for perfect compatibility and long life. A variety of tools are available to maximise the versatility and productivity of this reliable attachment.</p>
	<p>This quick-change attachment was conceived with the farmer in mind and is ideal for handling manure and silage. The optional top grab allows you to covert to fork only operations for speedy loading and sorting application</p>

Figure 8 ATTACHMENTS

Fitting And Removal Of Attachments

- Before changing attachments, the area has to be clear of any obstacles and flat.
- Drive the Machine up to the attachment with the coupler lock levers in the unlocked position, (in the vertical position refer to operator's manual)
- Drive forward and roll the top edge of the coupler lip down with the bucket control lever/pedal until it is located under the lip of the attachment that is required for the job.
- Lift the loader arms up slightly to ensure that the attachment has been picked up.
- Rotate the coupler back until the face of the coupler is flat on the face of the attachment.
- Lock the coupler levers in the horizontal position.
- If the attachment has hydraulic hoses on it connect them up refer to operator's manual.
- Ensure the attachment is now surely connected by placing it on the ground and apply a little down pressure on it with loader arms and bucket controls.

To remove an attachment, reverse this procedure.

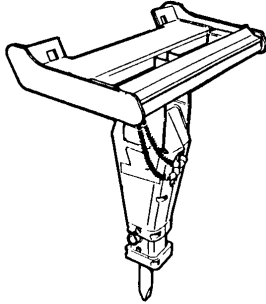
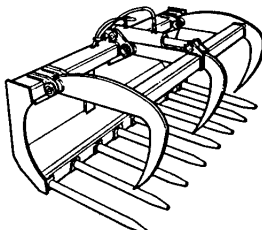
Relocate the machine

Ensure machine is cleaned to site requirements considering pest & weed restrictions both on this and the next site. Load machine safely ensuring not to interfere with traffic . Machine to be floated on an appropriate truck

If the machine has to be relocated to another worksite all road rules and site regulations need to be adhered to. Before undertaking the task of relocating the machine you should look out for other vehicles and pedestrians, Know your clearance heights, Travel at a safe slow speed, Follow all site rules

[Video - Loading and unloading mobile plant](#)

Video - [Managing your drivers' safety at delivery points](#)

Video - [A Guide to Power Line Safety – Contact with a power line](#)

Video - [Plant - Toolbox - Moving Vehicles](#)

Video - [Plant -Moving around safely during loading](#)

Carry out machine operator maintenance

All plant shall be regularly serviced and maintained in accordance with manufacturers' recommendations. Maintenance schedules should be established (to manufacturers specifications) that determine frequency of servicing and provide a checklist of items requiring inspection, testing or repair, lubrication or adjustment.

The procedures relating to refuelling and servicing of excavators will vary from site to site only in regard to time and place of servicing.

In all cases the following procedures MUST be observed:

- Approach fuel farm or service truck at a maximum speed of 10 km/hr;
- Idle into the refueling position;
- Observe guidance signals from the serviceman;
- Select neutral, apply park brake and leave the engine running;
- The attachment must be grounded and the control/servo lock and slew brake applied before the service truck can approach the excavator;
- Exit cab and climb off the excavator.

When being refuelled it is imperative that you remember that you;

- Are in a No Smoking area (i.e. Do not smoke);
- Do not get back on the excavator until all out of service tags and danger tags have been removed.

If refuelling is carried out during the shift, take the opportunity to inspect the excavator (if allowed to do so) – things do come loose during operation

Clean up

Refer to SWMS requirements

[Refer to housekeeping](#)

Operate Skid steer loader Guidelines



Safe Operation of Plant

Refer to [Hazard Identification](#) for information on Safe operation

Refer to General Plant operations for Safety requirements for the operation of Plant
[Training information](#)

Pre-start checks **form sample** - [Plant pre-start](#)

Video – [Plant - Bobcat](#)

Skid steer Loader Characteristics

Front-end loaders of the skid steer type are:

Self-propelled wheeled machine in which steering is accomplished by skidding or reversing the wheels on one side of the machine. Also with an integral front mounted bucket-supporting structure and linkages, which loads or excavates through forward motion of the machine, and lifts, transports and discharges material.

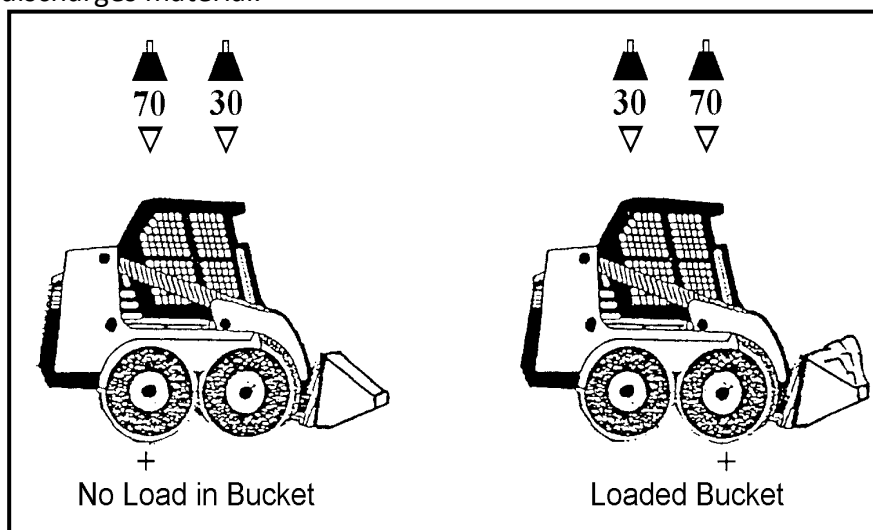

Figure 9 WEIGHT DISTRIBUTION

The primary advantages of this type of loader over others are its size and its manoeuvrability because they can turn within their own length.

The smaller machines are largely used in domestic situations, such as landscaping and driveways. Whereas the larger machines are used in industrial capacities, quite often with a variety of attachments e.g. back-hoes, planners, brooms and four in one buckets.

Weight distribution and balance are other ingredients that add to the design recipe for stability and turning capacity. The skid steer loaders are designed with unequal loading between the front and rear axles.

With no load on the bucket, about 70% of the machine's weight is on the rear axles, the machine easily pivots or turns on the rear wheels.

With a load in the bucket, the ratio reverses, most of the load is now on the front axles, now become the pivot point for turning.

Controls For Skid Steer Loaders

Most have two directional control levers which are used to perform the forward travel, reverse travel, and turning function of the loader. Push both levers full forward to go forward (Figure 5a) - pull backward to reverse (Figure 5b). Neutral position is midway between forward and reverse positions.

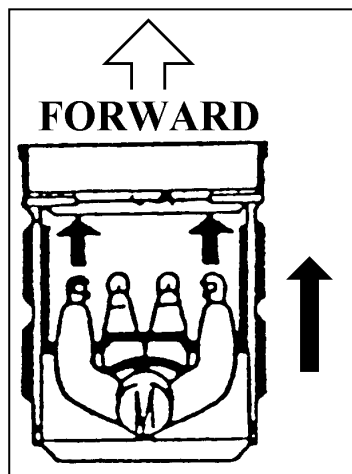

Figure 10 SKIDSTEER LOADER CONTROLS -FORWARD

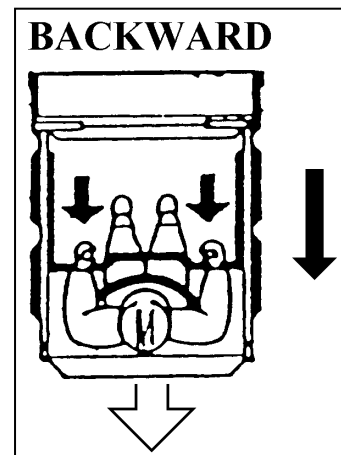

Figure 11 SKIDSTEER LOADER CONTROLS -REVERSE

Turning Controls

Moving one lever further from neutral than the other will result in a smooth wide turn. Pulling one lever back and pushing the other forward will result in the loader pivoting in "its own tracks".

- New models from some manufacturers have a variation of these controls
- Both the forward reverse and turning are controlled by one joystick (Figure 7).

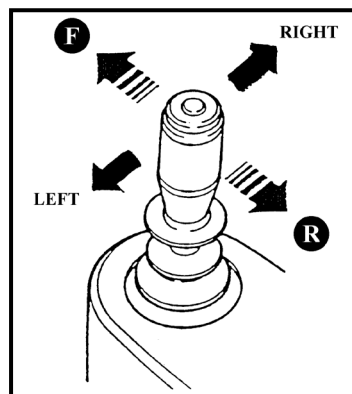

Figure 12 JOYSTICK CONTROLS

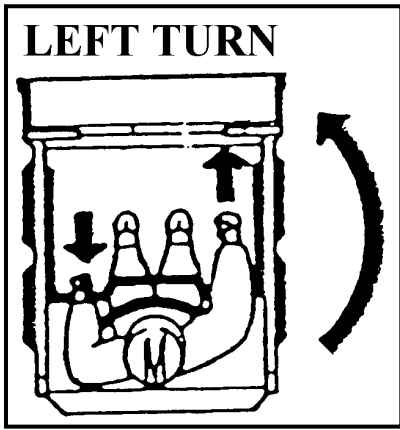

Figure 13 SKIDSTEER LOADER CONTROLS - LEFT TURNS

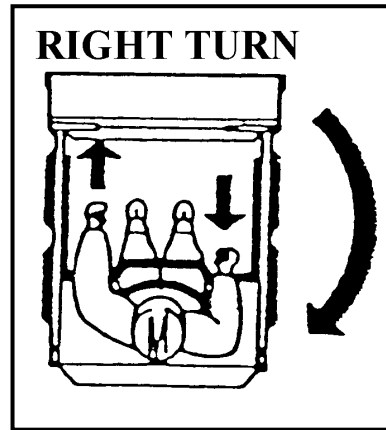

Figure 14 SKIDSTEER LOADER CONTROLS -RIGHT TURNS

Bucket Controls

- The bucket controls are either floor pedals or hand controls

Foot Controls

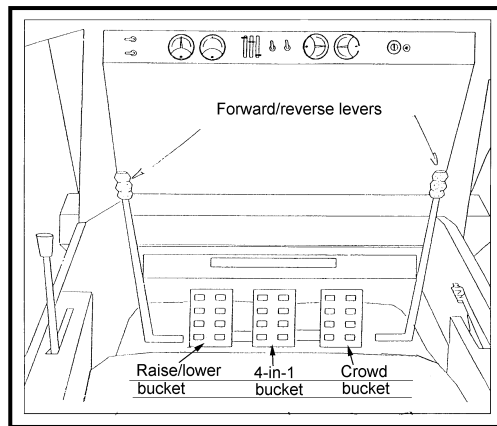

Figure 15 BUCKET CONTROLS (FOOT)

Hand Controls

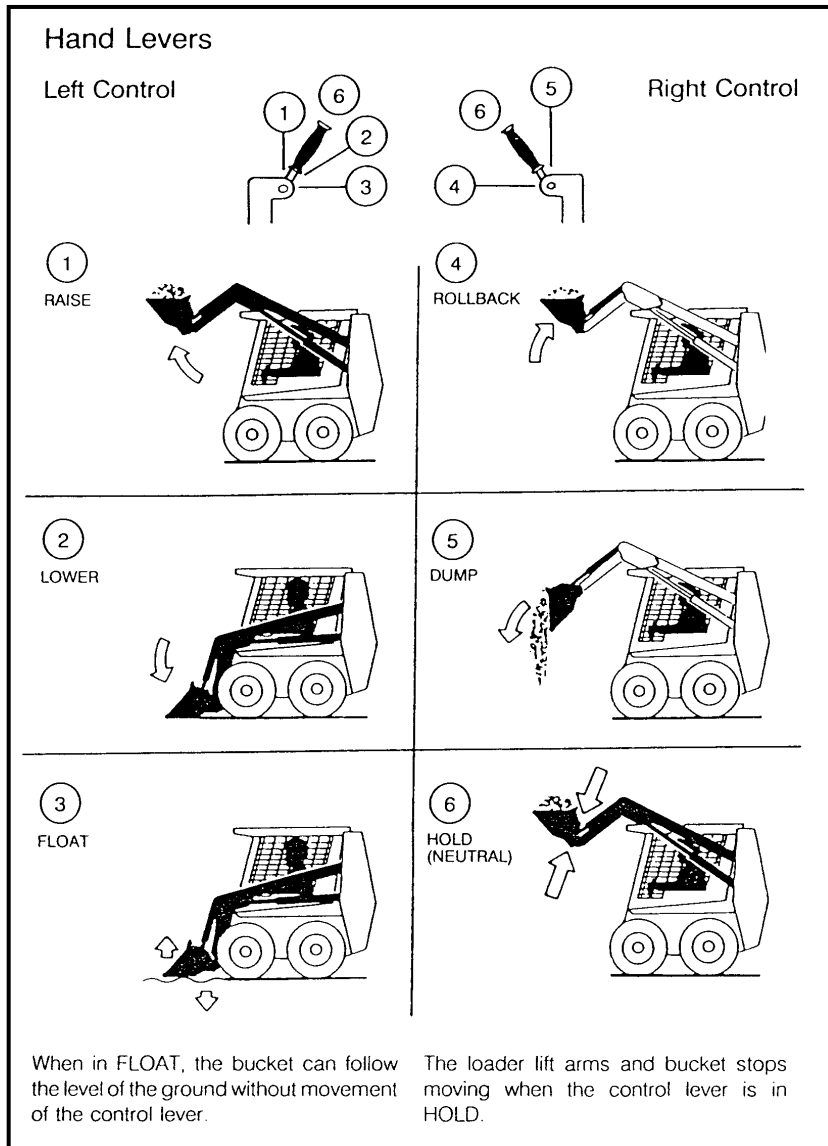

Figure 16 LOADER CONTROLS (HAND)

Loader Arm/Shovel Control Lever

Some new models now have the bucket controls on one joystick.

Loader A controls the movement of the loader arm and the shovel (or any other attachment which is installed on the loader arm).

The lever has four main movements and is spring loaded to its central (hold) position.

The speed of loader/shovel movement depends on how far you move the lever; the further you move the lever the faster the action.

The main lever movements are shown right. Their effects are described below. Combined actions can be achieved by moving the lever diagonally. The lever movements are resulting actions and shown on a decal on the cab front wall.

1. To raise the loader arm pull the lever back.
2. To lower the loader arm, push the lever forward.
3. To roll the shovel forward (dump), push the lever to the right.
4. To roll the shovel back (crowd), push the lever to the left.

Driver Protection Bar

The driver protection bar or SKI BAR is a bar or pair of bars that must be lowered to a position in front of the drivers waist.

This bar is designed to prevent the operator from getting out of the machine or into a position where there is danger from the attachments.

The bar must be in the lowered position for the controls to function.

Each brand of loader has its own design of these controls, some may only have one fitted, some may have a combination, others may have all.

Operator Techniques

Operating Loader with Bucket

To fill bucket from a stockpile:

1. Place lip (cutting edge) of bucket on the ground. Drive forward to fill bucket.
2. Slightly raise loader arms as soil enters the bucket to break any resistance
3. Roll the bucket back as it fills while at the same time slowly raising the bucket arms.
4. When the bucket is filled, back away from pile and lower the bucket to a safe working height.
5. Keep bucket low while moving to dumping area.

To Dig Into Hard Ground

1. Tilt bucket down until it contacts the ground.
2. Drive forward, tilting bucket as necessary to penetrate surface.
3. Roll back bucket slightly to decrease bite, increase transaction, and maintain uniform depth.
4. Continue driving forward until the bucket is tilted. Roll back bucket and proceed to the dumping area.

Levelling and Back Filling With Bucket

1. To spread fill, drive forward with bucket raised and tilted down enough to allow material to slide out slowly.
2. To level, drive backward with bucket raised and tilted down spreading material evenly.

NOTE: Float position on lift controls work well on some levelling jobs. This allows the bucket to follow uneven ground.

Excavating With the Front Bucket

Mark out the trench by placing off set pegs at half a metre away from the side of the proposed trench to be excavated.

Start this operation by making a sharp-angled cut into the ground some 7-8cm deep and break out cleanly.

This provides a step into which the leading edge of the bucket can be driven to achieve the required degree of penetration when commencing the first and subsequent stripping runs. Angle bucket so that the bottom is level with the ground and make the first run about 7-8cm deep.

Use the bucket rams to vary the pitch of the bucket to maintain the bucket as its correct depth. Remove layers of the soil and stockpile if far enough away from the site.

When excavating a trench a ramp will be required at one end of the trench (the ramp should be a 1 to 10 ratio).

To avoid wheel spin of the front-end loader reduces the depth of the cut.

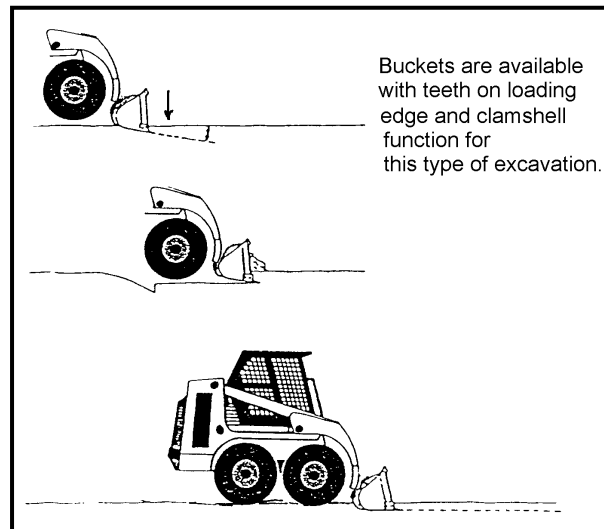

Figure 17 EXCAVATING WITH FRONT BUCKET

Continue this procedure until the required depth is obtained.

If the trench goes below a depth of 1.5 metres from existing ground level. The sides of the excavation will need to be battered or shored.

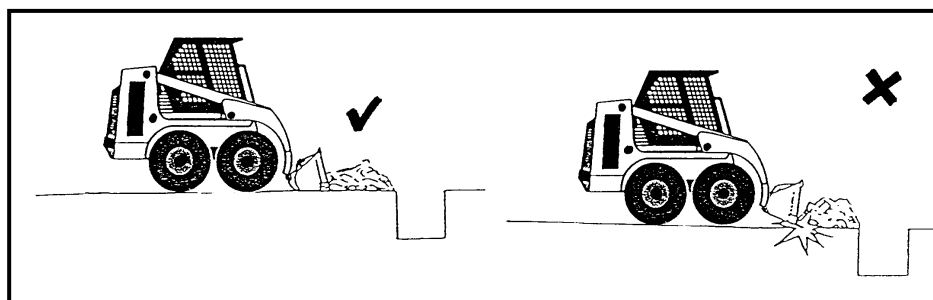

Figure 18 BACKFILL A TRENCH

Smooth Operation Of The Bucket

- Rather than jerky movements, smooth operation enables more efficiency and will speed up the operation of the machine.
- This also assists in less wear and tear on the machine, as well as less fatigue on the operator.
- The operator can 'feather' the controls (operate the controls with very small movements).
- Note: Slow, easy movements.
- Approach the stockpile with the bucket flat on the ground and move slowly into the heap rolling the bucket back towards the machine and lift the loader arms up at the same time, so that the bucket has a peeling effect on the face of the stockpile.

- When the bucket is full gentle shake of the excess from the bucket. This will keep the floor in the travel area clean and give the operator a smoother ride.
- With the bucket low to the ground proceed to the dump site and load or stockpile the material.

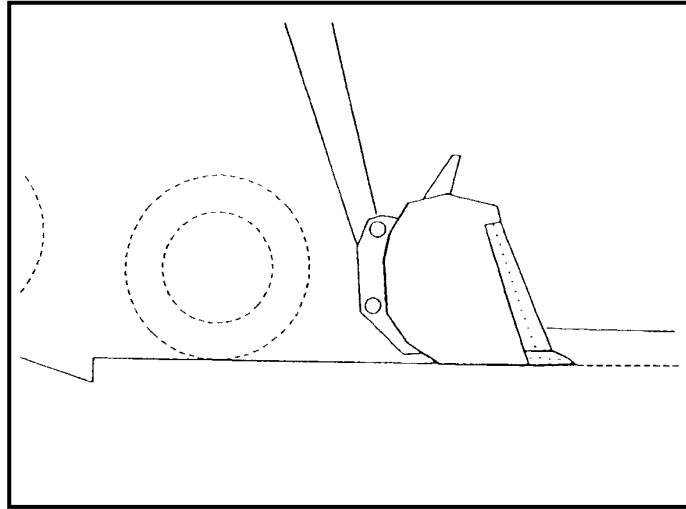

Figure 19 REGULATE DEPTH OF CUT WITH BUCKET CROWD

Once the cut has been started, roll the bucket back to the level position and at the same time lower the loader arms to maintain the cut. While cutting, the soil under the bucket should be monitored to ensure that only the topsoil is being removed and there is as little removal of subsoil as possible. The boom may need adjustment to allow for the machine angle change as it moves into the excavation.

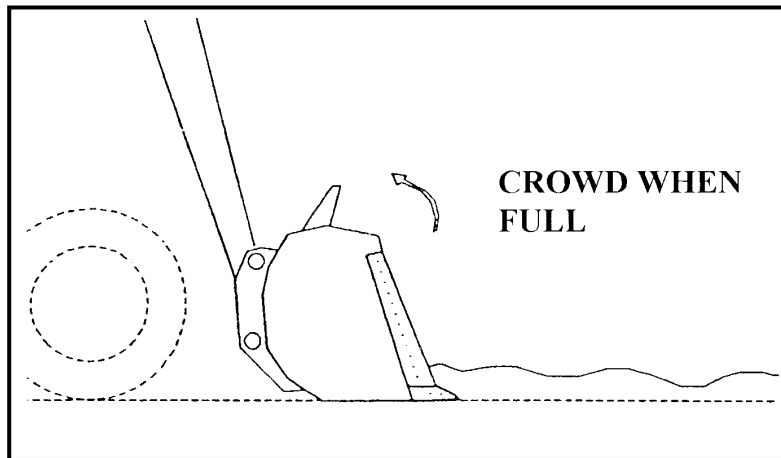

Figure 20 CROWD BUCKET TO FILL

When the bucket is full at the end of the run fully crowd the bucket to prevent soil spillage. It may not always be possible to fill the bucket - monitor the spillage from side of the bucket.

Operate Excavator Guidelines



Safe Operation of Plant

Refer to [Hazard Identification](#) for information on Safe operation

Refer to General Plant operations for Safety requirements for the operation of Plant

[Training information](#)

Pre-start checks **form sample** - [Plant pre-start](#)

Video - [Plant - Excavator](#)

Video - [Electrical exclusion zones](#)

Track frame or undercarriage

The undercarriage is a self-travelling structure that consists of:

- rubber or steel tracks
- drive sprockets
- drive motors
- turn table / swing circle
- rollers
- idlers
- and associated components/structures

The undercarriage supports the house structure and the workgroup. The undercarriage of the excavator is highlighted on the below diagram.

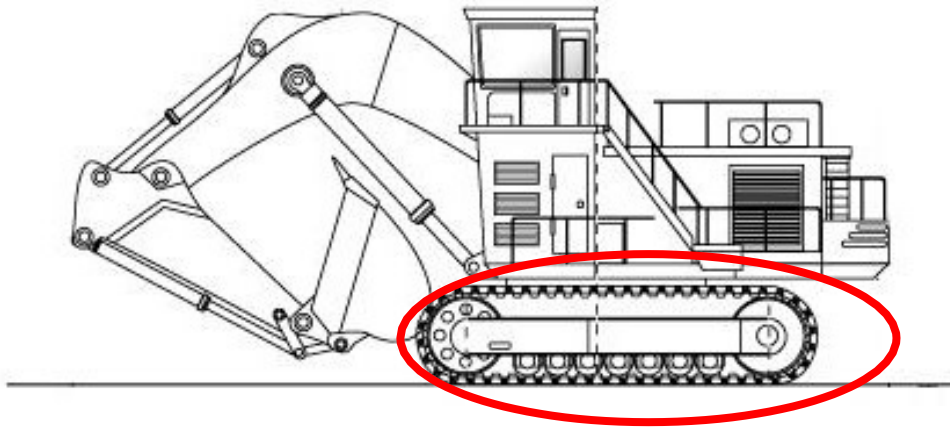

Superstructure

The superstructure is a platform that is able to rotate by 360 degrees on a vertical axis and is mounted on the undercarriage turn table. The superstructure is a system of girders and beams and serves as the support for the boom, walking mechanism, and other components. It consists of the:

- Car body;
- Engine;
- Work group;
- Cab;
- And the house structure.

The superstructure is highlighted on the below diagram.

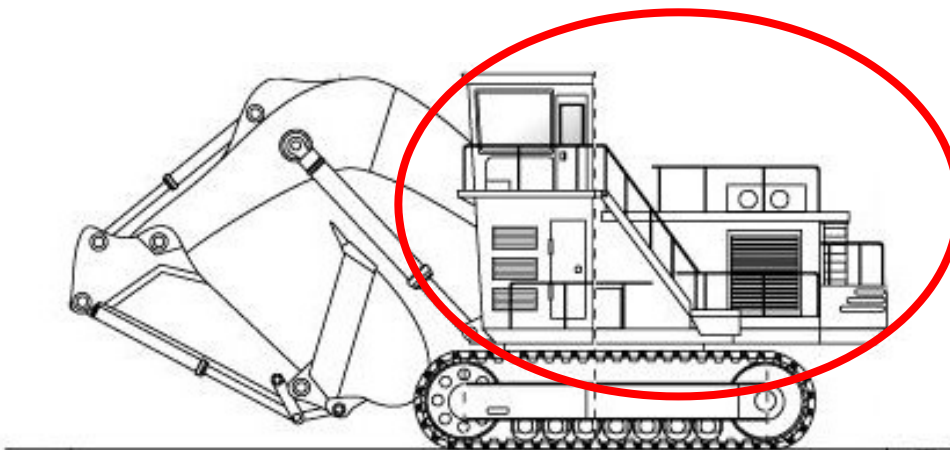

Boom, stick and bucket

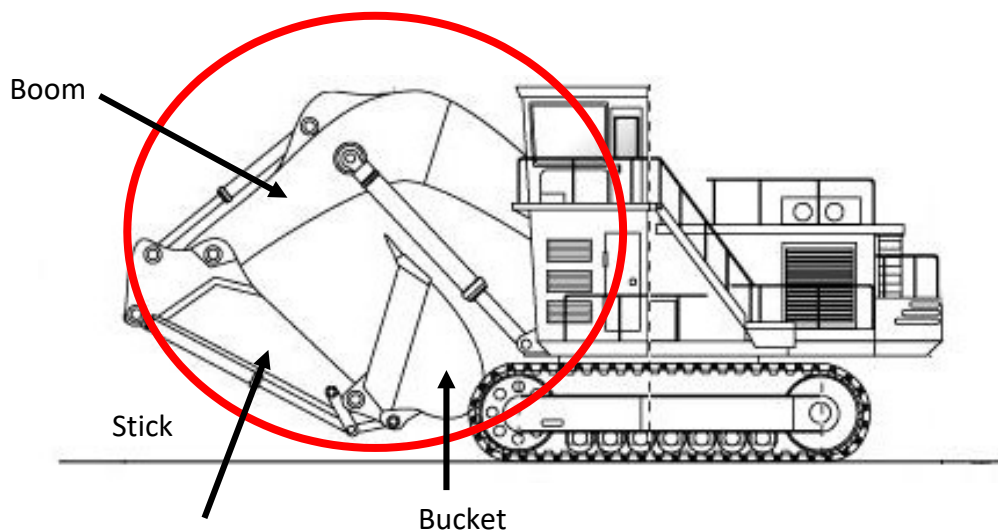

Daily Procedures

Machine boarding and dismounting

Never become complacent when boarding or dismounting a machine. Many injuries have occurred in the past as a result of boarding or dismounting a machine incorrectly.

When boarding or dismounting a machine you must:

- Clean your shoes and wipe your hands before climbing;
- Use handrails, grab-irons, ladders or steps when mounting;
- Never use controls as grab-irons;
- Never board a moving machine;
- Use three points of contact at all times;

Climb or descend the ladder safely and sensibly;
Always ensure you understand the horn signals for your site.



Excavator Components

Electronic Monitoring System (EMS)

Most excavators have some sort of electronic monitoring system, but the system may vary from machine to machine.

Some excavators have a test function for the EMS. EMS consists of a monitor light, fault/action light, fault alarm and a monitoring panel with individual indicators for each machine system on the panel. This system should be tested as a part of the start-up procedure.

Warning categories

Level 1 – Operator awareness

This is when the LED alert indicator flashes, warning the operator that a problem exists that does not require immediate attention. Such a warning may be a low output from the alternator and if operating at night this may be more urgent as the lights will drain the battery. The warning lights associated with level 1 are outline above, (1).

Level 2 – Operator response

At this level of alarm the LED alert indicator and the action fault light will flash. At this stage the operator should change the method of operation. This may occur if the coolant or oil temperatures become too high. The operator may have to reduce load on the engine. The operator will then have to monitor the temperature gauges and if the temperature continues to rise, shutdown the machine.

Level 3 – Immediate shutdown

Once this point is reached the LED alert indicator and action fault light will be flashing, along with the EMS audible alarm sounding. This informs the operator that the machine should be stopped and shut down immediately until the problem is rectified. This warning is outlined above, (3).

Key start switch



OFF (1)

Insert key and turn the key from off position to on. Turn the key to the OFF position to stop the machine.



ON (2)

Turn the key clockwise to ON to activate all cab circuits.



START (3)

Turn the key clockwise to START to crank the engine. Release the key when the engine starts.



After 30 seconds of cranking if the engine does not start, return the start switch to OFF and wait for two minutes before attempting to START again.

Ground level engine shutdown switch

Most machines have a shutdown switch that is located at ground level.

To stop the engine, place the switch in the off position.

The engine will not start unless this switch is placed in the on position



Emergency stop button

In the event of an emergency, depress the emergency stop button inside the cab.
Don't use this button to shut down the machine unless there is an emergency.

Power mode switch

The excavator has three different modes of power. When the key start switch is turned on, the power setting that was put in place before the machine was shutdown will be activated. Select a suitable power mode for the type of working conditions and work being conducted.



Mode III

This mode is suitable for heavy duty work, which requires a high operating speed. This switch gives maximum power.



Mode II

This mode is suitable for ordinary work. This provides a medium power to the machine.



Mode I

This mode is suitable for light duty work only, such as levelling as it does not require high speed. This provides the minimum amount of power and reduces fuel consumption.

Engine throttle switch

Located in the cab of the excavator is an engine throttle switch. This can be used to set a certain engine speed. It has the following characters on its dial to indicate whether a fast or slow engine speed has been selected.



Decrease

Turn the dial towards the image of a turtle to decrease the engine speed.



Increase

Turn the dial towards the image of a rabbit to increase the engine speed.

Working switch

This switch is used for different working functions of the excavator.



Dumping

This position supplies additional power to the boom raise function and is required when loading trucks.



Side Wall Crowding

This position supplies additional power to the swinging action and is used when ditch work requires an accurate and neat finish.



Inching

This position allows the boom and stick to operate separately. It is used when precision levelling.

Swing lock pin

When this pin is engaged there will be no swing movement when transporting the excavator.

If the pin is not in place, the superstructure will be free to move and may cause damage to personnel or property.

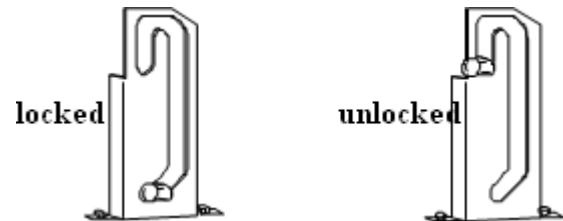

Hydraulic lock lever

When this lever is engaged all hydraulic functions will be locked. This should always be engaged prior to start up. To engage the lever place it in the lock position, pull the lever back.

In order to disengage the hydraulic lever so that operations may commence, push the lever forward into the unlocked position. This will make all hydraulic controls operable.



Steering controls

The final drive sprockets are located under the rear of the machine for normal steering. Always travel with the sprockets under the rear of the machine.

Move both travel levers / pedals in the same direction, either forwards or backwards, in order to move in a straight line.

When the travel levers / pedals are moved in the reverse direction, the machine travels towards the sprockets. When the travel levers / pedals are moved in the forwards direction, the machine travels towards the idlers.

Left travel lever / pedal operation

Reverse (1)

Move the travel lever / pedal backwards to operate the left track in reverse direction.

Stop (2)

Release the travel lever / pedal to stop the track and apply brakes.

Forward (3)

Move the travel lever / pedal forwards to operate the left track in a forward direction.

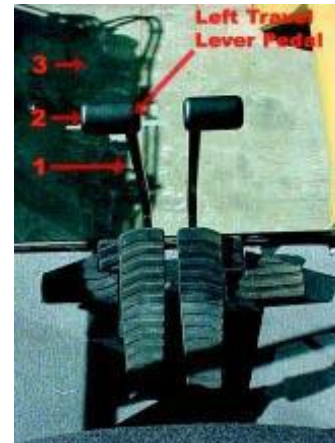

Right travel lever / pedal operation

The right travel lever / pedal operates in the same manner as the left travel lever / pedal. The only difference is that it operates the right track.

Spot left turn

Turn to the right and pivot on the left track.

Move the left travel lever / pedal backward and move the right travel lever / pedal forward at the same time. This allows a quick left turn in the anticlockwise direction.



Spot right turn

Move the right travel lever / pedal backward and move the left travel lever / pedal forward at the same time. This allows a quick right turn in the clockwise direction.

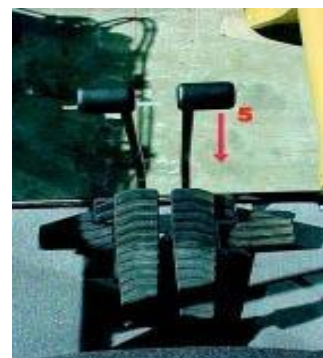

Pivot left turn

Move the right travel lever / pedal forward, allowing the machine to turn to the left and pivot on the left track.

Pivot right turn

Move the right travel lever / pedal forward, allowing the machine to turn to the right and pivot on the right track.

Operating Techniques

Videos to watch

Plant - Distracted-Drivers
Plant - Electrical Safety: Underground Contact
Plant - Excavation Death Trap
Plant - Excavations Introduction
Plant - Excavations Pre-Excavation Requirements
Plant - Excavations Situations
Plant - Excavations Sloping and Shoring
Plant - Excavations Sloping and Shoring - 2
Plant - Excavations Soil Instability
Plant - Excavations: Safe Work Practices
Plant - Excavator

Digging technique

When performing digging operation:

- Keep the machine level;
- Keep travel motors to the rear in order to protect them;
- Use controls in such a way that the attachment moves smoothly;
- Use the correct bucket digging angle;
- Never use the ditch wall to stop the swing of the attachment, doing so can cause damage to the hydraulics;
- Do not overload the bucket.

Position the stick at approximately 70° to the ground.

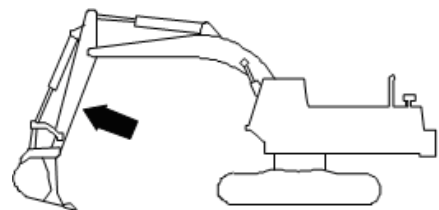

Manoeuvre the cutting edge of the bucket to 120°. This creates maximum break force.

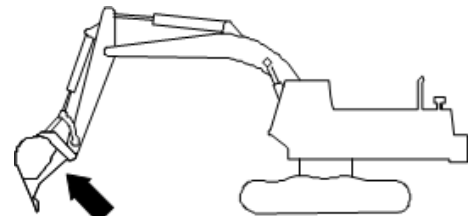

Move the stick in, towards the cab keeping the bucket parallel with the ground.

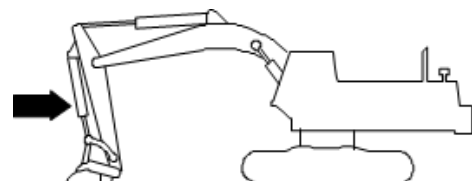

Is the stick stops travelling slowly raise the boom whilst closing the bucket at the same time?
Continue the pass with the bucket travelling horizontal, to peel the material into the bucket.

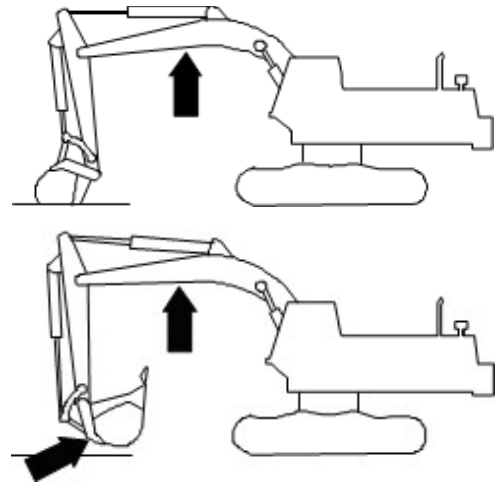

Close the bucket and raise the boom once the bucket is full.

Loading techniques

The four main loading techniques that will be used when operating an excavator are;

- Straight Loading;
- Tail Loading;
- Corner Loading;
- Top Loading.

The technique used is dependent upon the:

- Type of material being excavated and method of excavation;
- Floor conditions/spillage;
- Match of machinery being used;
- Wind direction; and
- Position of lighting plants.

Depending upon the material, digging conditions, the height and width of the bench, the excavator operator may choose to load with trucks parked along the bench. This requires a longer swing angle, approximately 20° on the arc.

When loading attempt to adopt the following techniques:

- Start swinging the load smoothly as the bucket is loaded and lifted;
- When practical tail load trucks as there is less lift height;
- Begin dumping the load when the Centre of the bucket is swinging over the side or end of the truck body;
- Begin the return swing before the bucket is empty;
- When the teeth clear the truck, body commence the lowering of the bucket to the next dig area. A good operator will always have the next dig site in mind;
- Position the stick and the bucket before landing;
- If the bucket stalls in the wrong position, lift the boom slightly or extend the stick.

Straight loading

Straight loading is when the excavator works parallel across the working bench. The haul trucks will approach the excavator in a clockwise direction, swinging straight out from the excavator and then reversing straight back lining up with the excavator cab.

Tail loading

Tail loading is where the excavator still works parallel across the working bench. The haul trucks will approach the excavator in a clockwise direction, swinging out at a 45° angle, then lining up with the excavator teeth and reversing back.

Corner loading

Corner Loading is where the excavator is finishing the current cut that it is working on. As the excavator reaches the end of the cut, it is required to take out the corner dirt that the machine is sitting on. At this point the truck will be placed in the corner, parallel with the face, as the excavator works around the corner. Once the corner dirt is removed, the excavator will resume digging parallel in the opposite direction and resume straight loading.

Top loading

Top loading is a method of loading where the haul truck and the excavator are on the same level.

Top loading is used when:

- Finishing the remains of a bench;
- Picking up batter trims;
- Starting a drop cut;
- Digging a sump.

Loading on a level surface

Ensuring that the excavator is on a level surface when loading trucks will:

- Maximize productivity;
- Reduce operator fatigue;
- Minimize machine wear;
- Assist with maintaining levels;
- Reduce instability of the machine.

Tramming

Tramming is the process by which the operator moves the excavator over a distance.

Prior to tramming the excavator, the operator must:

- Ensure that the excavator sprockets are positioned to the rear;
- Disengage the hydraulic safety lock;
- Select full throttle;
- Raise the bucket 500mm off the ground using the boom (or as per manufacturer's specifications);
- Bring the stick towards the excavator;
- Sound the horn twice and wait 5 seconds before tramming.
- Ensure that you tram for no more than 20 minutes at a time, after this allow the excavator to cool down.

Take this cooling down time to carry out the following inspection:

- Allow engine RPM's to run at high idle; Position hydraulic implements (bucket) on the ground;
- Place hydraulic safety lock into ON position;
- Inspect Excavator for oil, coolant and diesel leaks;
- Visually inspect rollers and idlers for damaged or missing components and excessive heat;
- Ensure the excavator is functional. If not, advise your supervisor Always take extreme care to protect the track adjustments when tramming off a bench.

Manoeuvring the excavator between the bench and pit floor

In order to manoeuvre an excavator from a bench to the pit floor and vice versa, the operator must:

- Create a ramp approximately 1.5 times the machine length from the bench to the pit floor;
- Ensure that the ramp has a gradient of approximately 45 degrees;
- Ensure ramp is safe and firm;
- Ensure the tracks have the correct tension. This is adjusted using a ram;
- Idlers must be to the front of the excavator;
- Allow track motors to support the weight of the excavator.

Tramming off the bench

- Climb down from benches by pushing the edge of the bench over and placing the boom on the floor of the dig.
- Walk the machine to the edge and start the decline from the bench keeping the tracks 90° to the bench.
- Keep weight on the boom and stick and decline slowly
- Lift the front of the excavator up slightly enough to clear the ground, off the front idlers when they reach the bottom of the ramp by bringing the stick forward.
- Keep walking out lifting the boom as you go for clearance.
- Climbing off the working bench complete.

Tramming on to the bench

- Approach at 90° to the bench and pull the top section down to lessen the angle of the climb.
- Place the bucket on the top of the bench.
- By pulling the stick in and tramming at the same time, the machine will climb up
- The ramp.
- When near the top of the bench, start raising the boom keeping it close to the ground.
- Once at the top of the climb push the bucket out to maintain balance.
- When tracks are level on top of the bench, the climb is complete.

Drop cuts

When starting a new bench a ramp is constructed from one level down to another. This is called a drop cut. A drop cut is usually constructed at the base of the main ramp to the pit, however for operating purposes it may be done in any part of the pit.

The drop cut should not be too steep and should be approximately 2.5 trucks wide. This should provide sufficient room for trucks to pass safely.

Position the excavator bucket over the area where the truck is to be parked. The truck operator will reverse the truck down the drop cut, underneath the bucket, keeping the truck square to the ramp.

Cutting batters

A batter is the name for the high wall of the pit.

When cutting batters the below procedure should be followed:

- Keep the bucket square to the face;
- Keep the bucket in line with the wall at the angle specified by site;
- Always face the boom towards the batter edge. This will enable a quick exit if the wall collapses;
- Ensure all trimmings are placed away from the wall to allow the dozer to clean up;
- If necessary, use incline meter or a spotter to get the correct angle.

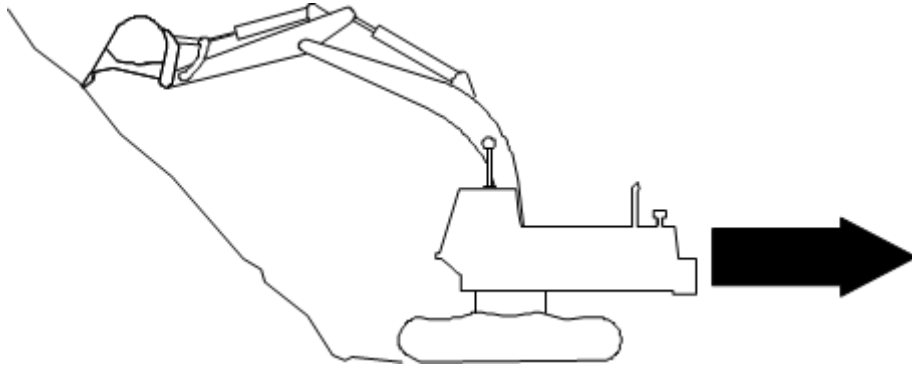

Excavator operators sometimes cut batters whilst mining, this is called cutting the batter on the run. For example, when the excavator operator finishes the cut, they then cut the wall to site specifications.

In order to cut batters on the run:

- Keep the tracks parallel to the high wall;
- Remove the bulk of dirt on the high wall;
- Trim the high wall according to the angle specified by site;
- Ensure that the truck is positioned parallel to the high wall.

Maximising productivity

The following contribute to the maximization of productivity:

- Truck cycle times;
- Clean haul roads and loading area;
- Good digging. The best digging force boom / stick configuration is a 15 degree either side from the right angle;
- Speedy excavator loading cycle times, working the hydraulics to their maximum;
- Filling the bucket to maximum capacity.

Slew brake

If there is a slew brake fitted to the excavator, then:

- Overusing the slew brake can result in it overheating;
- Engage the slew or park brake when leaving the machine unattended.

To prevent the engine or hydraulics overheating when digging in heavy material:

- Reduce material output;
- Stop digging for short periods to allow machine to cool down.

Operate EWP Guidelines

Video - [Plant - Safely loading and unloading EWP](#)

Video – [Using an EWP](#) Note: Skip Ads

Safe Operation of Plant

Refer to [Hazard Identification](#) for information on Safe operation

Refer to General Plant operations for Safety requirements for the operation of Plant

[Training information](#)

Pre-start checks **form sample** - [Plant pre-start](#)

What Is An Elevating Work Platform?

An elevating work platform (EWP) is either a telescoping device, hinged device, articulated device or any combination of these used to support a platform on which personnel, equipment or materials may be elevated to perform work. Types of EWP include scissor lifts, boom and knuckle boom lifts. EWPs are classified as:

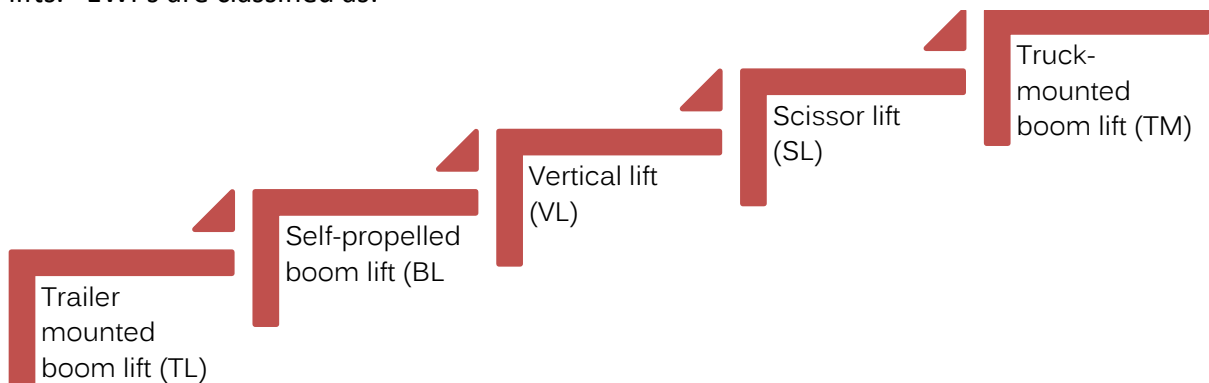



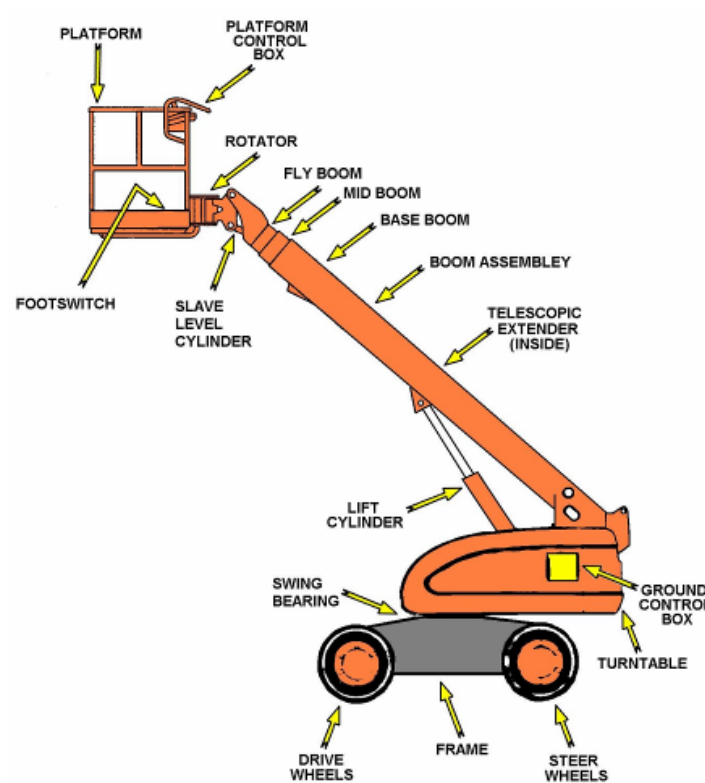





Components of a typical EWP with telescoping boom



(sourced from Workplace Health and Safety Queensland – Safe Operation of an Elevating Work Platform)

Hand And Audible Signals

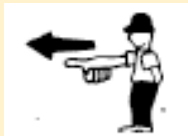
Whilst carrying out operations you may need to use hand and audible signals. Some common hand signals used on construction sites include:

Stop	Up	Lower	Luff down
			
Right	Left	Boom / Telescope in	Luff up
			

Whistles, bells or other devices may also be used as audible signals to assist with operations. Hand and audible signals are designed to make operations safer and more effective.

Every worksite should have a list or chart of the hand and audible signals that are commonly used on site. If you are unsure of the signals used on your site, speak with your supervisor or other team members for clarification.

Position Elevated Work Platform For Work Application

To position the Elevated Work Platform appropriately the following tasks should be carried out: *(Sourced from Workplace Health and Safety Queensland – Safe Operation of an Elevating Work Platform)*

Notify the relevant people (site foreman, safety officer etc.) of your arrival and intentions, discuss your work program with them and seek their advice.

Check the environmental conditions, including the wind speed, to ensure they are within the manufacturer's specifications (the wind speed capabilities can be located on the compliance plate).

Set the EWP up as close as possible to the work that you are required to do, in such a way that it will fully meet your requirements but at the same time create the least possible disturbance to others working close by. An observer may be needed to assist you in positioning the EWP. Make sure the EWP will not be on a slope that exceeds the manufacturer's recommendations.

Firmly apply the parking brake and place the transmission in neutral (or in accordance with the manufacturer's recommendations).

Place all the required traffic control displays and warning devices. Warning signs at the front and rear should be placed at least 50 metres, but not more than 150 metres, from the vehicle.

Ensure any necessary barricades or road marker cones are placed along the side of the vehicle. Road marker cones should be arranged to keep traffic clear of the area where the elbow of the boom will be operating.

Set the rotating flashing lights in motion.

If the EWP does not have outriggers / stabilisers, chock one pair of its wheels, by firmly placing suitable obstructions against each wheel to prevent the machine from moving in any direction.

If the EWP has outriggers, chock the front wheels and set the outriggers onto a firm surface or the appropriate packing. Make sure the area is clear of personnel before lowering the outriggers / stabilisers. The outriggers need to be fully extended, unless they are also being used to level the machine. Never reset the outriggers while the machine is elevated, because this can cause major instability and allow the machine to overturn. Remember to avoid soft ground, sloping surfaces or other conditions that may affect the stability of the unit.

If the EWP is being set up on a sloping surface, position the outriggers / stabilisers on the lower sloping side first, again making sure the area is clear of personnel before lowering the outriggers / stabilisers. This will allow you to level the platform and then engage the remaining stabilisers.

Check that all necessary safety harnesses and lanyards are on the machine and that they comply with the relevant standards and are in good working order. Re-check the anchor points for the lanyards, ensuring they are sound and not bent or broken. Check that the lanyards are the correct length for the anchor point(s) on the machine.

Check the personal protective equipment (PPE) needs for the job and make sure all the necessary PPE is available and in good condition.

Fully engage the EWPs spring lockouts, if these are provided.

Undo any basket and / or boom tie-down straps, to allow free movement of the basket.

Make sure all personnel are clear of the basket and boom while the basket is being lowered to the entry position.

Eliminate The Risk Of Tools, Equipment And Materials Falling

It is essential that whilst undertaking tasks with Elevated Work Platforms the placement of any tools, equipment and materials is carefully considered to ensure you are minimising or eliminating the risk of any of these items falling and causing injury to others. All tools, equipment and materials should be placed so they do not cause any trip hazards – if there is a chance someone may trip or kick the equipment then it should be restrained or placed elsewhere.

Fall Protection Requirements

Whilst using a Boom Type Elevated Work Platform a fall protection system needs to be implemented. When implementing the appropriate fall protection system the limitations of each component needs to be considered such as:

- Inertia reel types and limitations (suitable for restraint or arrest)
- Shock absorbing lanyards (static length for maneuverability within the platform, fully extended length)
- Harness type including stirrups or designed for suspension trauma mitigation
- Anchor point classification in different types of EWPs.

Operate Elevated Work Platform

When operating an EWP you should: *(sourced from Workplace Health and Safety Queensland – Safe operation of an Elevating Work Platform)*

Check the fit of your safety harness and the lanyard length is correct for the type of harness and attaching points. Clip the harness lanyard to the anchor point.

Check that small items such as nuts and bolts cannot get under the foot switch, as this would stop it operating

Look up and around - make sure there are no overhead obstructions or powerlines that might have been overlooked.

Moving the basket and / or boom during operation may introduce or create new hazards e.g. greater proximity to powerlines. The EWP must be monitored to ensure that its basket and boom are travelling in the direction intended.

Commence the elevation by shifting the control lever. Do not operate the lift at a high speed, especially if you are in a confined space.

Elevate the EWP to the full extension required, provided it is safe to do so.

Slew the boom, where fitted, to make sure that this function operates smoothly.

When you release a control lever there will be a delay of a few seconds before the

relevant function stops. This is called the 'ramp', and it allows the function to slow down to a stop rather than jerk to a halt.

Operating a scissor lift:

Never overload the Elevated Work Platform as overload protection may shut down the lift function and overloading could damage the hydraulics.

Make sure the machine is set up on a flat stable surface as protection systems may not allow the lift function to work when the machine is parked over certain grades.

Locate the machine as close as possible to the final position, raise the platform and slide out the extension to the work area.

Avoid moving the machine when at height.

Operating a trailer mounted EWP:

As trailer mounted Elevated Work Platform are utilised for tree lopping amongst other things, it is important to barricade the potential fall area and set the machine up so it is not hit by falling debris.

Lower the stabiliser legs and make sure the trailer is level before operations.

Maintain awareness of tree branches / other materials and how they will fall, do not fall anything onto the trailer body.

Some trailer mounted Elevated Work Platforms have an oscillation function that can be used to manoeuvre the platform around obstacles.

Operating a vertical type EWP:

These are designed to operate on flat surfaces and are usually electric powered and generally designed for one person only, always make sure the charging lead has been removed.

As these are used in and around indoor areas at height where people do not usually work, always be aware of the risks such as exposed electrical components / buzz bars. Operating techniques are similar to scissor lifts.

Operating a knuckle / boom EWP:

Set up the boom lift body on a firm stable surface, physically check the immediate area for dips, hollows or holes in the ground.

Always travel with the platform lowered and remain alert, always consider the length of the entire unit when manoeuvring.

Four units with four-wheel steer capability setting up the steer to right / left (all wheels work in conjunction with each other) this can be used to move the unit laterally.

Setting up the steer as "crab steering" gives very sharp left or right steering for tight areas.

The nature of the task also needs to be considered by asking questions such as:

- What is the possibility of gear dropping from the platform
- Barricading and signage requirements for different jobs
- Physical requirements of the task and how many people are required

- Tools and equipment requirements.
- Stability of the EWP at all times
- When and how to modify work methods
- Weather changes
- Are there electrical lines nearby?

Emergency Descent Devices (EDD)

The majority of EWP are now fitted with emergency descent devices to enable emergency evacuations from the bucket or work platform if necessary. Should a situation arise where there is failure of the controls whilst elevated you should firstly call out to a spotter to lower the basket / platform using the ground controls.

The following is a general procedure to be following in this instance (*sourced from Workplace Health and Safety Queensland – Safe Operation of an Elevating Work Platform*):

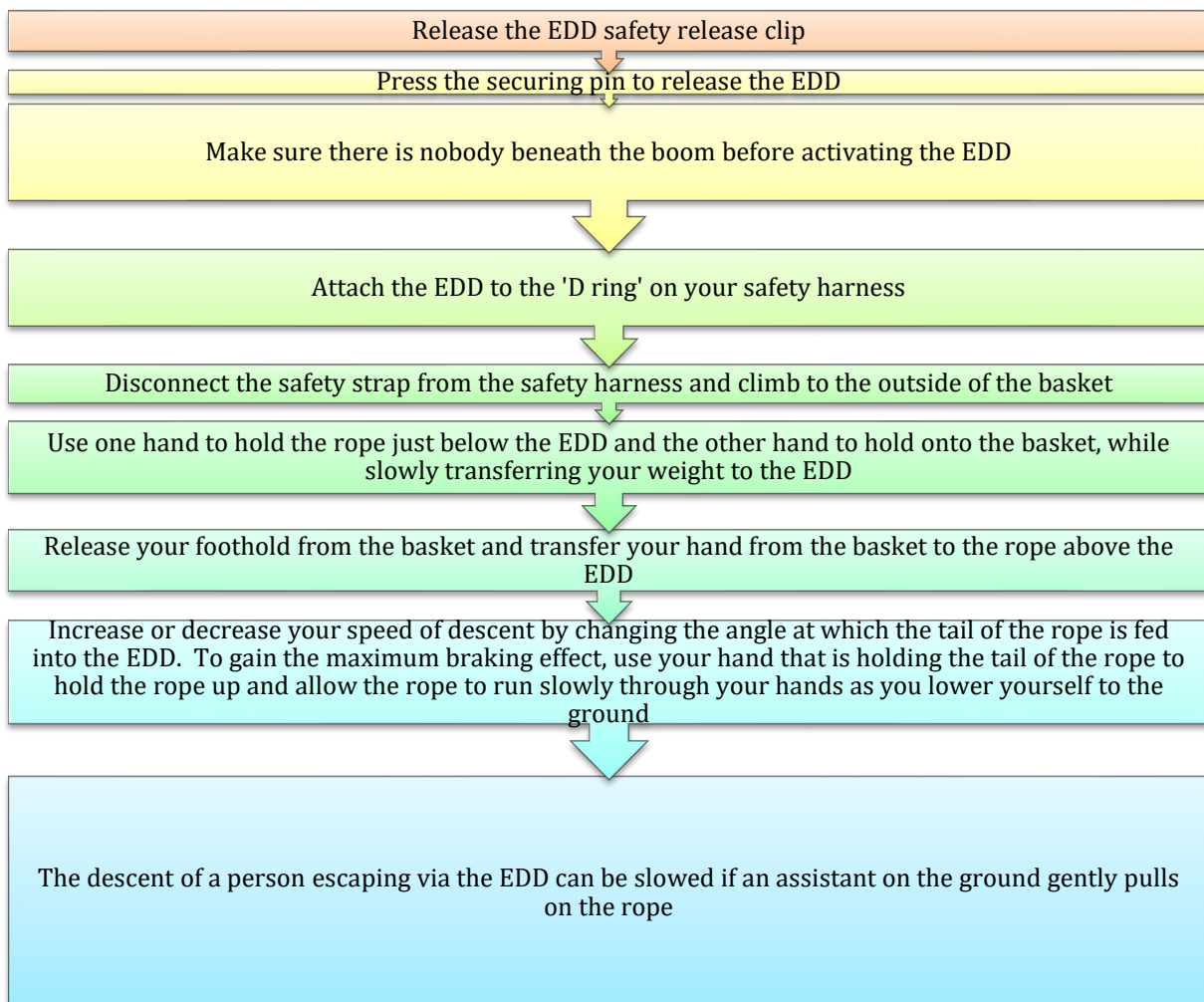

Lower Elevated Work Platform And Shut Down

Once all tasks have been completed using the Elevated Work Platform it needs to be lowered and the boom stowed. To do this you should:

- Check the area around and under the basket to ensure the area is clear of people, obstructions and any other hazards.
- If people are present within the area you should sound the horn to get their attention and indicate to them that you will be lowering the Elevated Work Platform.

- Lower the boom slowly and carefully into the cradle.
- Once the Elevated Work Platform is completely lowered, the machine should be driven to its designated safe parking area and turn everything off.
- Remove any tools and equipment that were stored on the Elevated Work Platform for the task and store appropriately according to site procedures.

Dismount the Elevated Work Platform and lock control panel doors.

Remove PPE such as harnesses and store appropriately according to site procedures.

Shut down the motor and isolate the fuel supply (if required).

Powerlines

Video - [Powerlines - Minimum safe distances](#)

Post-Operational Checks

A post-operational check needs to be completed each time you use an Elevated Work Platform. As with the pre-operational check you should always report any faults or damage to the Elevated Work Platform.

Mobile plant on suspended slabs

Instructions and advice from structural engineer regarding demolition techniques on suspended floors and load bearing capacities are followed.

A Structural engineer shall visit the site to determine the structural adequacy of the building. The engineer shall consider the load of the machine and all stockpiled materials then write a detailed plan in consultation with the PCBU, Plant operator site supervisor and other stakeholders.

Placement of mobile plant and allowable weight of demolition debris loads on suspended floors are confirmed according to advice of structural engineer.

Machines shall be operated and placed according to directions of the engineer. The supervisor shall ensure the instructions are followed.

Mechanical equipment and plant are positioned in operating locations and appropriate exclusion zone and traffic control are arranged.

Part of the risk assessment process shall include consideration of the placement of machine to ensure the safety of all and the correct use of the machine. It is critical that consideration be given to exclusion zones, signage, traffic control and spotters to ensure safety of workers and other persons.

Placement of mobile plant and allowable weight of demolition debris loads on suspended floors are monitored and controlled throughout the demolition process.

The supervisor shall monitor the placement of plant and debris on the suspended floor. Propping may be required in accordance with the DCP and SWMS which shall be determined in consultation with the structural engineer.

Mobile plant is moved safely between work locations, observing relevant codes and traffic management requirements.

When transporting plant from one part of the job to another we must ensure the safety of workers and others. A risk assessment shall be undertaken in consultation with stakeholders and a SWMS completed. The use of Traffic controllers, spotters, exclusion zones and signage may be required, or work may need to stop until the machine has passed.

Mobile plant is operated on suspended floors to demolish building elements or remove demolition debris using suitable attachments according to approved demolition plan, structural engineering advice, and current safe work method.

The operation of mobile plant on suspended slabs must be in accordance with the DCP, SWMS and the engineers report.

Pre-start checks **form sample** - [Plant pre-start](#)

Communication is maintained with team members, during the demolition process.

Clear communication must be maintained between the plant operator, spotters and the supervisor as appropriate. This communication can be by signalling where there is direct line of sight or by 2-way radio.

Regular programmed operator maintenance tasks are conducted according to manufacturer specifications and workplace requirements and log sheets are completed.

Programmed operator maintenance shall be carried out in accordance with the operator manual and recorded on the daily pre-start checklist. Any damage shall be reported to the supervisor.

Operate Demolition crushing plant

There are numerous types of crushing plant available

- Shears for cutting and breaking up demolition materials Insitu



- Stationary plant to crush and sort materials



Video - Video to watch – [Terex crushing plant](#)
Refer to manufacturer's operating instructions.

Operating technique is selected and modified to meet changing work conditions according to workplace and environmental requirements and manufacturer recommendations.

The Operator shall be familiar with the machines operations, select a technique as instructed in the SWMS and Operator shall ensure that the machine is operated in accordance with the Manufacturer's instructions. The supervisor shall verify

Pre-start checks **form sample** - [Plant pre-start](#)

Videos – Refer to Plant operations

Uncrushed materials are directed into hopper, and feed of uncrushed materials is maintained according to manufacturer instructions.

Raw materials shall be supplied into the machine's hopper by using load-shifting equipment. A continuous supply shall be maintained. If the machine is no longer required then it shall be shut down.

Operations are monitored, conducted and controlled within the equipment limitations and while communicating with relevant personnel, to maintain crushing and screening efficiency and effectiveness.

The operator shall ensure that the machine is attended and checked while in operation to ensure there is no failure, blockage or maintenance issue with the machine. The machine shall at all times be operated within its limitations. The Operator shall maintain communications with other plant operators and workers nearby to ensure maximum efficiency and safety.

Crushing plant is stopped, cleared of blocked materials and restarted as required, according to manufacturer instructions and site safety plan.

When a blockage occurs the Operator shall stop the machine, disengage energy sources and remove the blockage to the manufacturer's operating instructions. If the operator or another person is to enter the machine or put any part of their body within the machine, then the machine shall be turned off and the key removed

Crushing plant settings are maintained according to manufacturer instructions.

The Operator shall ensure that the machine settings are not altered from manufacturer's specifications. The supervisor shall verify

Operate mobile plant on suspended floors.

Placement of mobile plant and allowable weight of demolition debris loads on suspended floors are monitored and controlled throughout the demolition process.

Verify with the Engineer the allowable weight that can be stored on the slab during operation considering both the machine and the debris. The Supervisor shall verify.

Mobile plant is operated on suspended floors to demolish building elements or remove demolition debris using suitable attachments according to approved demolition plan, structural engineering advice, and current safe work method.

The Demolition works shall be in accordance with the Demolition Control Plan (DCP) or (SWMS). The DCP shall be written in consultation with the licence holder, supervisor, engineer. The plant shall be operated in accordance with Manufacturer's instructions. Attachments shall be selected that are appropriate for demolition work.

Power line distances

SA / TAS / NT / ACT (AS2550.1)

In South Australia, Tasmania, the ACT and the Northern Territory, equipment must not be closer than the following distances to power lines:

Power Line Type	Distance
Distribution lines up to and including 133kV (usually poles)	6.4m or 3.0m with a qualified 'spotter'
Transmission lines greater than 133kV (towers)	10m or 8m with a qualified 'spotter'

A 'spotter' is a competent person who watches and guides plant and equipment around power lines. Check with the relevant state/territory authority for specific spotter requirements.

VIC

In Victoria the Framework for Undertaking Work Near Overhead and Underground Assets states safe power line distances are as follows:

Power Line Type	Distance
Distribution lines up to and including 66kV (power poles)	6.4m or 3.0m with a qualified 'spotter'
Transmission lines greater than 66kV (towers)	10m or 8m with a qualified 'spotter'

NSW

In New South Wales, the relevant code is the Work Near Overhead Power Lines Code of Practice (section 3.3), which states:

Power Line Type	Distance
Up to 132kV	3.0m
132kV up to 330kV	6.0m
More than 330kV	8.0m

QLD

In Queensland the Electrical Safety Code of Practice (working near exposed live parts) must be followed and gives the following minimum distances as guidance:

Power Line Type	Distance
Up to 132kV	3.0m
132kV up to 330kV	6.0m
330kV to 500kV	8.0m

WA

In Western Australia rules relating to power line distances falls under Regulation 3.64 from the OSH Regulations and states the following as the minimum distances:

Power Line Type	Distance
Less than 33kV	3.0m
33kV to 330kV	6.0m

Videos -

<u>A Guide to Power Line Safety</u>
<u>A Guide to Power Line Safety - Intro</u>
<u>A Guide to Power Line Safety – How it affects the body</u>
<u>A Guide to Power Line Safety – Minimum safe distances</u>
<u>A Guide to Power Line Safety – Work near power lines</u>
<u>A Guide to Power Line Safety – Avoiding contact with underground services</u>
<u>A Guide to Power Line Safety – Contact with a power line</u>
<u>A Guide to Power Line Safety - Summary</u>
<u>Powerlines - Minimum safe distances</u>

Manage recyclables & waste

Videos – Refer to Plant operations

Organise materials and equipment for loading.

Refer to [Hazard Identification](#) for information on Safe operation

Work site procedures for segregating and locating recyclable and waste materials are confirmed with relevant personnel. The nominated supervisor for the works shall identify those materials to be segregated and provide instruction to the operator on where they shall be located pending removal from site. The area shall be isolated by barrier tape and signs. A risk assessment shall be undertaken to decide on the extent of control measures required.

Materials shall be segregated

According to material type, cleanliness or contamination and where appropriate discuss with the recycler their requirements for delivery, storing, palletising etc.

Recyclable materials to be loaded

Recyclable materials to be loaded are identified and checked to ensure integrity of on-site sorting, as required.

The nominated supervisor for the works shall identify those materials to be loaded and provide instruction to the operator as to how materials shall be sorted. It shall be considered whether the cost of recycling warrants the activity versus dumping costs. At all times the client instruction including tender conditions and legal requirements shall be met. Legal requirements may include “Heritage listing” of buildings. A risk assessment shall be undertaken to decide on the extent of control measures required. To facilitate recycling each area shall be signed to identify the type of materials stored

Waste materials to be loaded are identified and checked

Waste materials to be loaded are identified and checked to ensure integrity of containment, as required.

The nominated supervisor for the works shall identify those materials to be loaded and provide instruction to the operator to ensure materials remain within the designated area and are stacked to ensure the stored materials do not collapse. A risk assessment shall be undertaken to decide on the extent of control measures required

Load and move materials.

Pre-start checks **form sample** - [Plant pre-start](#)

Materials are loaded safely and efficiently according to type and using an approved loading method to maintain integrity.

A risk assessment shall be undertaken to decide on the extent of control measures required to determine how the materials can be loaded onto the lifting device. Pallets, bins, racks or tying of bundles shall be considered

Materials are moved safely and securely according to organisational requirements, manufacturer specifications, and requirements of relevant legislation and codes.

A risk assessment shall be undertaken to decide on the extent of control measures required, considering manufacturer's recommendations. Materials shall be secured where appropriate to ensure they do not fall off the conveyance

Unload and store materials.

Materials are unloaded safely and efficiently in designated area according to type and using an approved unloading method to maintain integrity.

A risk assessment shall be undertaken to decide on the extent of control measures required

Explosive Powered Tools (EPT)

Video – [Using an EPT](#)

Video – [Tools - Nail Gun Safety](#)

Video – [Tools - Handheld Power Tools](#)

Plan & prepare

Refer to [Hazard Identification](#) for information on Safe operation

Pre-start checks **form sample - [Tool pre-start](#)**

Explosive-actuated tools use an explosive cartridge or gas discharge to fire a fastener into hard materials such as concrete, mild steel, and masonry (Figure 40-1). Used improperly, explosive-actuated (or powder-actuated) tools pose obvious hazards. The tools should be treated with the same respect as a firearm. Most jurisdictions—including Ontario—require that operators be trained before using the tools and carry proof of training on the job.

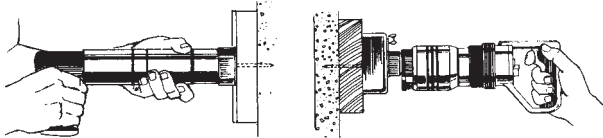

Figure 40-1: Explosive-Actuated Tools

Hazards

Flying Particles – This is the major hazard. On impact, materials may break up, blow apart, or spall off. This often happens when fasteners are fired too close to a corner of masonry or concrete or when they strike materials such as glazed tile, hollow tile, or thin marble tile.

Ricochets – These usually result when the tool is not held at right angles to the base material, or the fastener hits a particularly hard material such as stone or hardened steel. Always check the type of material to ensure that it can safely accept the fastening device.

Noise – Explosive-actuated tools create an extreme pulse of sound when fired. This can create a noise hazard. The new Noise regulation (381/16) requires employers to assess the risk to workers of noise exposure and provide adequate controls to protect them. Hearing protection devices such as earplugs or earmuffs may be used if no other controls are appropriate. Operators of the explosive-actuated tool must be protected from noise as well as other workers in the area—especially when the tool is operated in a confined space.

Sprains and Strains – These injuries usually result from using the tool repeatedly in awkward, cramped, or unbalanced positions. Operators should try to work from a balanced position on a solid surface.

Explosions – There is always the risk of explosion or fire when the tools are used in atmospheres contaminated by flammable vapour, mist, or dust. The work area must be ventilated—mechanically if necessary.

Blow-Through – When the base material does not offer enough resistance, the fastener may pass completely through and fly out the other side. This is particularly dangerous when fasteners penetrate walls, floors, or ceilings where others may be working. If necessary, keep areas behind, around, and under material clear of people. Fencing or barriers should be erected to prevent people from entering these areas.

Personal Protective Equipment

In addition to the standard personal protective equipment (PPE) required on construction projects (see the chapters on PPE in this manual), the operator of an explosive-actuated tool should wear hearing protection, eye protection, and a face shield. Heavy shirts and pants also provide some protection against ricochets and flying fragments of material and fasteners.

Tool Types

High-Velocity Tools – High-velocity explosive-actuated tools use the expanding gases from the exploding cartridge to propel the fastener. The gases push directly against the fastener. These tools are rarely used in construction, except in special cases to penetrate thick steel or very hard material—they are usually used in military, salvage, or underwater applications. No one should operate high-velocity tools without special training.

Low-Velocity Tools – Most explosive-actuated tools used in construction are low-velocity. The expanding gases from the exploding cartridge push against a piston, which in turn drives the fastener into the base material (Figure 40-2).

Figure 40-2: Low-Velocity Explosive-Actuated Tool



Many different low-velocity tools are available, from single-shot models to semi-automatic models using multiple cartridges in strip or disk holders. Some tools are specific to one size of fastener or type of cartridge. Most can be fitted with various pistons, base plates, spall stops, and protective shields for different jobs.

Tool Components

Pistons

Specialized pistons are available for different fasteners. Such pistons are designed for the fastener and should not be used with other types. Misusing a tool with a specialized piston can result in under- or over-driven fasteners or fasteners that leave the barrel misaligned, leading to ricochets. Some general-purpose tools can take various types of pistons.

Tool Power Controls

Some tools feature a “power control” device. This allows an operator to make a tool adjustment so that either all or only part of the available cartridge power is used. Power controls may ultimately let manufacturers market only one cartridge in each calibre. The goal would be to handle every application that the calibre is capable of

performing with one cartridge, power-controlled to the appropriate driving force needed.

Set-out fasteners

Fasteners used with explosive-actuated tools are made of special steel to penetrate materials without breaking or bending. Never use any kind of substitute for a properly manufactured fastener.

Generally pins and studs should not be used on hard, brittle, or glazed materials such as cast iron, marble, tiles, and most stone. The fastener will either fail to penetrate and ricochet or the base material will shatter.

Materials whose hardness or ductility is unknown should be tested first. Try to drive a pin into the material with a normal hammer. If the pinpoint is blunted or fails to penetrate at least 2 mm (1/16"), an explosive-actuated tool should not be used.

Fasteners are invariably fitted with a plastic guide device. Its purpose is twofold. When the fastener is inserted into the barrel, the guide keeps the fastener from dropping out. It also aligns the fastener inside the barrel so it will penetrate the base material at right angles.

There are two basic types of fasteners:

1. Pins
2. Studs

Pins – These are fasteners designed to attach one material to another, such as wood to concrete.

They resemble nails, but there the similarity stops. Ordinary nails cannot be used as fasteners in explosive-actuated tools.

Head diameters for pins are available between 7 mm (1/4") and 9 mm (3/8"). Lengths vary from 12 mm (1/2") to 76 mm (3"). Washers of various types and diameters are available for different applications.

Pins should be selected for appropriate length, head size, and application. As a general rule, pins need not be driven into concrete more than 25 mm (1"). Using a longer pin is generally unnecessary and also requires a stronger cartridge.

Follow the manufacturer's directions on length, penetration, and appropriate material (Figure 40-3). For example, one cut-nail fastener is available for fastening drywall to relatively soft base materials but is recommended for virtually no other application. Testing may be necessary on some masonry materials that vary widely in hardness and durability.



Figure 40-3: Types of Pins

Studs – These are fasteners consisting of a shank that is driven into the base material and an exposed portion to which a fitting or other object can be attached (Figure 40-4). The exposed portion may be threaded for attachments made with a nut.

Studs are also available in an eye-pin configuration for running wire through the eye.

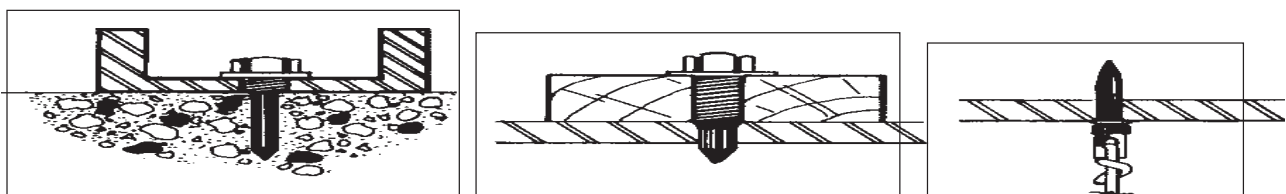

Figure 40-4: Types of Studs

Clip Assemblies – Fastening to the base material is done by a pin, but the pin is attached to a clip assembly configured to secure a uniquely shaped item (Figure 40-5). Clip assemblies are available, for instance, to hold conduit. One ceiling configuration comes with pre-tied 12-gauge wire.



Figure 40-5: Types of Clip Assemblies

Cartridges

Manufacturers recommend certain cartridges for certain applications. Because recommendations cannot cover every possibility, testing may be required with unfamiliar base materials.

Cartridges come in .22, .25, and .27-calibre sizes. Larger calibres hold more powder, which drives the fastener in further—or into harder base materials.

In addition, all three calibres are available with different levels of powder charge. For some tools, there may be as many as six different powder charges available. Some manufacturers produce tools that use a long-case version of the .22-calibre cartridge. It is critical that operators understand cartridge selection and cartridge identification systems (Table 40-1).

Table 40-1: Cartridge Identification System

COLOUR	NUMBER	CARTRIDGE POWER
Grey	1	Lowest
Brown	2	
Green	3	
Yellow	4	
Red	5	
Purple	6	Highest

Shots may be packaged or loaded as single cartridges, strips of ten in a plastic holder, or a round disk holding ten cartridges. The tool model will determine the calibre and how the tool is to be loaded.

Number identifications are printed on the outside of cartridge packages. Cartridge tips are colour-dipped for identification. Some strip cartridges are held in a plastic strip the same colour as the cartridge tips.

The general rule is to start with the weakest cartridge and increase one cartridge colour/load number at a time to reach the penetration required. Too strong a charge may cause shattering, ricochets, or blow-through. Too weak a cartridge will keep the fastener from seating itself properly.

Gas Canister

Some explosive-actuated models are powered by a replaceable fuel cell. The cell contains a mixture of gases typically composed of butane, propylene, propane, dimethyl ether, butylene, etc. Consult the manufacturer's Safety Data Sheet (SDS) for complete details about chemical composition.

When the nose of the tool is depressed, a specific amount of gas is released into a combustion chamber and ignited by a spark when the trigger is pressed. This action causes the piston to drive the fastener to a set depth.

Use EPT

Fastening Steel

Low-velocity explosive-actuated tools should not be used on hardened steels, tool steels, or spring steels. Where the grade of steel is unknown, test by trying to hammer the fastener in. If the pin is blunted, bent, or fails to enter at least 2 mm (1/16"), do not use a low-velocity explosive-actuated tool— it's not up to the job.

Don't try to fire a fastener any closer than 13 mm (1/2") to the free edge of steel. Keep in mind that this applies only to steel. When fastening steel to concrete, you must consider the allowable margin for concrete as well: 63 mm (2 1/2 ").

When fastening two pieces of thin sheet steel to a base material, hold the sheets together. Gaps caused by bending may lead to ricochets (Figure 40-6).



Figure 40-6: Ricochet

Special spall stops or protective shields are required for applications such as fastening Sheetmetal to masonry or Sheetmetal to structural steel. Consult the operating manual or the manufacturer to ensure that the right components are being used for the job.

Fastening Concrete and Masonry

Concrete and masonry materials are not always uniform in consistency or hardness. As a result, they may spall, chip, or cause a ricochet when the fastener strikes a spot or layer harder than the rest. Use the spall guard recommended by the manufacturer.

Once material is spalled or left with a ricochet hole, do not fire a second pin any closer than 50 mm (2") to the damaged area. The area may be weakened and spall further or cause a ricochet off its sloped edge (Figure 40-7).



Figure 40-7: Ricochet off a Sloped Edge

Pins tend to cause breaks near the edges of concrete and masonry. Don't drive pins closer than 63 mm (2 1/2 ") to a free edge (Figure 40-8).

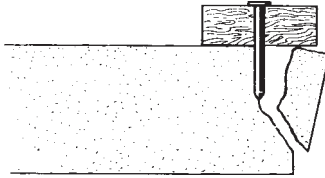

Figure 40-8: Pins Driven Close to the Edge Can Cause Breaks

Misfires

With misfired cartridges, follow the procedures stated in the operating manual for the tool you are using. Because of the wide variety of tools available, procedures for misfires may differ. When such information is not available, take the following steps.

- Continue to hold the tool against the base material for at least 30 seconds. This protects against a delayed discharge of the cartridge.
- Remove the cartridge from the tool. During removal, keep the tool pointed safely toward soft material such as wood. Never use any kind of prying device to extract the cartridge from the chamber. If the cartridge is wedged or stuck, tag the tool “DEFECTIVE and LOADED” and lock it in its storage container. Never try to dismantle a tool with a cartridge stuck or wedged in it. Again, tag

it “DEFECTIVE and LOADED,” lock it away, and call the manufacturer’s representative for help.

- Regulations require that a misfired cartridge be placed in a container of water.
- Keep the misfired cartridge separate from unused cartridges and return it to the manufacturer for disposal. Never throw misfired cartridges in the garbage.
- Be cautious. The problem may be a misfired cartridge, but the tool may also be defective. Check the tool for obvious damage, perform function tests, and use the tool only if it operates properly.

Secure & store EPT

- Workers who pick up an explosive-actuated tool must immediately prove to themselves that the tool is not loaded. This action must become instinctive and be carried out before anything else is done with the tool. Even after watching someone else handle the tool before passing it on, make sure that it’s not loaded.
- Explosive-actuated tools should be used, handled, and stored properly.
- Never put your hand or fingers over the end of the muzzle for any reason, even when the tools are not loaded with fasteners.
- Tools must be inspected and function-tested before work starts. Proper training and the operator’s manual will describe how to carry out both of these requirements.
- Operators must be trained on the explosive- actuated tools they are using and must wear all the required personal protective equipment.
- Firing explosive-actuated tools from ladders is not recommended. From a ladder, it can be difficult to press the tool muzzle against the base material with enough pressure to fire while maintaining three-point contact with the ladder. Consider using a platform ladder or scaffold.

For tasks overhead or at heights, work from a scaffold or another approved work platform to ensure solid, balanced footing. As an alternative, use a manufacturer’s pole accessory if the reach is normal ceiling height (8–10 feet). The pole secures the tool and permits firing by the operator standing below.

- Do not leave the tool unattended unless it’s locked in a box.
- Load the tool immediately before firing. Don’t walk around with the tool loaded.

- Do not use explosive-actuated tools in areas where there may be exposure to explosive vapours or gases.
- Fasteners should not be fired through pre-drilled holes for two reasons.
 1. Unless the fastener hits the hole accurately, it will probably shatter the edge.
 2. The fastener derives its holding power from compressing the material around it. A pre-drilled hole reduces this pressure and therefore the fastener's holding power. (This is why studs and pins driven into steel should penetrate completely through the metal. Otherwise the compressed steel trying to regain its original position can loosen the fastener by pushing against the point. With the tip completely through the metal the same pressure only works to squeeze the pin tighter.)

Maintain EPT

Tools in regular use should be cleaned daily. Tools used intermittently should be cleaned after firing. All parts of the tool exposed to detonation gases from the cartridge should be cleaned and lightly oiled according to the manufacturer's instructions. The cartridge magazine port, cartridge chamber, and piston sleeve should be wiped clean but never be oiled.

The tool brush supplied is adequate for most cleaning tasks. Stubborn carbon should be loosened with a manufacturer's spray detergent oil. Tools being checked for immediate use should be wiped dry of oil. Failure to clean the tool as recommended can lead to corrosion, pitting, fouling, and failure to work properly. Ideally, the tool should be cleaned before being returned to storage.

Tools with a power control adjustment will accumulate additional powder residue from firing—especially when the control is set to restrict the amount of cartridge strength being used. Semi-automatic tools may also accumulate powder residue. These tools need to be cleaned more often.

Sluggish performance may indicate that a tool needs cleaning. Tool action will slow to the point where a competent operator can detect the difference. Most manufacturers recommend major maintenance, inspection, and cleaning every six months. This involves stripping, inspecting, and cleaning parts not covered in daily maintenance.

Storage

Regulations require that both the tool and the cartridges be stored in a locked container with explosive loads of different strengths in separate containers. Cartridges should only be removed from the locked container when they are going to be used immediately.

Regulations

- Any worker using an explosive-actuated tool must be instructed in its safe and proper use.
- Before using the tool, the operator must check to ensure that it is in good working order. This means inspection and function testing.
- Tools firing fasteners at a velocity of more than 90 metres/second must have a protective guard at least 75 mm in diameter, mounted at right angles to the barrel of the tool and centered on the muzzle end of the tool, if practical.
- The tool must require two separate actions before it will fire:
 1. Pressure against the surface of the material
 2. Action of the trigger.
 - Explosive-actuated tools must be stored in a locked container when not in use or when left unattended.
 - The tool must not be loaded until ready for immediate use.
 - Whether loaded or unloaded, the tool must never be pointed at anyone.

- Cartridges must be marked or labelled for easy identification. Cartridges of different strengths must be stored in separate containers.
- Misfired cartridges must be placed in a container of water and be removed from the project.

Clean up

[Refer to housekeeping](#)

Lead Exposure

Refer to [Hazard Identification](#) for information on Safe operation

Video – [H&H - What is lead poisoning?](#) Skip the Ads

Video – [H&H - Toolbox - Infection Control](#)

Video – [H&H - Handwashing](#)

There is the potential for overexposure to lead when using explosive-actuated fastening tools in indoor applications with poor ventilation.

Hands and skin may also become contaminated by lead. This could lead to ingestion if skin is not covered and hands are not washed.

Controlling Lead Exposure

1. Consider alternative fastening methods such as gas-powered systems.
2. If you must use explosive-actuated tools, follow the Ministry of Labour's Guideline "Lead on Construction Projects". Some recommendations for the operator include:
 - The guideline recommends at least an N95 respirator. However, refer to the manufacturer's specifications to determine if the respirator can protect against lead.
 - Wear protective clothing such as gloves and coveralls.
 - Wash hands with soap and water before breaks, eating, drinking, or smoking, and do not chew gum.
 - NEVER TAKE CONTAMINATED WORK CLOTHES HOME.

If you suspect that you are suffering symptoms from lead exposure, see your family doctor and ask for a blood test to determine the presence of lead. Lead contamination in the human body can accumulate over time. It also takes the body time to expel this lead after exposure.

Cut and bend materials using oxy-LPG equipment

Plan and Prepare

Refer to [Hazard Identification](#) for information on Safe operation

Applications

Oxy cutting of mild steel remains as the most versatile, portable and economic process for general applications. Particular strengths of the process are its ability to cope with long cuts, thick materials, complex shapes, internal openings, bevelling, positional and locational applications.

Work instructions and operational details are obtained

Refer previous Units

Safety (OHS) requirements are followed

[Refer Hazard Identification](#)

Protective Clothing

You must protect yourself from the radiated heat and rays when welding with oxy/acetylene.

Wear:

- shade 5 or 6 goggles - Australian Standard approved;
- a shirt and trousers without cuffs of tough flame-resistant material (thick cotton or wool);
- firm fitting leather shoes or boots;
- leather gloves; and head covering.

Hazards

Note; Oxygen by itself is not flammable or explosive. However it will support combustion and cause material to burn freely.
--

Safety with oxygen

- Don't operate pneumatic tools with oxygen.
- Don't use it for spray painting.
- Don't use it instead of compressed air.
- Don't blow out pipelines, vessels or containers with oxygen.
- Don't use it to freshen the air, clean fumes in a confined space or cool yourself on a hot day.

Safety with acetylene

- Don't try to transfer acetylene from one cylinder to another.
- Acetylene is dissolved in liquid acetone in the cylinder.
- Always leave the cylinder key in the cylinder when using acetylene.
- The fusible plugs on these cylinders melt at 100°C. Store the cylinders upright in a cool, well ventilated protected location.

General Safety

- Oxy/acetylene welding is quite safe if you use the equipment properly and keep it in good working order.
- Make sure your work area is well ventilated.
- When you finish welding a job, mark the work HOT to warn people not to touch it.
- The burning temperature of the combined oxygen and acetylene gases is about 3100°C.
- Treat this flame with extreme caution.

- Report all faulty or damaged equipment to your supervisor.

Signage and barricade requirements are identified and implemented.

Refer [SWMS](#)

Plant, tools and equipment are selected

Refer [SWMS](#)

Materials quantity requirements are calculated

Refer supervisor

Materials appropriate to the work application

Refer [SWMS](#)

Environmental requirements are identified

Refer [Environmental protection](#) and Refer [SWMS](#)

Set up and Test Equipment

Pre-start checks **form sample** - [Tool pre-start](#)

Oxy/acetylene cutting is used to cut steel in all industries.

Off-site Building and Construction and On-Site

Construction could be used to cut projecting column cleats, reinforcement steel, cutting holes in plate, cutting up waste for salvage and many other uses.

Figure 2 shows an example of the standard equipment used for oxy/acetylene welding with the welding tip replaced by a blowpipe attachment and cutting tip.

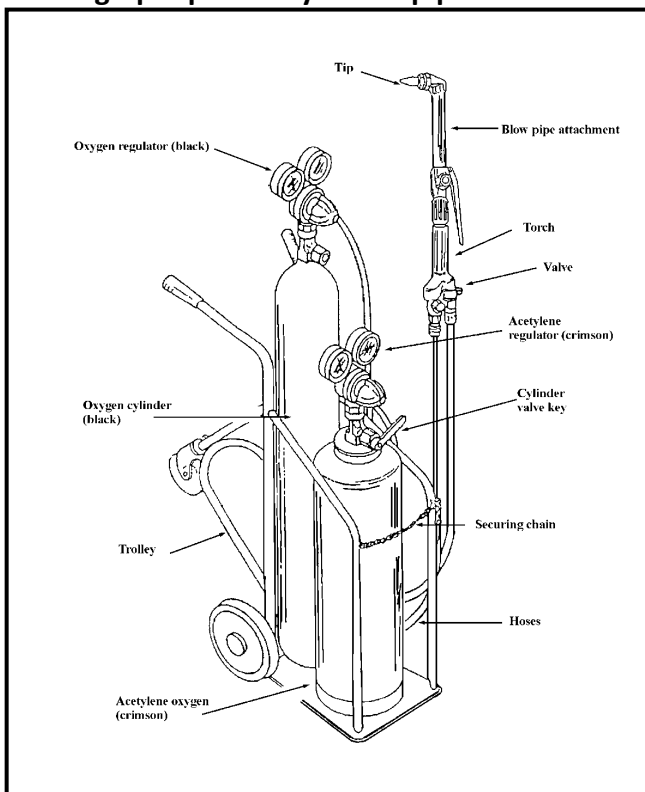

Figure 2: Oxy/acetylene Cutting Equipment

Videos

Tools – Oxy acetylene torch - cutting
Tools – Oxy acetylene torch - maintenance
Tools – Oxy acetylene torch – pressures
Tools – Oxy acetylene torch – straight cutting
Tools – Oxy acetylene torch - piercing
Tools – Oxy acetylene torch - torch
Tools – Oxy acetylene torch - welding

Correct fire extinguisher is selected

- Select a fire extinguisher by referring to the chart for selection of fire extinguishers or reading the label on the extinguishers
- Regulators are attached to oxy and acetylene bottles
- Ensure the regulators are securely fixed to the bottles, use the supplied spanner to tighten the regulator, do not use grease or other materials to form a seal in the case of damaged rubber seals.

Regulators are attached to oxy and acetylene bottles

For reasons of economy and efficiency the gas supply, often becomes more complex in larger workshops. Low pressure acetylene generator systems are possible, but not common. Large volume supplies of acetylene gas are normally met by carefully designed manifold systems connecting several cylinders together in "banks". Dual banks of cylinders are set - up to provide for continuity of supply when bank of cylinders is exhausted.

Continuity of supply is an advantage of the system, removing cylinder replacement from the tasks of the skilled tradesman. Piped supplies of gas around the workshop and supply points at planned locations provide ready access wherever gas is required and obviate delays arising from insufficient portable units.

Although acetylene gas provides a hotter flame than LP gas, and is necessary for gas fusion welding, LP gas is commonly used for piped workshop cutting applications where its efficiency is equivalent to acetylene. LP gas in liquid state can be bulk stored and distributed, which leads to economic use in workshops.

Oxygen gas, like LP gas, is capable of bulk distribution as a liquid. The system adopted depends on the workshop arrangement and the quantity used, which determines the relative costs. For moderate supplies the cylinder manifold system may be preferable.

Mechanical Oxy Cutting Equipment

Mechanical oxy - cutting equipment provides two basic functions. Long straight-line cutting operations involve extensive bench facilities and large areas of workshop. Cutting arms are equipped to carry multiple heads and are guided along straight and fixed tracks. Complex shapes are cut by profile machines tracing the shape of a pattern. Modern machines often combine both functions and are capable of multiple cuts whilst profiling. These machines are known as cross - traverse machines, straight line cuts are performed by locking the traverse action and allowing the machine to run on its track.

Diagram 90 - Inverse Acting Regulator

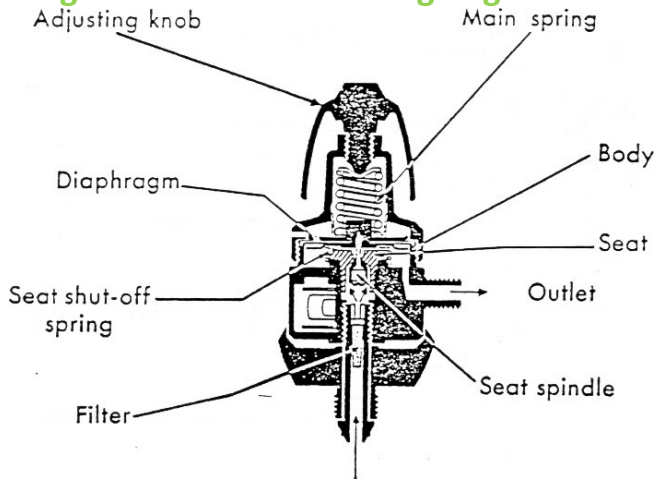

Lines are purged to manufacturer recommendations prior to lighting up.

Lines shall be purged according to the manufacturer's recommendations to ensure there is no foreign gas in the lines prior to igniting

Equipment is tested for leaks

Equipment shall be tested for leaks firstly by listening for leaks, if unsure use a soapy water solution to find leaks DO NOT EVER USE A NAKED FLAME TO FIND A LEAK

Correct pressures and cutting tips are selected

Cutting Torches

Two basic types provided for a combination cutting and welding torch, or for a cutting only torch. Selection depends almost entirely on the intended use, although for continuous and heavy cutting operations the heavy-duty cutting torch is recommended.

Diagram 91 - Heavy Duty Cutting Torch



Cutting Nozzle

Cutting nozzles are of two types, type 41 is connected into the torch by a special nut fitted up to the collar, whereas type 31 screws into an adaptor using the same torch. Alternatively the type 31 can be screwed directly into some torches without an adaptor, and obviously type 41 nozzles cannot be fitted to those torches. The figure 1 indicates that both nozzles are suited to acetylene gas. If the second figure was 4 the nozzles would then be used with LP gas.

Size 6, 8, 12 and 15 nozzles are normally used for cutting, recommendations to suit material thickness are shown in Table 27, under techniques. Nozzle type 31 requires a special tightening and removal sequence of operations, which must be carefully observed. Nozzle type 41 is recognised as being less prone to damage when not in use.

Diagram 92 - Types of Cutting Nozzles

20 annulus

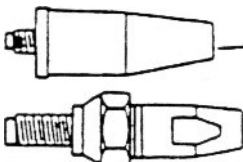

30 Screw-in

Cut Material

Video - <https://www.youtube.com/watch?v=8oYs2T6shZc>

Material is accurately marked and secured or clamped ready for cutting.

Generally the use of the oxy-acetylene torch is for quick demolition and cutting / removal of demolition materials. It should be considered whether the materials are to be salvaged or sent as scrap. If the materials are to be salvaged or reshaped for future use, then care should be taken to ensure the quality of the work.

Torch is lit correctly and safely according to manufacturer specifications.

Oxy-Cutting Techniques

Good oxy-cutting procedures can be summarised as follows:

Cutting flame must be correctly adjusted using the correct nozzle size and pressures to suit material thickness.

TABLE 27 Nozzle Selection Table

Thickness of Plate		Size of Nozzle	Oxygen Pressure	Acetylene Pressure
3 mm		8	100 kpa	100 kpa
6 mm	8	180	100	
12 mm		12	200	100
20 mm		12	235	100
25 mm		15	180	100
40 mm		15	300	100
50 mm		15	350	100

The cutting nozzle must be held squarely at the correct distance above the work. (2 mm - 3mm from work face to tip of pre-heat flames).

Material to be cut must be clean along the line of cut, and on both sides of the material. Cutting equipment must be in good condition and the nozzle kept clean, particularly the main oxygen orifice.

Travel speed must be carefully controlled to provide both a correct and constant speed. Cutting nozzle must travel as smoothly as possible. The difference between machine flame cut edges and hand flame cut edges can be mainly attributed to this factor, together with control of travel speed.

Setting of flame is adjusted for cutting to manufacturer recommendations.

Cutting Flames and Adjustment

Cutting nozzles reflect the two distinct parts of the oxy-cutting flame. Pre-heating metal to ignition temperature is achieved by several flames spaced around the central orifice which carries pure oxygen to the cut. Pre-heat flames are carefully adjusted to a neutral condition. The flow or pure oxygen is controlled according to metal thickness. The size of the central oxygen orifice and the oxygen gas pressure determine oxygen flow. Peripheral holes, through which oxygen/fuel gas mixture flows to form the pre-heat flames, are proportioned in size to the main oxygen orifice.

Diagram No 96 - Correctly Adjusted Flame

Nozzle

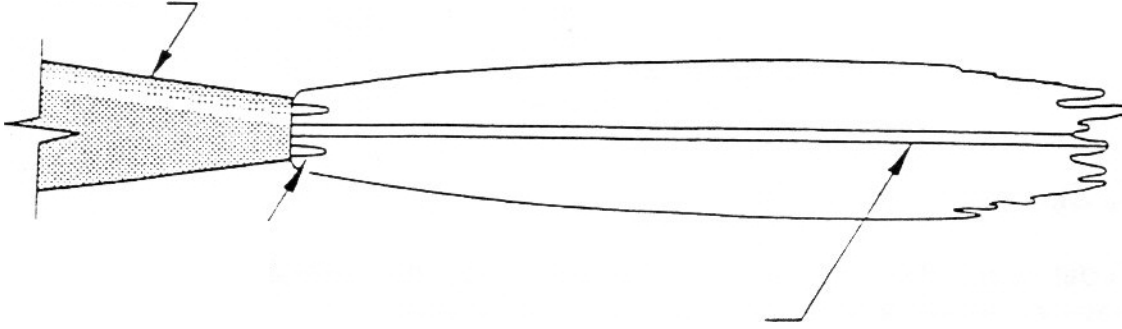

Neutral pre-heat

Cutting stream (approx. 150mm long)

Correct cutting position is adopted during cutting to set-out mark.

Quality of Oxy-Cut Edges

Oxy-cut edges should be square, or accurately bevelled, with sharp upper and lower corners and a smooth face, free from gouging. Slag adhesion should be slight or non-existent.

By attention to the quality of oxy-cut edges, and marking due allowance for kerf, components of very accurate size can be produced. There is seldom any need for further edge preparation in normal structural fabrication.

Diagram No 97 Features of a Good Oxy Cut

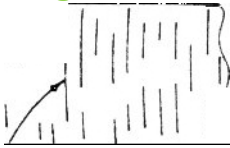

Light oxide film to face

Fine drag lines

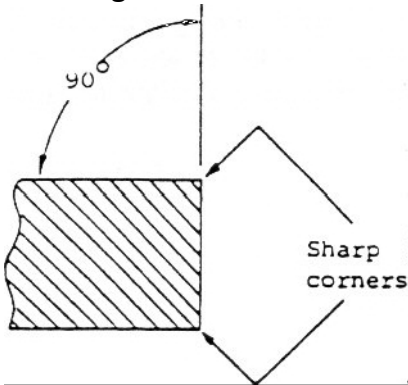

Heat and Bend Material

Material is accurately marked and securely clamped ready for cutting.

Measure twice cut once. Ensure materials are clamped or supported to ensure they do not fall and injure workers or damage property

Torch is lit correctly and safely according to manufacturer specifications.

Common Faults in Oxy Cutting

1. Excessive or Tenacious Slag

Excessive slag adhering to the lower edge of a cut may not affect the cut face at all, but its removal can be a nuisance. Slow travel speed is the most common cause, as can be easily demonstrated with a motorised cutting machine. Other factors producing more slag are dirty material and too.

Diagram 98 Excessive Slag Adhesion

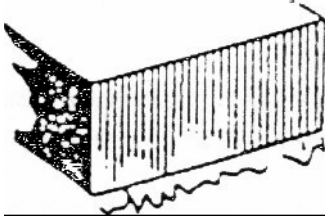

2. Top Edge of Plate Rounded

Excessive heat, along the top edge, causes rounding or "melt off" of the corner. Excess heat may result from a nozzle which is too large or is held too close to the work, incorrect adjustment of the flame, or travelling too slowly.

Diagram 99 Melting the Top Edge of the Plate

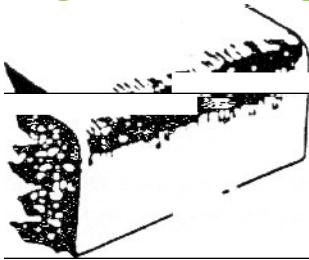

3. Gouging on the Cut Face

Gouging indicates too much oxygen, dirty material, travelling too slowly or erratic movement. All of these factors may be present to some extent, but the precise location of gouging will provide an indication of the most likely causes. Gouging along the bottom edge may be caused by scale underside the material, too high oxygen pressure, or too large a nozzle. Gouging over the entire thickness of plate may result from travelling too slowly or erratic travel speed and movement.

Diagram 100 Gouging of the Cut Face



4. Cut Face Tapered

Cut edges which are not square may result from tapering cuts, the kerf being wider or narrower at the top than bottom. Incorrect oxygen pressure is usually the cause of this problem. High cutting speeds and relatively low heat can also cause tapers at the bottom of the cut.

5. Undercut just below Top Edge

Turbulence in the gas flow may cause this problem; it is often the result of a high oxygen pressure or a faulty nozzle.

Diagram 102 Undercut of Cut Face



Trouble Shooting

Faulty and dirty cutting nozzles as a cause of cutting problems are not mentioned in the list of common cutting faults. The reason for this omission is that faulty or dirty nozzles can cause any of the faults discussed, either singly or in various combinations, and they are undoubtedly the major and most frequent cause.

The following procedure should solve any cutting problem.

1. Check nozzle size
2. Check gas pressure
3. Clean nozzle
4. Re-light and adjust cutting flame, further cleaning of nozzle, or replacement of nozzle, may be necessary if correct flame adjustment cannot be obtained.
5. Check height of pre-heat flames above the work surface, adjusting equipment or guides if necessary.
6. Check materials for cleanliness along the line of cut.
7. Establish cut and adjust travel speed until slag is blown clear of kerf leaving a clean edge.

Maintain steady and constant travel speed.

Heat is applied and weakening effects of the heating process are minimised.

Process of Oxy-fuel Gas Cutting

The oxy-fuel gas cutting process depends on the chemical reaction of heated iron or steel coming in contact with pure oxygen. The reaction is called oxidisation.

The cutting process depends on:

- Heating the steel to its ignition temperature (815°C)
- Oxidization of the steel in the path of the oxygen jet
- Removal of the slag by pressure from the oxygen stream
- The continuous movement of the blowpipe.

The preheat flame only heats the surface of the metal to a few millimetres depth. The purpose of the preheat flame is to keep the surface of the metal at the required temperature (ignition point 815°C).

The remaining thickness of the metal is heated by the combustion (burning) of the metal and the oxygen. There isn't enough heat to keep the reaction going without the preheat flame because

the surrounding metal and the cutting oxygen has a chilling effect. Successful cutting by oxy-fuel gas flames depends on two conditions:

- the metal's ignition temperature must be below its melting temperature; and
- the oxide formed must melt at a lower temperature than the parent metal.

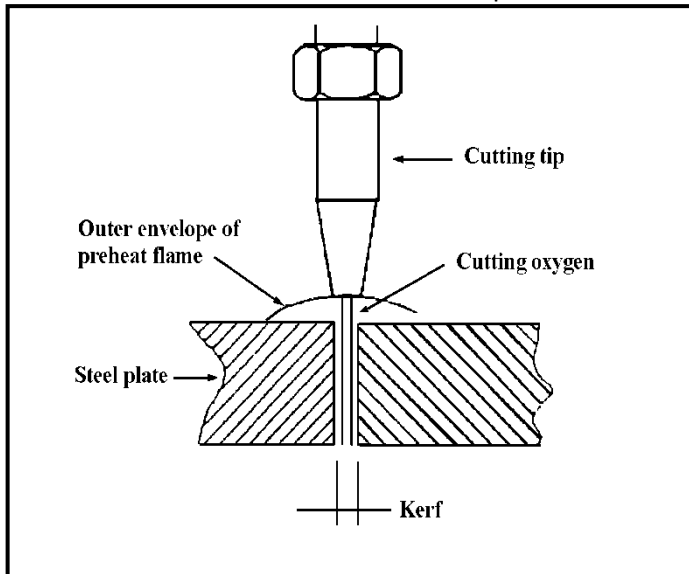

Figure 1: Oxy-Fuel Gas Cutting

Flame Cutting Theory and Practice

Thermal Cutting and Bending Processes

Thermal Cutting and gouging processes are discussed in terms of the process principles, equipment, techniques and applications. The main process discussed here are: Oxy - Fuel Gas Cutting

Oxy - Fuel Gas Cutting

The process of oxy - cutting depends upon the affinity that iron has for oxygen. Iron will readily combine with oxygen to form iron oxide and at a temperature of 815°C or over will do so very rapidly. In fact 815°C is the ignition temperature of iron and combustion will take place providing there is sufficient oxygen to support it. Further heat will then be generated by combustion, which is a chemical reaction, and it is important to note that combustion occurs well below the melting point of steel. Iron oxides have a melting point below that of steel.

Summary of Basic Oxy - Cutting Process

- The heating of the metal to its ignition temperature of 815°C.
- The burning or oxidation of the iron in the path of the oxygen jet.
- The removal of the molten oxides by the force of the oxygen stream.
- The continued and steady movement of the blowpipe along line of cut.
- Material is bent to specification and correctly cooled

Generally the use of the oxy-acetylene torch is for quick demolition and cutting / removal of demolition materials. It should be considered whether the materials are to be salvaged or sent as scrap. If the materials are to be salvaged or reshaped for future use, then care should be taken to ensure the quality of the work

Shut Down

Torch is switched off according to manufacturer specifications.

Turn off flame by firstly closing the oxygen valve on the torch then the acetylene.

Gas supply is shut off according to manufacturer specifications.

Next turn off the valves on the bottles then release the pressure in the lines. Never leave lines charged if you are leaving the work area or work is complete

Clean-up

[Refer to housekeeping](#)

Demolition

Refer to [Hazard ID](#) for Safe work practices

Deconstruction or Demolition, like other environmentally sustainable issues, is at present an interesting concept that fails to achieve widespread understanding or implementation.

Unlike standard construction practices, the Demolition industry must consider several factors specifically relating to safety and the environment as a primary consideration, not as a by-product of construction. It is one of those rare disciplines that actually create economic stimulation and growth by destroying assets in a socially responsible and professionally compliant manner.

Demolition is wide ranging in its scope and necessity for well-documented policies and procedures. Working as a supervisor in this industry is a challenging, broad and often stressful occupation. Ensuring that the proper policies and procedures are in place will mitigate stress and the likelihood of problems ballooning out of control.

Demolition Licencing

A licence to carry out demolition work is held by a business or undertaking carrying out certain demolition work. Work Health and Safety Regulation 2011 (WHS Regulation) s.144B.

An applicant for a licence to carry out demolition work must meet the requirements of this information paper and ss.144C and 144D of the WHS Regulation.

The holder of this licence must ensure that a nominated competent person (who meets the criteria set out below) is present or readily available to a worker carrying out demolition work.

To be a 'nominated competent person' an applicant must meet the following requirements:

- be at least 18 years of age
- have a working knowledge of the workplace health and safety management system held by the applicant

And have a working knowledge of:

- Work Health and Safety Act 2011 (WHS Act)
- Work Health and Safety Regulation 2011 (WHS Regulation)
- AS 2601 Demolition work (non-Queensland Government link)
- any relevant codes of practice applicable to demolition work

And

- have at least three years relevant industry experience
- have demonstrated practical supervisory experience in the demolition of buildings or structures, including having successfully completed at least three major projects involving demolition work

And hold a:

- Partial completion of Certificate III (CPC30413) and Certificate IV (CPC41013) in Demolition or an equivalent course issued by a Registered Training Organisation that covers competencies which meet requirements under the AS 2601 – 2001: The Demolition of Structures or
- [Relevant qualification](#) (e.g. a Degree in Construction Management or a Diploma or Associate Diploma in Building, this is acceptable in Queensland).

()

This skill set has been constructed in accordance with the requirements set down by Work Cover NSW and other jurisdictions for the role of licensed Demolition Supervisor. Work Cover NSW requires that the candidate must demonstrate competency in 11 units of competency; five certificate III qualifications and six certificate IV qualifications from CPC08 or an equivalent Training Package or accredited course. This course is designed to assist you in understanding the risks associated with your work and your obligations to comply with legislation in the execution of your duties as a competent demolition supervisor.

It is critical that you verify the qualification required in your state.

Demolish Small Buildings

Requirements of site demolition plan determined

The supervisor shall consult with Site Owner and Principal Contractor and other stakeholders to determine the scope of works, hazards on-site and how our works will affect other workers and members of the public who may be exposed to hazard and risk by our activities. The consultation outcomes shall provide a basis to write SWMS, WH&S Management Plans

Form sample – [Demolition Control Plan](#)

Site inspection is conducted

For your inspections and monitoring activities to be effective you will need a thorough knowledge of worksite procedures. These will include all relevant workplace operating procedures, work instructions and temporary instructions.

Form sample - [Site Hazard Inspection](#)

Form sample – [Contract establishment](#)

Form sample - [Daily pre-start](#)

Video - [Demo - Site-investigation](#)

Video - [Demo - Ruinous-building](#)

Video - [Demo - Power-lines](#)

All of these requirements are in place to ensure your worksite complies with the designated regulations and legislation.

It is important to make sure that the codes and standards you refer to are the most current versions as approved by state and federal government.

Purpose of Inspection

A work site inspection s required to identify the hazards associated with individual hot work tasks and to identify how those tasks can be managed.

Confirmation is obtained that relevant services have been disconnected

For your inspections and monitoring activities to be effective you will need a thorough knowledge of worksite procedures. These will include knowledge of services. It is wise to conduct an inspection with a person who has knowledge of the worksite and is aware of the location of services or has access to Building and service plans

[Form sample – Service isolation](#)

Video - [Electrical - Electrical safety](#)

Video - [Electrical - Stay safer up there, switch off down here](#)

Video - [Lockout](#)

All of these requirements are in place to ensure your worksite complies with the designated regulations and legislation.

Once identified all services shall be disconnected by an appropriately qualified person using Lock-out and tag-out procedures. Where a service must remain live all workers shall be advised and evidenced in the SWMS.

Requirements for safe work at heights

Refer to SOP - Safe Work at heights

Videos - Refer to Work at heights

Site is protected and secured to prevent unauthorised access

Ensure access to site is restricted to those performing the task

Building components are dismantled or demolished

Refer to SOP –

[Removal of fixtures](#)

[Removal of Glass](#)

[Removal of redundant pipework](#)

[Removal of redundant insulation](#)

Video - [Demo – Hot Work Hidden Hazards](#)

Video – [Demo - Dust-Control](#)

Video – [Demo - Bridge](#)

Video - [Demo - Old arts Council](#)

Small plant is operated according to manufacturer specifications

Site inspections will ensure that all activities are being completed to the required standards and in line with the specified procedures for the performance of tasks and the use of tools and equipment. It is essential that all tools and equipment are used in accordance with Manufacturer's recommendations including those recommendations for service and maintenance.

Any variation in conditions, situations, workers, processes, tools or equipment could impact on the validity of the work permit.

Videos - Refer to Plant operations

Communication is maintained with team members

A toolbox talk must be held regularly.

Work site conditions and progress are monitored in consultation with team

As the supervisor, it is your responsibility to conduct regular monitoring of tasks and activities to ensure that any changes in conditions are identified and responded to quickly.

SWMS to be reviewed

All subcontractors in consultation with principal contractor are to prepare Safe Work Method Statements in compliance with WH&S Legislation & principal contractor's Safety Management Plan prior to starting work at the workplace. If at any time a change in workplace conditions arise a review of that SWMS shall be considered by the supervisor

Sample form - [SWMS](#)

Sample form – [SWMS Review](#)

Removed components are relocated to storage or disposal area

Refer to SOP – [Demolition materials waste & recycling](#)

Materials and building component parts are safely handled

Refer to SOP – [Demolition materials waste & recycling](#)

Materials and components identified for salvaging are dealt with

The supervisor shall discuss with Stakeholders the ownership of salvaged materials. This information shall be disclosed to workers prior to commencement of work. When removed salvaged equipment shall be stored to prevent damage and made ready for transport as per instructions from Stakeholders

Work area is cleared, and materials disposed of

Everyone is responsible for his or her own personal rubbish, food scraps, drink containers, newspapers and the like, which also must be placed in the bins provided.

Plant, tools and equipment are cleaned, checked, maintained and stored

Ensure that all plant and equipment is maintained, cleaned and stored according to the manufacturer's guidelines and site requirements.

Asbestos Removal

Asbestos Types

Video - [ACM - Asbestos](#)

Video - [Asbestos - sampling lab](#)

Chrysotile

Chrysotile fibres appear to be transparent or whitish in colour. They will turn brown when exposed to heat. The body of the fibre has a herring-bone effect, while the ends of the fibres are similar to frayed rope.

Amosite

Amosite fibres are brown in colour and the body of the fibre has a smooth spear-like appearance, while the ends have a broken type similarity.

Crocidolite

Crocidolite, other than being bluish in colour, fibres are almost identical to amosite. Amosite and crocidolite fibres commonly occur together in natural form. It is the presence of these two fibres that warrant the main concerns.

Uses And Applications

Due to its accessibility, excellent structural qualities and resistant factors, it was one of the most widely used minerals. Asbestos was spun, woven into fabrics, curtains, compressed into blocks, hot pads, tiles, brake linings, filters and various insulation, construction and household products.

Video - [ACM - Uses and applications of asbestos](#)

Video - [ACM - history](#)

Video - [ACM - Asbestos in Construction: Workers](#)

Video - [ACM - Asbestos in Construction](#)

Video - [ACM - Asbestos where is it?](#)

Health Hazards

The health hazard resulting from asbestos comes from the ability of the substance to form a dust and the dust formed consists of minute fibres whose shape is hooked.

The damage results in disease, there are two diseases recognised as being caused by asbestos:

Asbestosis

Asbestosis occurs when the lung has reacted to a lot of asbestos over time and trying to protect itself forms scar tissue on the lining of the lung, (in the same way as if you have a burn, it forms a scar). As the area of scar tissue grows, the ability of the lining of the lung to exchange gases and therefore the ability to breathe is impaired. This is the same mechanism of disease as silicosis in quarry workers, or siderosis in welders and pneumoconiosis in mine workers.

Video - [ACM - Asbestos health issues](#)

Video - [ACM - Dear Dad - asbestos awareness](#)

Mesothelioma

Mesothelioma is a cancer that occurs in the lining of the lung. Where the lung tissue has reacted to the prolonged presence of foreign matter, it may start to grow malignant tissue which, when it has its origin in the lining of the lung, is known as mesothelioma

Personal Protective Equipment

Video – [Asbestos - PPE](#)

Face Mask

This type of protection should never be used in asbestos removal due to its “loose fit” and filtering limitations. Asbestos fibres can easily be inhaled through and beneath the sealing edge of the mask.

Video - [Asbestos - 3M Fit Test Kit](#)

Video – [ACM - Select & use PPE for Class B](#)

Video - [ACM - Select & use RPE for A Class work](#)

Respirator Maintenance and Protection

Respirators are only useful when there is a combined knowledge of purpose, maintenance, fitting, testing and their relationship to various fibre concentrations.

If the user is not clean shaven, wearing a respirator will provide little or no protection due to the air movement around and under the sealing surface of the mask.

Video - [ACM - Maintain P3 Mask](#)

CHECKING PROCEDURES

Inhalation Valves

These valves are located on the sides of the face mask and consist of a light rubber material. These diaphragm valves are held in place over their openings by small plastic studs. Check to see if they are in good condition and operate freely.

Exhalation Valve

This valve is located in the bottom of the face mask. Remove the exhalation valve protector and check the valve for wear, deterioration, distortion and for particles that could restrict the operation of the valve. This can be done by gently rotating the valve with your fingers.

This valve should be checked every time you put on your respirator. Your health and safety depend on this valve working correctly. If the valve sticks open all your air will come through the opening instead of through the filters and you might as well not even have the respirator on.

Filter Holders

The two large discs on the side of the face mask are called the filter holders. Inside the filter holders there is a rubber gasket that must be laying perfectly flat around the inside edge of the holder. Check to see that this gasket is not crimped or damaged and that it is seated correctly to ensure a good seal with the filter cartridge.

Face Mask and Straps

Check around the sealing area of the mask for cuts, cracks or excessive wear that could possibly prevent a good seal. Check straps accordingly to ensure they are in good shape.

Fit Testing of Respirators

After checking the respirator's parts, sealing edges and straps, a fit test must be performed to ensure maximum protection is provided to the user.

Protective Clothing

Asbestos does not enter the body through the skin and has no harmful effect on the skin. Thus, removal of asbestos itself does not call for the wearing of any special skin covering, although any asbestos deposited on the skin and in the hair must be scrubbed off before leaving the decontamination area.

The selection of protective clothing is therefore determined not by asbestos exposure but by climate, degree of physical exertion required, the other hazards involved in the work, and ease of decontamination.

Closely woven, disposable or washable coveralls without pockets or cuffs, but including an integral head covering, in combination with disposable overshoes, greatly assist in personal decontamination; however, these synthetic garments may make a substantial contribution to the heat stress of the individual in some environments. Trousers and coverall cuffs should be worn outside of boots and gloves. Where specific decontamination facilities are not available, the use of disposable coveralls is recommended.

Laundering Of Protective Clothing

All clothing worn in an asbestos removal area shall be regarded as potentially contaminated with asbestos.

As such, it is important that care is taken to ensure that the contractor, or other persons handling the clothing, fully understand the precautions necessary for handling asbestos-contaminated clothing. It is generally considered preferable that, where possible, all laundering be done on-site or in a facility provided and operated by the asbestos removalist.

The laundering of protective or work clothing in a worker's home shall be strictly prohibited. Approved launderers only must be used.

Removal of Asbestos

Before work can commence an Asbestos Removal Control Plan (ARCP) must be written and discussed with all stakeholders **Form sample - [ARCP](#)**

[Refer to Hazard ID](#)

Signs And Barriers

The work area should be defined by barriers and appropriately placed signs.

"ASBESTOS WORK AREA - NO UNAUTHORISED ENTRY".

Equipment For Asbestos Removal

Cutting Tools

Breaking through the finishing compound and cutting the reinforcing wire in the lagging are operations which can liberate considerable quantities of dust. Care should therefore be taken in the selection of tools and in keeping the dust levels in the removal area to a minimum.

The use of any power tools in asbestos removal requires caution since not all types are suitable, particularly in regard to internal dust collection and electrical safety in wet conditions. In general, compressed air driven power tools are preferable. Where doubt exists, reference should be made to the State regulatory authority.

Spray Equipment

Surface soaking from a spray jet is useful for small areas and where a total saturation is not practicable. The spray could be from an adjustable, pistol-grip, garden hose spray, fed from a mains supply or, where no supply

is readily available, from a portable pressurised vessel, such as a pump-up garden sprayer. A constant water pressure is desirable.

Total Saturation

Total saturation equipment is useful for large areas of insulation where time can be allowed for the water to soak in. The equipment consists of an injection head with its own shut-off control. These heads have numerous side holes through which water is fed into the insulation. The water flow is stopped during transfer of the head from one position to the next.

Setting up the removal area

It is critical that we contain any asbestos dust. To achieve this we must create an enclosure using 200 micron (same as used for concrete underlay). Ensure all joins are overlapped 30 mm and the join taped to ENSURE it stays sealed. We must also create a decontamination area where all tools and people are decontaminated

Video – [Create an enclosure](#)

Video – [Temporary wall](#)

Video - [Asbestos - Construct-decon-unit](#)

Video - [Asbestos - check enclosure.](#)

Video - [Asbestos - check the work area is safe](#)

Video - [Asbestos - Attach Plastic to Negative pressure unit.](#)

Video – [Asbestos - Attach plastic to decontamination unit.](#)

Removal Techniques

The removal techniques of asbestos-based materials from buildings and other structures shall be carried out by methods which will minimise the release of asbestos dust into the atmosphere, both during and after the removal operation. The choice of method is determined by the nature of the asbestos material, the quantity of insulant and its location.

Video – [A SWMS must be written](#)

Spray Method

This method shall be used only where relatively small quantities of asbestos-based materials are to be removed and where the following conditions apply to the material:

- The asbestos-based material is not covered with other materials such as calico or metal cladding which require prior removal;
- There is no reinforcing wire or other similar restrictions to removal;
- The asbestos-based material is not coated with paint or mastic;
- Where rapid temperature drop due to excessive water could cause damage to heated metal components;
- Where no live electrical conductors are present and where no damage to electrical equipment can arise from the ingress of water.

The spray shall be applied in such a manner as to ensure that the entire surface of asbestos-based materials is wet, but minimal run-off occurs. It is desirable for the asbestos-based material to be wetted through its full depth and maintained in a wet condition. It is recommended that a manually controlled, consistent low pressure, coarse spray such as from an adjustable, pistol-grip garden hose be used for this purpose.

It is important that the spray should be copious, but not such that the water droplets generate dust from impact with the surface of the insulation. When using cutting equipment to remove asbestos, the water spray should be directed at the site of the cut and the wetted material removed as the cut progresses.

The wetted asbestos-based material should be removed in sections and immediately placed in suitably labelled containers and properly sealed. Any small sections which may be dislodged should be collected and properly disposed of.

Removal of Asbestos Cement Products

The contractor should carry out this removal wet (using fine water spray of PVA) unless not practicable, for example, where an electrical hazard may be created.

Video - [Asbestos - ACM Sheet removal.](#)

Air locks should be placed on entrance doors to the work area comprising at least three sheets of plastic. In addition, a protective layer of plastic woven poly vinyl (200-micron minimum thickness) should be taped over any carpeted areas within the work area.

- Sheeting should be thoroughly wetted down with a fine spray of water before commencing removal. Nails should be cut with a cold chisel under the edge of the sheet or cut around the head using a punch, causing minimum damage to the sheet. If necessary, nails are to be punched through the sheeting to facilitate effective removal.
- Nails should be removed from the timber framework following this procedure, using pliers/nippers or similar device. Small sections of contaminated timber around the nail should be chiseled out and disposed of as asbestos waste.
- No power tools or oxyacetylene cutting equipment should be used unless permission to do so is granted by the superintendent following discussion with the supervising hygienist.
- Sheets should be removed with minimal breakage. Unnecessary smashing of asbestos cement sheeting shall not be permitted.
- Once removed, the back of the sheet should be wetted using fine water spray.
- The external surface should be wet wiped to remove any adhering dust before the bags are removed from the work area.

Cleaning Up of Asbestos Cement Debris

- The contractor should carry out this work wet except where not practicable.
- Thoroughly wet the debris with fine water spray.
- Shovel into asbestos waste bag. Small amounts of debris may be placed into bag, gloves being worn.
- If debris is present in topsoil, remove upper layer of topsoil, such that negligible asbestos remains and dispose of this material with the asbestos cement debris.
- All visible debris should be removed from the contaminated area such as that any risk of fibre inhalation has been effectively eliminated.

Video - [Asbestos - clean ac from ground.](#)

Waste Removal

Asbestos waste should not be allowed to accumulate excessively within the work area but should be bagged or placed in appropriate receptacles as the work proceeds.

Controlled wetting of waste should be employed, to reduce asbestos dust emission during bag sealing or in case of subsequent rupture of the bag.

Video - [Asbestos - Bagging of Waste.](#)

Solid asbestos waste should be collected in heavy duty 200 micron (minimum thickness) clear polythene bags of a maximum size 1200 millimetres in length by 900 millimetres in width. The bags should be labelled with an appropriate warning statement to the effect that the bag contains asbestos and dust creation and inhalation should be avoided.

- Asbestos waste bags should not be filled more than half full, in order to minimize the risk of bag tearing/splitting and also to assist in manual handling of the bags. The Manual Handling Regulations and Code of Practice should be consulted on this regard.
- Bags which have contained asbestos material should not be reused.
- Bags marked for asbestos waste should not be used for any other purpose.
- Bags should be twisted tightly, folded over and the neck secured in the folded position with adhesive packaging tape or any other effective method. The external surface should be cleaned to remove any adhering dust before bags are removed from the working area. All asbestos insulation should be double bagged outside the enclosure immediately following the decontamination process.
- Hard and sharp asbestos waste will require preliminary sealing or protective covering prior to placement in asbestos waste bags, in order to minimize the risk of bag damage.

The bags, once removed from the work area should be either:

- Placed in a solid (appropriately lined) waste bin or skip which should be secured at the completion of each day's work;
- Removed from site by an approved E.P.A. licensed carrier. Asbestos waste should not be stored on site.
- Routes of removal from the work area to the waste skip should be designated prior to the commencement of each removal contract. In occupied buildings, movement of bags from the work area to the waste skip should be performed out of normal working hours. The means of movement of waste bags through the building should be made at the discretion of the superintendent following discussions with the contractor.

Video - [Asbestos - Clean work area.](#)

The removal of waste bags from the work area through the decontamination unit should involve a "production line" operation as detailed below:

- One worker is to be located in each section of the decontamination unit.
- Waste bags are to be passed from cubicle to cubicle and "showered out" to remove any asbestos residue.
- Once removed from the decontamination unit the waste bags are to be double bagged prior to disposal.

Air Monitoring

A comprehensive air monitoring program will be required for all Friable asbestos removal projects.

Video - [Asbestos - AIR-monitoring.](#)

Cleaning And Dismantling Of Asbestos Removal Area

Video - [Asbestos – decontamination](#)

Video - [Asbestos - Pack away the vacuum.](#)

Video - [Asbestos - Personal decontamination B class work](#)

Video - [Asbestos - Exit-decon.](#)

Video - [Asbestos - Safe cleanup of storm damaged materials that may contain asbestos](#)

Video - [Why decontaminate](#)

Visual Inspections and Air Sampling

All surfaces from which asbestos-containing materials have been removed are to be examined for the presence of residue. Where the asbestos-containing material has similar appearance to the substrate, even gross removal cannot be satisfactorily determined at a distance of more than a meter. A strong narrow beamed torch should also be used to assist in detection of dust / debris.

Inspections for Completeness of Removal

The Hygienist should enter all spaces where asbestos removal has been performed in order to inspect the work at close range. If any asbestos containing debris is found, it shall be noted and reported without interrupting the inspection. The debris so identified should be removed before subsequent clearance inspection is undertaken.

Dismantling Of Removal Area

On completion of the asbestos removal job, all tools and equipment not used for cleaning should be removed from the removal area so that efficient vacuuming of the inside of the removal area can be carried out. Appropriate decontamination procedures must be observed. By spraying the internal surfaces of the plastic containment around the removal area with polyvinyl acetate (PVA) or similar water-based paint, any asbestos adhering by electrostatic attraction is effectively encapsulated.

Clearance To Reoccupy

When a satisfactory airborne fibre level has been achieved, protective screening may be removed by the contractor to enable a final clean-up of the area. It must be noted that any protective barrier between the work area and public area should remain intact until completion of all work.

Transport And Disposal Of Asbestos Waste

Asbestos waste transported to a disposal site must be packaged in the following manner:

The wrapped material may be transported in a roll on roll off skip. The skip must be lined with one layer of 200-micron plastic before loading to assist the packaged asbestos to safely slide to the designated area at the disposal point. If a roll off bin is not used, the asbestos must be double wrapped and taped as before. If unloaded manually or by mechanical means, e.g. crane, truck, etc., it must be placed into the excavation in a manner that does not allow damage or puncturing of the plastic.

Unloading the Tip Site

The transporter should carefully reverse into position at the designated disposal point, lower the skip and carefully tilt the skip to allow the asbestos to fall into the excavation, care should be taken to ensure that no damage or puncturing of the plastic occurs.

The driver should ensure that all necessary documentation is in order before leaving the disposal site. All contamination waste is to be transported in EPA licensed vehicles only.

Other tasks with asbestos

Video - [Asbestos - Change bag on vacuum](#)

Video - [Cleaning gutters](#)

Video - [ACM - cleanup of storm damaged materials](#)

Video - [ACM - Working safely for a renovator](#)

Video - [ACM - Zipwall](#)

Video - [ACM - painting ac](#)

Appendix - Documents available

Procedures

- Asbestos - Demolition work involving asbestos.pdf
- Asbestos - Exposure to airborne asbestos.pdf
- Asbestos - Limit on use of certain equipment.pdf
- Asbestos - Prohibition on use of asbestos.pdf
- Asbestos - Removal requiring Class A licence.pdf
- Asbestos - Removal work.pdf
- Asbestos - Waste Transport.pdf
- Confined spaces - Confined spaces.pdf
- Construction - Duties of worker-PPE.pdf
- Construction - Electrical construction installations.pdf
- Construction - Electrical safety.pdf
- Construction - General Construction Induction.pdf
- Construction - High risk work licensing.pdf
- Construction - Land clearing.pdf
- Construction - Land.pdf
- Construction - Lasers.pdf
- Construction - Management of risk to health _ safety - Construction work.pdf
- Construction - Pressure equipment.pdf
- Construction - Protect amenity of nearby neighbours.pdf
- Construction - Provision for traffic.pdf
- Construction - Resource storage and retrieval.pdf
- Construction - Traffic management.pdf
- Construction - WHS Management plan.pdf
- Demolition - Demolition work licensed.pdf
- Emergency management - Duty to provide first aid.pdf
- Emergency management - Evacuation coordination.pdf
- Emergency management - Evacuation practice.pdf
- Emergency management - Fire _ evacuation plan.pdf
- Emergency management - Fire evacuation instructions.pdf
- Emergency management - Potential emergency situations identified.pdf
- Emergency management - Testing of emergency preparedness.pdf
- Environmental Management - Air pollution by sandblasting.pdf
- Environmental Management - Liquid waste construction pump out.pdf
- Environmental Management - Odour.pdf
- Environmental Management - Particles and dust.pdf
- Environmental Management - Pest control.pdf
- Environmental Management - Scheduled wastes.pdf
- Environmental Management - Solid waste.pdf
- Environmental Management - Surface water construction site run off.pdf
- Environmental Management - Surface water exposed aggregate.pdf
- Environmental Management - Surface water quality.pdf
- Environmental Management - Surface water.pdf
- Environmental Management - Vehicle wash down.pdf
- Environmental Management - Wastewater reuse.pdf
- Heights - Fall Prevention.pdf
- Heights - Management of risk of falling objects.pdf
- Heights - Management of risk of falls.pdf
- Heights - Scaffolds.pdf
- Human Resources - Discrimination _ harrassment.pdf
- Human Resources - Enterprise bargaining.pdf
- Human Resources - Equal pay for equal work.pdf
- Human Resources - Exit Interview.pdf
- Human Resources - Life work balance.pdf
- Human Resources - Performance Appraisal.pdf
- Human Resources - Performance Development.pdf
- Human Resources - Professional Development.pdf
- Human Resources - Staff Complaints and Appeals.pdf
- Human Resources - Staff Discipline and Dismissal.pdf
- Human Resources - Staff Recruitment _ Selection.pdf
- Human Resources - Workplace Harassment.pdf
- Monitoring _ measurement - Audit.pdf
- Monitoring _ measurement - Calibration of safety measuring equipment.pdf
- Monitoring _ measurement - Eliminate the cause of nonconformities.pdf
- Monitoring _ measurement - Evaluate and select suppliers.pdf
- Monitoring _ measurement - Improvement.pdf
- Monitoring _ measurement - Investigation of incidents.pdf
- Monitoring _ measurement - Non-conformance.pdf
- Monitoring _ measurement - Review of systems.pdf

Monitoring _ measurement - Safety performance.pdf
Monitoring _ measurement - Statutory reporting requirements.pdf
Monitoring _ measurement - Timely reporting of information.pdf
Monitoring _ measurement - Verification.pdf
Plant _ equipment - Duties for PCBU managing plant.pdf
Plant _ equipment - Excavation work.pdf
Plant _ equipment - Groundwater.pdf
Plant _ equipment - Management and control of plant.pdf
Plant _ equipment - Mobile plant and equipment.pdf
Plant _ equipment - Off road and ATV.pdf
Plant _ equipment - Plant Design.pdf
Plant _ equipment - Powered mobile plant - general control of risk.pdf
Plant _ equipment - Services underground.pdf
Process _ Implementation - Authorised by management.pdf
Process _ elimination - Duty to prepare, maintain and implement.pdf
Process _ implementation - Compliance.pdf
Process _ implementation - Consultation.pdf
Process _ implementation - Development of an IMS.pdf
Process _ implementation - Document systems.pdf
Process _ implementation - Documentation of systems.pdf
Process _ implementation - Duties of other persons.pdf
Process _ implementation - Duties of workers.pdf
Process _ implementation - Duty holders.pdf
Process _ implementation - Duty in relation to general workplace safety.pdf
Process _ implementation - Duty of officers.pdf
Process _ implementation - Duty to prepare, maintain and implement.pdf
Process _ implementation - Establish measurable targets and objectives.pdf
Process _ implementation - Implementation.pdf
Process _ implementation - Primary duty of care.pdf
Process _ implementation - Procedures are established.pdf
Process _ implementation - Provide resources.pdf
Process _ implementation - Provision to workers of PPE.pdf
Providing a safe environment - Compressed air or liquid gas.pdf
Providing a safe environment - Hazard identification process.pdf

Providing a safe environment - Hazard identification processes are established.pdf
Providing a safe environment - Hazardous chemical.pdf
Providing a safe environment - Health monitoring - Hazardous chemicals.pdf
Providing a safe environment - Health monitoring - Lead.pdf
Providing a safe environment - Inductions.pdf
Providing a safe environment - Lead Paint.pdf
Providing a safe environment - Lone worker.pdf
Providing a safe environment - Managing risk - Air-borne contaminants.pdf
Providing a safe environment - Managing risk - Hazardous Chemicals.pdf
Providing a safe environment - Managing risk - Hazardous manual tasks.pdf
Providing a safe environment - Managing risk - PCBU to manage risks of hazardous chemicals.pdf
Providing a safe environment - Managing risk - falling objects.pdf
Providing a safe environment - Managing risk - health and safety.pdf
Providing a safe environment - Managing risk - hearing loss from noise.pdf
Providing a safe environment - Safe work method statement.pdf
Quality Management - Care of client product.pdf
Quality Management - Contract.pdf
Quality Management - Design and development changes.pdf
Quality Management - Manage design.pdf
Quality Management - Non-conforming product identified.pdf
Quality Management - Outputs of design and development.pdf
Quality Management - Plan and control design.pdf
Quality Management - Product conformity.pdf
Quality Management - Product meets specification.pdf
Quality Management - Product realisation.pdf
Quality Management - Product tracking.pdf
Quality Management - Production and service provision.pdf
Quality Management - QA Analysis.pdf
Quality Management - Quality system requirements.pdf
Record _ document control - Control of documentation.pdf
Record _ document control - Records.pdf
Record _ document control - Retention of documentation.pdf
Responsibility _ authority - Appointment of CEO.pdf
Responsibility _ authority - Appointment of CFO.pdf

Responsibility _ authority - Appointment of HR Manager.pdf
Responsibility _ authority - Appointment of HSR.pdf
Responsibility _ authority - Appointment of IMS Manager.pdf
Responsibility _ authority - Appointment of Project Manager.pdf
Responsibility _ authority - Appointment of Supervisor.pdf
Responsibility _ authority - Appointment of admin manager.pdf
Responsibility _ authority - Appointment of rehabilitation co-ordinator.pdf
Responsibility _ authority - Appointment of safety co-ordinator.pdf
Responsibility _ authority - Appointment of safety committee.pdf
Responsibility _ authority - Continuity of engagement of worker.pdf
Responsibility _ authority - Election of HSR.pdf
Responsibility _ authority - HSR to inspect the workplace.pdf
Responsibility _ authority - Issue of Provisional Improvement Notices (PIN).pdf
Responsibility _ authority - Training for HSR.pdf
Responsibility _ authority - Workgroups.pdf
Roads - Insitu stabilised pavements using cement.pdf
Roads - Insitu stabilised pavements using foamed bitumen.pdf
Roads - Insitu stabilised subgrades using quicklime or hydrated lime.pdf
Roads - Plant mixed stabilised pavements using cement.pdf
Roads - Polymer modified binder.pdf
Roads - Road furniture.pdf
Roads - Specifications ROADS.pdf
Roads - Stabilising disturbed land areas.pdf
Roads - Supply and erection of bridge barrier.pdf
Roads - Unbound pavements.pdf
Training - Provide appropriate training.pdf
Training - Provision of training, information.pdf
Training - Skills aquisitions.pdf
Process _ implementation - Establish and implement procedures.pdf
Providing a safe environment - Managing risk - Crystalline silica and silicosis.pdf

Safe Operating procedures

Asbestos (Friable) removal SOP.pdf
Asbestos (Non-friable) removal SOP.pdf
Construction - Carry LPG in Vehicles SOP.pdf

Construction - Ceiling Tiles Access SOP.pdf
Construction - Chemical Storage SOP.pdf
Construction - Confined Space SOP.pdf
Construction - ELCB - RCD SOP.pdf
Construction - Electrical Safety SOP.pdf
Construction - Erecting Temporary Fencing SOP .pdf
Construction - Generators SOP.pdf
Construction - Manual Handling SOP.pdf
Construction - Test and Tag SOP.pdf
Construction - Trade work On Ground SOP .pdf
Construction - Trade work Overhead SOP.pdf
Construction - Trench - Less Than 1.5m Deep SOP.pdf
Construction - Trench - More Than 1.5m Deep SOP.pdf
Construction - Using a Hazardous Substance SOP.pdf
Construction - Work on Roads SOP.pdf
Demolition - Removal of Fixtures SOP.pdf
Demolition - Removal of Glass SOP.pdf
Demolition - Removal of Redundant Ductwork SOP.pdf
Demolition - Removal of Redundant Insulation SOP.pdf
Demolition - Waste - Recycling SOP.pdf
EMP - Accidental Spills Cleanup SOP.pdf
EMP - Accidents and Incident Reporting SOP.pdf
EMP - Confined Space Rescue SOP.pdf
EMP - Fire - evacuation SOP.pdf
EMP - Rescue SOP.pdf
EMP - Sharps SOP.pdf
Heights - Dismantle Suspended Formwork SOP .pdf
Heights - Erect scaffold SOP.pdf
Heights - Ladders SOP.pdf
Heights - Mobile scaffold SOP.pdf
Heights - Travel fall arrest systems SOP.pdf
Heights - Trestles - Planks SOP.pdf
Heights - Work at heights on Roofs SOP.pdf
PPE - SOP.pdf

Plant - Concrete Cutting SOP.pdf
Plant - Detailed excavation SOP.pdf
Plant - Excavation near Utilities SOP.pdf
Plant - Floor Grinder Sander SOP.pdf
Plant - Lifting equipment SOP.pdf
Plant - Load onto a truck SOP.pdf
Plant - Refuelling SOP.pdf
Plant - Truck Operation SOP.pdf
Plant - Use SOP.pdf
Plant - Vicinity of Overhead Lines SOP.pdf
Tools - Air - Hydraulic SOP.pdf
Tools - Electric hand tools SOP.pdf
Tools - Explosive powered tool (EPT) SOP.pdf
Tools - Hand SOP.pdf
Tools - Lasers SOP.pdf
Tools - Petrol LPG SOP.pdf
Tools - Workshop SOP.pdf
Construction - Lead Paint.pdf
Disturbing or Removing Silica.pdf
Construction - Lead .pdf

Forms

EMP - Fire & Evacuation Observer Checklist.pdf
EMP - Incident investigation.pdf
INSPECTION - Construction.pdf
INSPECTION - Daily Prestart.pdf
INSPECTION - Demolition Asbestos - End of Day.pdf
INSPECTION - End of Day.pdf
INSPECTION - First Aid Kits.pdf
INSPECTION - Plant Pre-start.pdf
INSPECTION - Plant Truck.pdf
INSPECTION - Tool Prestart.pdf
INSPECTION - Transport Checklist.pdf
QA - Client Satisfaction Survey.pdf

QA - Condition Report.pdf
QA - Contract Establishment.pdf
QA - ITP Final Inspection.pdf
QA - ITP Trade Work.pdf
QA - Request for Information, EOT, Variation.pdf
QA - Review SWMS.pdf
QA - Site Diary.pdf
QA - Supplier Evaluation.pdf
QA - Suppliers Information.pdf
REGISTER - Hazardous Chemicals.pdf
REGISTER - Key.pdf
REGISTER - Product Tracking & Certification.pdf
SMP - Permit to Work.pdf
SMP - Project Management Plan.pdf

QA - Plant Maintenance Repair.pdf
REGISTER - Logbook.pdf
SMP - SWMS ARCP.pdf
SMP - SWMS Demolition.pdf
SMP - SWMS.pdf
STAFF - Management Safety Review.pdf
STAFF - Meeting Record.pdf
STAFF - Operator Competency.pdf
STAFF - Performance Appraisal.pdf
STAFF - Site Induction.pdf
STAFF - Training Needs Analysis.pdf
TRAINING - Portfolio.pdf

Risk Assessment

Asbestos in the workplace RA.pdf
Asbestos removal.pdf

Compressed air RA .pdf
Confined spaces RA.pdf
Construction work RA.pdf
Damage to property RA.pdf
Demolition.pdf
Electrical - Generators RA.pdf
Electrical RA.pdf
Environment RA.pdf
Explosives RA.pdf
Extreme Temperatures RA.pdf
Fluids under pressure RA .pdf
Footpath closure RA.pdf
Hazardous chemicals - storage RA .pdf
Hazardous chemicals RA .pdf
Heat Stress RA.pdf
Heights - Ladders.pdf
Heights Edge protection Scaffold Static lines RA.pdf
Heights RA .pdf
Heights above ground but below 2.000m RA.pdf
Heights mobile scaffold - Trestles RA
Hot work.pdf
Infectious diseases RA.pdf
Lasers RA.pdf
Lone workers RA .pdf
Manual handling.pdf
Mould.pdf
Outdoors RA.pdf
Overhead services RA .pdf
Plant - Crane Operations RA .pdf
Plant - EWP RA .pdf
Plant - Lifting equipment RA .pdf
Plant - Scissor lift RA .pdf
Plant - equipment fixed in buildings RA.pdf
Plant RA .pdf

Plant attachments RA.pdf
Public areas RA.pdf
Radiation RA.pdf
Rail corridors RA.pdf
Recurring hazards RA.pdf
Restricted spaces RA.pdf
Roads.pdf
Silica Dust RA.pdf
Tools - Oxy acetylene.pdf
Tools RA .pdf
Transportation tasks.pdf
Trenching - excavation.pdf
Underground structures RA.pdf
Uneven ground.pdf
Utilities RA .pdf
Wet weather RA.pdf
Wildlife in the work area RA.pdf
Work beside Roads RA.pdf
Work over water RA .pdf
Workshop or Factory.pdf
NHVR - Combined Risk Assessment .pdf

Training videos

Over 2,000 videos including those in this Manual.